



ETH zürich



Assessment of Recycled Phosphorus Fertilizers for Organic Farming: Chars, Ashes and Slags

The application of sewage sludge to agricultural land, a common practice to recycle nutrients in the past, is currently prohibited in organic farming due to the risk of soil contamination from pollutants. Incineration of dewatered sludge or disposal to landfill is costly and leads to greenhouse gas emissions as well as losses of nitrogen, sulfur and organic matter. Other options to treat dry organic matter are combustion and gasification. In the resulting ashes or chars, due to organic matter degradation, non-volatile elements including mineral nutrients like phosphorus, potassium, magnesium and calcium are enriched, yet there are also some potentially toxic elements left. The concentrations of nutrients and contaminants vary widely, dependent on the input material and the technologies applied. This fact sheet describes different combustion and gasification methods as well as several types of chars, ashes and slags with their characteristics and possible applications. Beyond that, it indicates various options to enhance the use of combustion products in organic agriculture.

Introduction

Thermal processing of organic wastes is a treatment option to reduce the volume of feedstocks, to obtain energy, and to produce useful by-products e.g. as soil amendments. Substrates which can be treated include sewage sludge, household wastes, food industry wastes (e.g. meat and bone meal), green wastes etc. Thermal treatment is well suited

for processing of feedstocks rich in lignin, such as woody materials. Incineration of the solid components obtained from meat and bone meal^[1] and sewages is an important method of disposal in the USA, the EU (e.g. in Germany, Switzerland) and Japan in order to reduce the waste volume^[2]. Dewatered and dried sewage sludge is burned

auto-thermally (meaning a self-sustained process) and can, depending on the water content, result in a net energy gain^[2]. Combustion of sewage sludge is primarily done in large-scale mono-incineration plants.

Since phosphorus (P) does not volatilize as easily as other nutrients it is concentrated in the remaining. In principle, no P volatilizes up to a gasification- or pyrolysis processing temperature of 900 °C and even at 1200 °C, a maximum of 10 % of total P is lost through volatilization^[3]. Nowadays, in countries of the EU additional reasons for incineration of sewage sludge and deposition of ashes are concerns about organic pollutants, pharmaceutical residues, pathogens and potentially toxic elements (PTEs: metals, metalloids and non-metals often referred as heavy metals) contained in raw sewage sludge^[4]. Meat and bone meal is often incinerated because sanitizing it for feed as a category 2 product implies high logistical costs, and hence incineration is the cheapest solution. Incineration of organic residues has some serious drawbacks with respect to maintenance of soil fertility and environmental quality, but also presents interesting options for the recycling of valuable elements, especially P.

Production of recycled P fertilizers from ashes or slags

Sources and available amounts

Feedstock for production of P fertilizers from ashes can be sewage sludge, wood, animal manure, meat and bone meal or other animal waste, or a combination of these different substrates. Currently 1.7 million Mg of mono-incinerated sewage sludge ash is produced annually worldwide^[2].

In Germany, about 500,000 Mg of sewage sludge on a dry matter (DM) basis is incinerated per year^[5] containing about 14,000 Mg P. Approximately 100,000 Mg ashes per year are available from combustion of firewood, containing approximately 2,000 kg P^[6]. In Switzerland, since the ban on sewage sludge use on agricultural land in 2006, 200,000 Mg DM of sewage sludge per year is either mono incinerated and deposited into landfills, co-incinerated in waste incineration plants or used in the cement industry^[7].

Thermal treatment technologies and related outputs for possible soil amendments

There are several available technologies for thermal treatment of organic residues (Figure 1):

Figure 1: Schematic overview of thermal processes to treat organic wastes

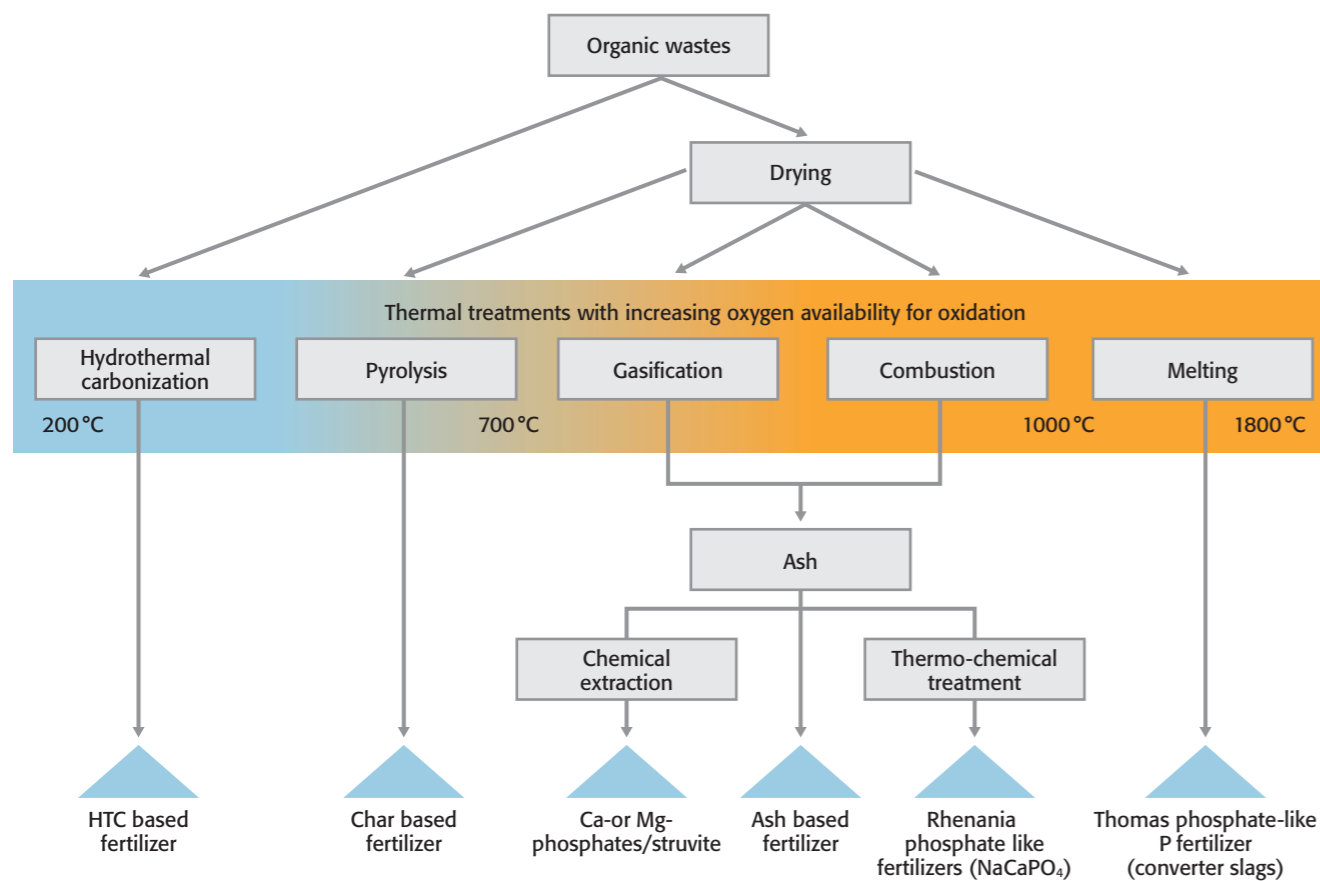

For treatment of organic wastes such as sewage sludge, meat and bone meal and organic household wastes different thermal processes are known, which all result in different end products.

a) *Hydrothermal carbonization*: Involves treatment in a closed system at moderate temperatures (180–250 °C) and a pressure of approximately 10 bar over an aqueous solution of biomass for several hours, resulting in the production of hydrochars (= HTC-chars) as residues. The produced char is a coal like material that can be used as energy source, for soil amelioration and as sorbent in water treatment processes. Different wastes have been used as feedstock, such as sewage sludge, urban organic waste and spent grains. The acidic environment during the production of hydrochars as a result of an increase of the oxonium ion concentration (H_3O^+) results in some P release into the liquid phase, or the P is adsorbed in the solid phase^[8].

b) *Pyrolysis*: Thermochemical decomposition of organic material by heating of solid (dried) biomass in an oxygen-deficit environment at moderate to high temperatures (200–700 °C) using long heating times. In general, pyrolysis of wastes produces gas and liquid products and a solid residue high in carbon content, char or bio-char^[9]. The main difference among pyrolysis and other processes like combustion and hydrolysis is: it usually does not involve reactions with other reagents like oxygen or water.

c) *Gasification*: A process that converts organic feedstocks into carbon monoxide, hydrogen and carbon dioxide. The material is treated at high temperatures (>700 °C), without combustion, with a controlled amount of oxygen and/or steam. The gas mixture is called synthetic gas (syngas), leading to the production of ashes.

d) *Combustion*: Combustion is a high-temperature exothermic redox chemical reaction in the presence of enough oxygen to allow the fuel to react completely to produce carbon dioxide and water. It is a sequence of elementary radical reactions, also leading to production of ashes.

e) *Thermo-chemical treatment/metallurgical treatment*: In the metallurgical treatment, the organic residues or their ashes are heated to temperatures between 800 and 1,500 °C to achieve a reconfiguration of solid materials, the chemical speciation of the P compounds can be modulated by addition of supplements like sand to increase plant P availability. In addition, thermal separation processes may also be combined with gasification of harmful trace elements.

Thermal treatment processes are among the most efficient methods to destroy harmful organic compounds, such as dioxins and furans, present in the solid residues^[10]. However, all the mentioned technologies result in losses of organic matter and

several volatile nutrients like nitrogen (N) and sulfur (S). Furthermore, the processes potentially transform organic and inorganic P molecules into P forms of low plant availability (see chapter «Fertilizer nutrient concentration») and potentially toxic elements (PTEs) are only partially removed. PTEs can be divided into easily volatile (e.g. Cd and Pb), semi volatile (e.g. Cu and Zn) and low volatile (e.g. As, Cr and Ni) elements. The availability of chlorine and the formation of metal chlorides may strongly increase the volatility of many metals^[10]. Therefore, different chlorine-containing additives (e.g. $CaCl_2$, $MgCl_2$, NaCl, etc.) have been used, and a vaporization of around 80–100 % of Cd and Pb was observed in most studies when temperature was over 850 °C^[10]. Nevertheless, the concentration of some of the PTEs in ashes often exceeds the legal limits for agricultural use^[11]. Hence, further treatment of ashes for PTE removal and P solubilization may improve its quality as a fertilizer for use in agriculture.

To improve the plant P availability and to reduce the PTE concentration of ashes several **approaches** have been developed in recent years, which can be categorized into three main groups:

1. *Direct use of P-rich ashes*: Ashes can be directly applied as fertilizer. In the fertilizer industry ashes can serve as substitutes for the finite resource phosphate rock. In this way, the available infrastructure and technologies are used for P-recovery.
2. *Wet chemical P extraction procedures*: Several technological approaches have been tested for wet chemical treatment of ashes, especially sewage sludge ashes, e.g. *Leachphos*, *EcoPhos* or *Recophos*. The basic idea is to solubilize P by the addition of acids (e.g. H_2SO_4 , HCl) and to produce either a water soluble fertilizer P product or a precipitated P fertilizer product (e.g. struvite). The acid consumption depends on the Ca and Fe content in the treated feedstock. PTEs are also dissolved by acid application. They can be removed by precipitation as sulfides or hydroxides, nanofiltration, extraction with solvents or ion-exchange resins^[14].
3. *Thermo-chemical treatment*: Thermo-chemical treatment procedures can be used to phase out PTEs and to transform the chemical bonding of P. Several technological approaches have been tested for thermo-chemical treatment of ashes, especially sewage sludge ashes, e.g. *ASH DEC* or *MEPHREC*, in order to produce fertilizer with similar characteristics as Rhenania- or Thomas-Phosphates.

Figure 2: Principle of thermo-chemical heavy metal (HM) removal in sewage sludge ash with MgCl₂ salts^[12]

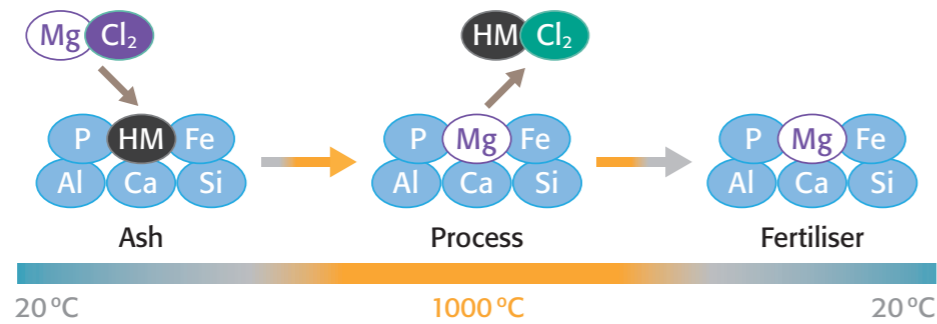

In the original ASH DEC process oxides of heavy metals form volatile metal-chloride and oxy-chloride complexes after application of MgCl₂ and are then separated from the ash by volatilization.

Originally, the ASH DEC process was based on the application of MgCl₂ and heating to temperatures of 800–1000 °C in a rotary kiln, resulting in the production of Mg-ashes (Mg-SSA = Magnesium treated Sewage Sludge Ash). In the presence of the chlorine donor, oxides of PTEs such as Cd, Cu, Hg, Pb, Mo, Sn and Zn form volatile metal-chloride and oxy-chloride complexes which are separated from the ash by volatilization via the off-gas^[11] according to the principle shown in Figure 2. This approach is theoretically still available as a process. However, the ASH DEC process was developed forward as a consequence of the low plant P availability under neutral and alkaline soil conditions of the Mg-ashes^[15]. The current industrial application foresees the use of sodium sulfates as additives to digest the ashes and produce Rhenanite (CaNaPO₄) as the major P-bearing mineral phase, a well-known P fertilizer (Rhenania phosphate) (Figure 3) with intermediate plant P availability. The process is based on calcining P containing minerals, a sodium source and silica (10:3.5:1.0) at 900 °C to 1000 °C^[16] ^[17]. More than 95% of the ash P is recovered by this process, the P concentration ranges between 6.5 and 11.0% on a DM base^[18]. The removal of PTEs is performed under reductive conditions: metal-

oxides are reduced to their elemental form, increasing the vapor pressure resulting in metallic vapors and their partial volatilization, and, further, collected in the flue dust. The new procedure is less efficient for removal of PTEs (e.g. no removal of Cr, Cu, Ni, low removal rate for Zn), a major advantage is the likely improved suitability of the obtained P fertilizer for calcareous soils^[19] ^[13].

The *Mephrec* treatment procedure, developed by INGITEC (Germany), combines ashing and the subsequent conditioning of the ashes, and is based on a reducing shaft melting gasification process (Figure 4). Inputs can be sewage sludge and many other inputs with a high energetic value like wood or meat and bone meal, as well as ashes. Dried sludge and/or sludge ashes are pressed into briquettes. The briquettes are thermally treated for gasification in a shaft furnace at temperatures above 1,450 °C. The obtained energy from the converter gas, the P containing slag as well as iron metal are the main outputs of this process.

To influence the P speciation in the P fertilizer quartz (SiO₂) is added, as the formation of silico-phosphates with a higher plant P availability is driven by the Si availability, and the cooling speed. A slow cooling induces the formation of silico-carno-

Figure 3: Improved ASH DEC process^[13]

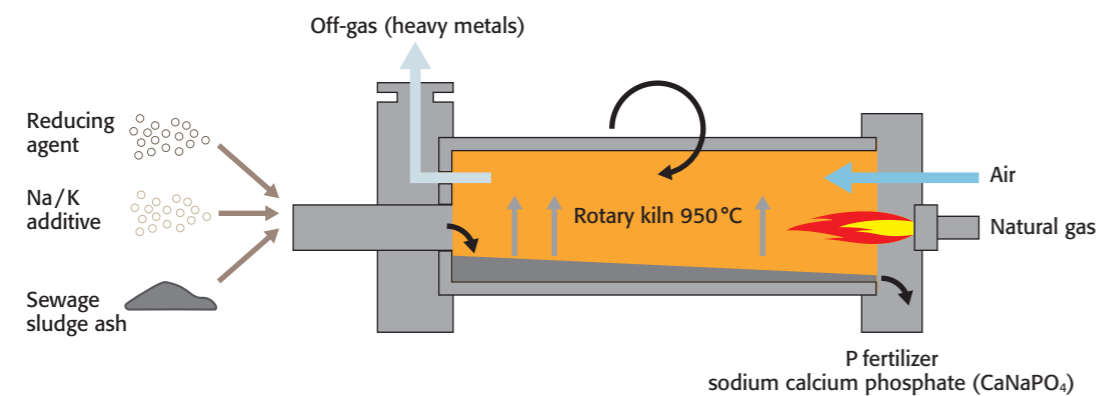

The improved ASH DEC process transforms ashes to sodium calcium phosphate (also called buchwaldite or rhenanite) – a P fertilizer similar to Rhenania phosphates.

Figure 4: Mephrec treatment procedure

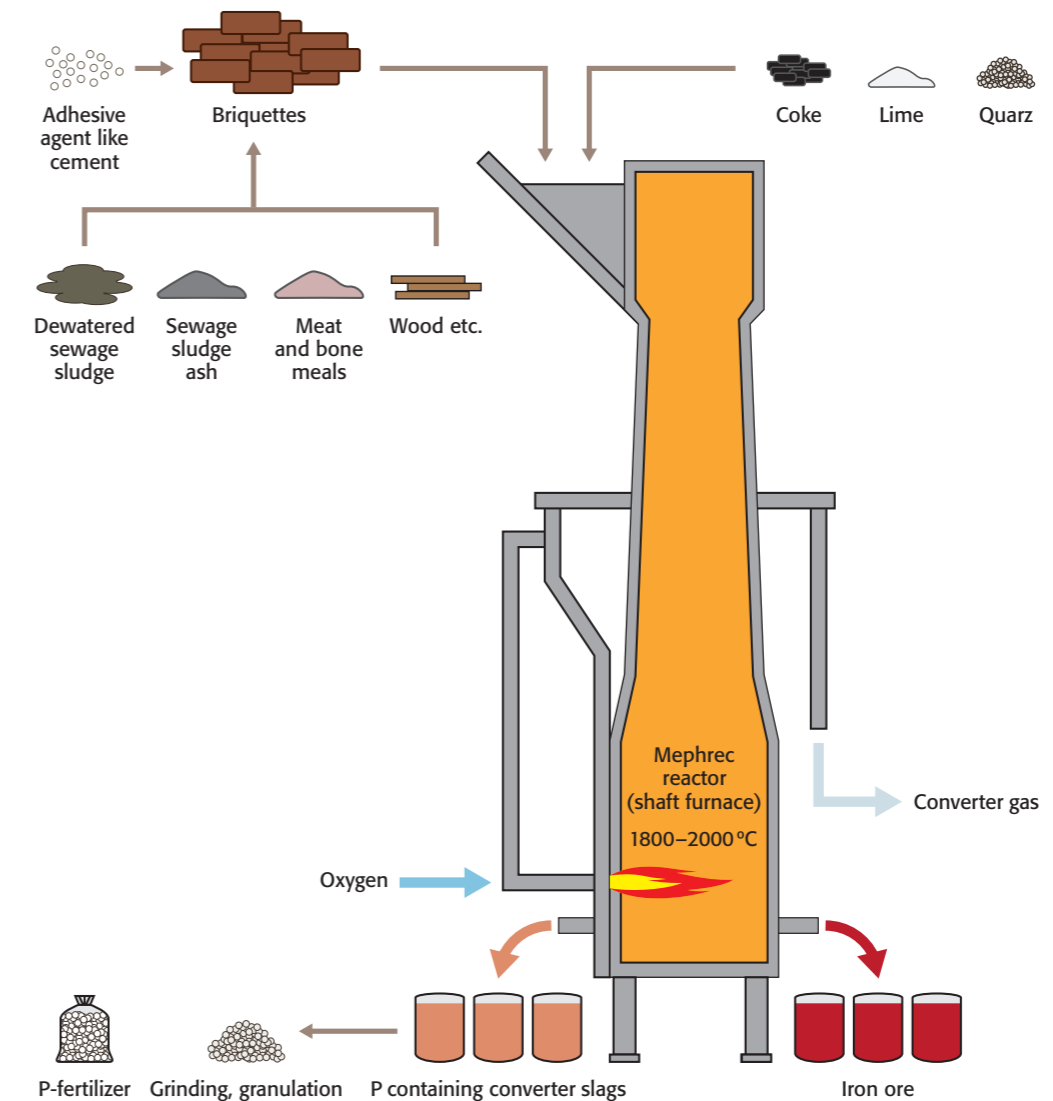

The *Mephrec* treatment converts inputs with a high energetic value in cupola furnaces to slags similar to traditional Thomas-phosphates.

tite (Ca₅(PO₄)₂SiO₄, or Ca₃(PO₄)₂*Ca₂SiO₄) with a high solubility in citric acid (approx. 90%)^[20]. The Si/P-ratio should be >0.28, as a lack of Si-ions can increase formation of tetra-calcium-phosphate (Hilgenstockit = Ca₄P₂O₉) with a low solubility in citric acid^[20]. In silico-carnotites the Si atom (or SiO₄⁴⁻-tetrahedra) replaces the P atoms (or PO₄³⁻-tetrahedra) with the subsequent charge imbalance in the crystal increasing their solubility^[21]. The P-availability is further influenced by the isomorphous substitution of the PO₄ tetrahedral ionic groups by carbonate (CO₃), as this isomorphous substitution also leads to structural instability of the crystal enhancing reactivity and plant P availability^[22]. The final product contains between 4.0 and 11.0% P in the DM representing approximately 80% P recovery rate from the input P^[18]. The P concentration in the fertilizer can vary according to the input feedstocks and their P concentration.

PTEs are chemically reduced under these conditions into their elemental form and some of them (Cd, Hg, Pb, Zn) are evaporated and separated via gas phase, whereas non-volatile PTEs (Fe, Cr, Cu, Ni) are separated from the slag in form of a liquid metal phase^[23]. Non-reduced oxides like SiO₂, CaO, MgO, Al₂O₃ as well as F (Fluor) and most of the remaining PTEs form a slag of lower specific gravity floating over the P and Fe containing metal phase. To separate Fe from the other components (e.g. P, but also C, Mn, Si, Ca, etc.), the metal phase is oxidized by addition of air (O₂) leading to the presence of Ca and the building of Ca-phosphates and other oxides. The P is accumulated in the slag and the aim is to manage the process to get a similar chemical bonding to thomas-phosphates (silico-phosphates)^[14]. A pilot plant is now under construction in Nuremberg/Germany to treat the dewatered sewage sludge from the entire region^[24].



Dried sludge pressed into briquettes before thermal treatment in a shaft furnace of a Mephrec-test facility at temperatures above 1,450°C.



Extraction of slag from a Mephrec-test facility.



The P containing converter slags obtained by the Mephrec treatment



Rhenanite pellets produced by ASH DEC. Their cylindrical shape is due to the production in a dye press.

Fertilizer nutrient concentration and characteristics

P concentration and P speciation

The P concentration of P fertilizers based on ashes depends largely on the source materials used, the combustion temperature and the P recovery treatment procedure (Table 1). With increasing treatment temperature, the pH, ash content and macro- and micronutrient content increased. Therefore, the total P concentration in sewage sludge ash ranges depending on its origin and the combustion temperature between 40 and 130 g P kg⁻¹ ash DM.

P bioavailability and influencing factors

The P fertilizer value of ashes depends on P speciation, and therefore also on the treatment procedure [25]. After combustion P will mainly be found in water-insoluble crystalline compounds [26] [27]. Incineration transforms organic and inorganic P molecules to crystalline molecules like Whitlockite (Ca₃(PO₄)₂) as well as Whitlockite-like compounds Ca₉Fe(PO₄)₇ or Ca₉MgK(PO₄)₇, Al-phosphates (AlPO₄) [28] [29], and at temperatures >700 °C the formation of hydroxyapatites (Ca₁₀(PO₄)₆(F,OH,Cl)₂) was observed [27].

The formation of insoluble minerals reduces water-solubility, and hence immediate plant avail-

ability. A low to moderate plant P availability is achieved in acidic soils and negligible levels in neutral soils [26] [28] [27] [29] [25] [30]. In chars obtained from hydrothermal carbonization (HTC-chars) and biochars obtained from pyrolysis, P is either incorporated in or occluded by the aromatic structures formed during treatment [31] [32]. The P forms in partially PTE depleted ashes (e.g. magnesium <Mg-SSA> or calcium <Ca-SSA> ashes) are semi-crystalline and dominated by Stanfieldite, followed by apatite and Farringtonite [33]. The dissolution of P in Mg-SSA and many other ashes is dependent on the acidity proton and the degree of P crystallinity determines P availability to plants [27] [30]. In an acidic soil, the relative P effectiveness of Mg-SSA in comparison to a water soluble P fertilizer is high with 88% and 71%, respectively. Mg-SSA applied to alkaline calcareous soil is not recommended, as the relative P efficiency is only 4%. Wet chemical treatments of ashes will provide fertilizers with high plant P availability [36].

Concerning Rhenanite, we know that it has a very low water solubility and a high citrate solubility with a moderate to high plant P availability even under neutral soil conditions [own unpublished results] [14]. The same was found for silico-carnotites (Thomas-phosphates) produced by the Mephrec treatment procedure.

In biochars, P will likely be associated with Ca and Mg due to biochar's elevated pH [34]. Hydrothermal carbonization leading to hydrochars also reduces the solubility of P in the solid phase by increasing the share of apatitic P [37]. Available P in biochars ranges from 0.4 to 34.0% of total P [34]. P availability depends on feedstock material and is inversely related to treatment temperature [38] [39] [40] [41].

Other nutrients, their speciation and plant bio-availability

By combustion or gasification treatment of sewage sludge organic compounds are removed (>99%) and only inorganic elements are present in ashes. Macro elements beside P are Si, Al, Fe, Mg, Ca and K. Nitrogen and S are more or less completely removed.

Organic matter

Combustion as well as gasification destroys most of the organic matter available in the feedstock, whereas hydrochars (from hydrothermal carbonization) and biochars (from pyrolysis) still contain parts of the organic matter. However, they differ in their physico-chemical properties, due to the specific production processes [42] [43]. Hydrochars contain less aromatic compounds and have higher O:C and H:C ratios and consequently, relatively small inner-surface areas [44] [42]. Biochars contain much more aromatic compounds with low molar O:C and H:C ratios, resulting in large inner surface areas. The high aromaticity of these compounds contributes to their high stability in soil [43]. The chemical composition and physical structure of biochars results in a higher resistance to microbial degradation compared to hydrochars [45] [40]. Additionally, hydrochars have a high dissolved organic-C content that provides microorganisms with an easily degradable C source [46], leading to N immobilization processes. In the long-term (several decades), both biochars and hydrochars will be degraded in soils like any other organic amendment, their high stability is relative.

Soil liming properties

The liming effect of chars and ashes may be quantified by calcium carbonate equivalency (CCE, the value relative to an equivalent quantity of CaCO₃). Combustion removes acidic functional groups (e.g. S, Cl), increasing the liming properties of the treated organic feedstock. The higher the combustion temperature, the higher the loss of acidic functional groups and therefore the CCE of the residual product [47] [48] [34]. The liming effect of biochars depends on the treatment procedure [47].

Pollutant contents

Potentially toxic element concentration, speciation and bioavailability

Varying PTE loads were reported depending on the different approaches for production of sewage sludge ash [36]. High PTE depletion rates are reported for wet chemical approaches (95–100%), partial depletion of PTEs with *AshDec*® and *Leachphos* (20–100%), and no depollution with *RecoPhos*® [49] [36]. In biochar and hydrochar production PTEs are concentrated with the exception of low-temperature sublimating elements such as mercury and cadmium [50]. It should be taken into consideration, that some of the processes addressed by Table 2 are not available at a commercial scale; therefore, the data should be carefully interpreted.

The heavy metal/nutrient relationship (HMN) is a dimensionless indicator for the PTE load related to the (plant) nutritional value of the fertilizers. The higher the value, the higher the PTE load relative to the benefit attainable by the fertilizer use. In general, the relationship of PTEs and plant nutrients is much lower in the PTE depleted P recycling fertilizer than in ashes or even traditional mineral P fertilizers like rock phosphates or Thomas slags (Thomas-phosphate) (Table 2, page 8).

Calculations of the long-term soil cadmium (Cd) accumulation risk for recycled P fertilizer using different kinds of ashes or struvite as recycled P fertilizer sources demonstrate a much lower accumulation risk than for green-waste composts already allowed for use in OF (Figure 5). Similar results were found for the other PTE included in this factsheet.

Table 1: Reported range of values for the nutrient composition (% of DM) of different P recycling products, compared with sewage sludge

	N	P	K	S	Mg	Ca	Si	References
Untreated sewage sludge ashes ¹⁾	–	7.09	0.69	1.21	1.31	13.7	13.3	[19]
Leachphos	–	13.1	0.3	4.7	0.8	14.9	1.9	[13]
Mg ashes (Ash Dec)	–	6.2	1.5		5.43	9.80	13.0	[15]
Rhenanite (Ash Dec)	–	7.7	1.2	2.6	1.3	9.3	10.9	[13]
Mephrec	–	4.59–5.24 9.0	<1	3.0	1.50–2.28 3.0	23.2–36.1 12.0	7.5–12.9 10.0	[23] [13]
Thomas-phosphate	–	7.6		0.1	1.26	33.8	2.34	[20]
Sewage sludge biochar	1.12	4.24	–	–	–	–	–	[34]
Food waste biochar	3.28	0.66	1.92	–	0.49	5.18	–	[34]
Sewage sludge	6.74	3.28	0.70	1.00	0.49	2.64	–	[35]

1) mean values for German sewage sludge ashes

The P concentration of the P recycling products based on ashes varies largely depending on the source materials used, the combustion temperature and the P recovery treatment procedure.



Recycled phosphorus fertilizers based on sewage sludge: from left: two struvites, Ca-phosphate, converter slag, biochar, biosolids ash.



Pot experiment with ash-based fertilizers.



Preparation of a field experiment to assess the P fertilizer effectiveness of recycled P fertilizers.



P containing biochar from sewage sludge pyrolysis after field application.

Figure 5: Calculation of the soil cadmium accumulation risk after long-term APF field application of 11 kg P/ha/yr on a dry, neutral soil (Weissengruber & Friedel, pers. communication)

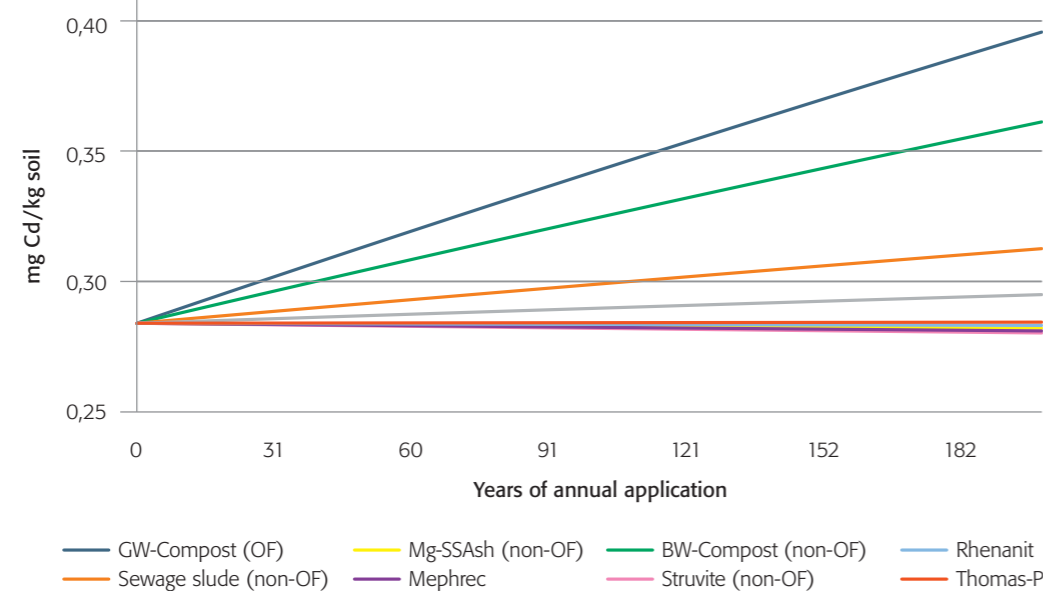

The long-term soil cadmium accumulation risk for recycled P fertilizer using different kinds of ashes or struvite as recycled P fertilizer sources is expected to be much lower accumulation risk than for green-waste composts (GW-Compost) allowed for use in organic farming.

Table 2: Potentially toxic element concentration [mg kg⁻¹ treated dry ash]¹⁾

	Zn	Cu	Pb	Cd	Ni	Hg	Cr	References	HMN ²⁾
Untreated sewage sludge ashes ³⁾	2479	875	129	3.47			233	[19]	0.90
Leachphos	1390	851	25	2.6	13.8	0.4	109	[13]	0.39
Mg ashes (ASH DEC) ⁴⁾	275 (41.1–188)	227 (10.5–249)	6.7 (<0.1–4.0)	0.2 (<0.1–0.1)	72 (31.1–72.4)		100 (58.1–120)	[15] [11]	0.44
Rhenanit (ASH DEC)	1710	601	60.1	0.3	56.4	0.3	127	[13]	0.55
Mephrec	85 79	74 97	20 20	0.014 <0.1	15 20	<0.1	1 83	[51] [13]	0.15 0.11
Thomas-phosphate	48	23.5	7.3	0.5	6.6		1545	[52]	1.24
Food waste biochar		222						[34]	
Phosphate rock	20.3 (4–130)	155 (6–500)	10 (3–35)	25 (0.2–60)	29 (2–37)	0.05 (0.01–0.06)	188 (1–225)	[53] [54]	0.99 (0.01–2.92)
Sewage sludge	823 (1–1420)	272 (107–664)	29.1 (5.0–83.2)	0.87 (0.22–1.57)	29.2 (7.0–85.0)	0.46 (0.10–2.27)	30.6 (13.0–78.0)	[35]	0.34

1) In parenthesis: range of values; 2) Heavy metal – nutrient relationship calculated according to [55], modified by [56]: the higher the value, the higher the toxic element flow related to the nutrient content of the fertilizer; 3) mean values for German sewage sludge ashes; 4) Seven different MgCl₂ treated sewage sludge ashes

The concentration of potentially toxic heavy metals and plant nutrients is much lower in the PTE depleted Mephrec-P recycling fertilizer and the Mg ashes and Rhenanit resulting from the ASH DEC process than in ashes or rock phosphate or Thomas slag.

Persistent organic pollutants and xenobiotics

Harmful organic pollutants are destroyed nearly completely by incineration [49][10]. Treatment in a furnace also destroys the persistent organic pollutants and xenobiotics [23][10]. The production of chars including HTC chars degrades some of the organic pollutants, however in many cases significant amounts of chlorinated aromatic compounds are formed as recalcitrant transformation products [57] [58].

Hygienic aspects

In sewage sludge ashes, a nearly total destruction of human pathogens is obtained [49]. A treatment above 850 °C inactivates even extremely persistent BSE prions in meat and bone meal [59]. The risk from use of the ash for the phosphate or fertilizer industry is negligible [60].

Other aspects

Available energy inputs data

Any treatment of stabilized sewage sludge is connected to additional energy inputs in comparison to the direct disposal of the sewage sludge [61]. Currently there are no data available for a thorough comparison of the different treatment technologies. Steinmetz et al. (2014) [19] summarized a need of 320 up to 600 kWh per ton of sewage sludge ash to perform the classical *Ash Dec* treatment procedure. The *Mephrec* treatment procedure has an energy demand of approx. 50 kWh + the energy present in the added coke. The energy demand of the Leachphos procedure is 500 kWh per ton treated ash, 100 kWh for leaching and precipitation, and 400 kWh for product drying.

Life Cycle Assessment

For all available P recovery strategies, the specific CO₂ emissions as well as the specific cumulative energy per kg P recovered is significantly higher than for 1 kg P of commercial fertilizer [49]. Linderholm et al. (2012) [61] showed that sludge application to farmland is a more efficient option in terms of energy and greenhouse gas emissions, compared to P recovery from incineration ashes. In this life cycle assessment, the energy costs of P-recovery from ashes was counted along with GHG emissions and the environmental cost of the N and S lost to air during the combustion process.

Conclusions

The use of phosphorus fertilizers derived from sewage sludge processed with various thermal treatments, possibly followed by a step of metallurgical conditioning, comprises promising options to recycle a significant proportion (80 to 90%) of P from the urban food chain back to the land by relatively sophisticated procedures, most of them leading to a significant reduction of organic pollutants including pharmaceuticals. The approaches very often include a step to remove potentially toxic elements. However, all thermal processes reduce the plant P availability and lead to significant losses of nitrogen and sulfur, downgrading the material from a fertilizer value perspective. Plant P availability can be improved by chemical treatment (similar to production of water-soluble mineral P fertilizers) or by implementation of more sophisticated treatments imitating the production process of Thomas or Rhenania phosphate fertilizers.

The trade-offs between potentially toxic element concentrations and beneficial elements may be more favorable for treated sewage products than for natural phosphate rocks, bio-waste composts or in some cases even animal manure. Combustion will also to a large extent destroy organic pollutants as well as pharmaceutical residues, and kill all pathogens. A major weaknesses of incineration are beside the volatilization and loss of N and S is, the degradation of the organic matter that could potentially improve soil quality, and the conversion of easily available phosphorus in human excreta into ashes with very low phosphorus solubility. For ashes and chars, their plant P availability at least under slightly acidic, neutral and alkaline soil conditions is very low. The risks of reducing the soil quality by xenobiotic compounds may be minor with incinerated products. For chars, more research is required to study the fate of organic and inorganic pollutants.

Permission to use such fertilizers in organic farming in the EU would contribute to better nutrient cycling between rural and urban areas, reduce problems of declining phosphorus concentrations in some organic farming systems and could also contribute to the development of practical methods for processing sewage.

Assessment of the suitability for use in Organic Farming

According to regulation (EC) No 889/2008 only ashes obtained from combustion or incineration of chemically untreated wood are allowed as fertilizer in organic farming. Ashes containing any other feedstock are not allowed for use, excluding most urban recycling P sources.

A compliance with organic ideas includes at least five aspects:

- 1) The efficiency in terms of the proportion of nutrients recovered by the process
- 2) The processes and additives applied to obtain the fertilizer, their potential environmental impact
- 3) The fertilizer's mode of action in the soil and fertilizing efficiency
- 4) The effects on regional nutrient cycles and long term preservation of the soil fertility
- 5) The potential long term effects on soil contamination and environmental pollution.

Regarding the efficiency, the use of ashes from biogenic waste incineration is one mean to close the currently open gap in P recycling in the organic food chain and meets the basic ideas of organic farming. It is much more efficient in P recovery (up to 90%) than precipitation procedures for P recycling like struvite crystallization (up to 50–60%), as precipitation procedures can only recover dissolved inorganic P fractions, and no organic P compounds.

Regarding the processes and additives, combustion, gasification, pyrolysis and hydrothermal carbonization of dry organic matter do not need major additives and these processes mostly provide a net energetic gain. However, the more sophisticated treatment procedures to reduce the PTE load of ashes and to improve the plant P availability need several additives, e.g. high acid needs, mainly for ashes high in Fe or Ca. Therefore, chemical and thermo-chemical treatment options based on acid dissolution of P should be preferentially used for low Fe-ashes, whereas Fe-rich ashes should be preferentially treated in furnaces (Mephrec), where iron, phosphates as well as PTEs could be recovered in separate fractions/layers within the furnace. The energy output for pyrolysis and hydrothermal carbonization is much lower than for combustion or gasification, as part of the organic matter remain in the residue. Wet-chemical processes are very similar to the conventional production of water-soluble mineral P fertilizers, whereas the additives needed to carry out the thermo-chemical procedures are more in compliance with current organic regulations. A special advantage of the thermo-chemical processes like Mephrec or ASH DEC is that they not only transform a contaminated waste with high levels of pollutants into valuable P fertilizer but also produce several streams of other recycling materi-

als that can be used in other industrial applications. They include a Fe-containing metal ore, a silicate slag for use as a binder in the cement industry and syngas with high energy concentration for energy generation.

Regarding the fertilizer's mode of action, the water solubility of chars and of the ashes and products obtained from ashes is very low (exception: P fertilizers from wet chemical procedures). A relevant weakness of any incineration process is the transformation of easily available P forms like water soluble or adsorbed ortho-P into phosphates of Ca, Fe, Mg, etc., resulting in a strong reduction of the plant P availability. The obtained ashes are often not suited to overcome P deficiencies especially in neutral or calcareous soils.

Regarding the effects on regional nutrient cycles, combustion or gasification of organic wastes may imply an efficient recycling of P and provides liming components to the soil to reduce soil acidity. However, important components for soil fertility like the organic matter, the N and S become volatilized during combustion or gasification and must be supplemented by other sources. This is a major weakness of these treatment processes.

Regarding the potential long term effects, moderate soil P fertilization with ashes based on balancing P outputs from via sold farm products has only a minor influence on soil Cd accumulation. Also, the inactivation of pathogens, the removal of persistent organic pollutants and xenobiotics in the ashes meets basic organic ideas (precautionary principle). Chars have a higher risk of organic pollutants accumulation in soils, as the removal efficiency is lower than in incineration processes.

References

- 1 Cascarosa, E., G. Gea, J. Arauzo (2012): Thermochemical processing of meat and bone meal: A review. *Renewable and Sustainable Energy Reviews* 16, 942–957.
- 2 Donatello, S., C.R. Cheeseman (2013): Recycling and recovery routes for incinerated sewage sludge ash (ISSA): A review. *Waste Management* 33, 2328–2340.
- 3 Zhang, Q., H. Liu, W. Li, J. Xu, Q. Liang (2012): Behavior of phosphorus during co-gasification of sewage sludge and coal. *Energy Fuels*, 26, 2830–2836.
- 4 Kupper, T. (2008): Belastung und Quellen organischer Schadstoffe im Klärschlamm und ihre Bedeutung im Zusammenhang mit dem Ausstieg aus der landwirtschaftlichen Klärschlammverwertung in der Schweiz. *Österreichische Wasser- und Abfallwirtschaft* 60, 45–54.
- 5 Pinnekamp, J. (2007): Thermische Klärschlammbehandlung in Deutschland sowie Verfahren zur Phosphorrückgewinnung aus Asche. In: *Phosphorrecycling – Rückgewinnung von industriell bzw. landwirtschaftlich verwertbaren Phosphorverbindungen aus Abwasser und Klärschlamm*. Institut für Siedlungswasserwirtschaft RWTH Aachen, Aachen.
- 6 Knappe, F., A. Böß, H. Fehrenbach, J. Giegrich, R. Vogt (2007): Stoffstrommanagement von Biomasseabfällen mit dem Ziel der Optimierung der Verwertung organischer Abfälle. <http://www.umweltbundesamt.de>, downloaded 23 April 2012.
- 7 Hermann, L. (2009): Rückgewinnung von Phosphor aus der Abwassereinigung. Eine Bestandesaufnahme. Bundesamt für Umwelt, Bern.
- 8 Funke, A., J. Mumme, M. Koon, M. Diakite (2013): Cascaded production of biogas and hydrochar from wheat straw: Energetic potential and recovery of carbon and plant nutrients. *Biomass and Bioenergy* 58, 229–237.
- 9 Sori, S., Lopez-Capel, E., Krull, E., & Bol, R. (2009): Biochar, climate change and soil: A review to guide future research (pp. 1–57). Glen Osmond, Australia: CSIRO.
- 10 Lindberg, D., C. Molin, M. Hupa (2015): Thermal treatment of solid residues from WTE units: A review. *Waste Management*, 37, 82–94.
- 11 Adam, C., B. Peplinski, M. Michaelis, G. Kley, F.G. Simon (2009): Thermo-chemical treatment of sewage sludge ashes for phosphorus recovery. *Waste Management* 29, 1122–1128.
- 12 Adapted from Hermann 2016, www.outotec.com.
- 13 Stemmann, J., B. Peplinski, C. Adam (2014): Thermo-chemical treatment of sewage sludge ash with sodium salt additives for phosphorus fertilizer production – Analysis of underlying chemical reactions. *Waste Management* 45, 385–390.
- 14 Nanzer, S., A. Oberson, L. Berger, E. Berset, L. Hermann, E. Frossard (2014a): The plant availability of phosphorus from thermo-chemically treated sewage sludge ashes as studied by 33P labelling techniques. *Plant and Soil*, 1–18.
- 15 Bolan, N. S., M.J., Hedley, P. Loganathan (1993): Preparation, forms and properties of controlled-release phosphate fertilizers. *Fertilizer research* 35, 13–24.
- 16 Stemmann, J., B. Peplinski, C. Adam (2015): Thermo-chemical treatment of sewage sludge ash with sodium salt additives for phosphorus fertilizer production – Analysis of underlying chemical reactions. *Waste Management* 45, 385–390.
- 17 NN (2015): Ashdec® Thermo-chemical ash treatment. P-REX Factsheet. Available at: http://p-rex.eu/uploads/media/PREX_Factsheet_ASHDEC.pdf.
- 18 Steinmetz, H., C. Meyer, T. Reinhardt (2014): Interkommunales Pilotprojekt zur Phosphorrückgewinnung aus Klärschlammaschen in Baden-Württemberg.
- 19 Herzel, H., O. Krüger, L. Hermann, C. Adam (2016): Sewage sludge ash – A promising secondary phosphorus source for fertilizer production. *Science of The Total Environment* 542, 1136–1143.
- 20 Gericke, S. (1968): Thomasphosphat. In: Linser, H. (ed.): *Handbuch der Pflanzenernährung und Düngung*. Springer, Wien – New York, pp. 1168–1202.
- 21 Gomes, S., J.M. Nedelec, E. Jallot, D. Sheptyakov, G. Renaudin (2011): Silicon location in silicate-substituted calcium phosphate ceramics determined by neutron diffraction. *Crystal growth & design*, 11(9), 4017–4026.
- 22 Kratz, S., E. Schnug (2008): Zur Frage der Löslichkeit und Pflanzenverfügbarkeit von Phosphor in Düngemitteln. URL: http://www.ulmer.de/Artikel_dll/kratz-andschnug_ODUyMTU3.PDF.
- 23 Scheidig, K. (2009): Wirtschaftliche und energetische Aspekte des Phosphor-Recyclings aus Klärschlamm. In: KA – Korrespondenz Abwasser, Abfall 56, 1138–1146.
- 24 Hagspiel, B., P. Pluschke (2014): Klärschlammverwertung Region Nürnberg – Klärschlamm zu Energie und Dünger.
- 25 Ippolito, J.A., K.A. Spokas, J.M. Novak, R.D. Lentz, K.B. Cantrell (2015): Biochar elemental composition and factors influencing nutrient retention. *Biochar for Environmental Management: Science, Technology and Implementation*, second ed. Routledge, New York, NY, 139–163.
- 26 Heck, A. (2014): VDLUFA – QLA GmbH, Rheinbach, personal communication.
- 27 Nanzer, S., A. Oberson, T. Huthwelker, U. Eggenberger, E. Frossard (2014b): The Molecular Environment of Phosphorus in Sewage Sludge Ash: Implications for Bioavailability. *J. Environ. Qual.* 43, 1050–1060.
- 28 Møller, H.B., H.S. Jensen, L. Tobiasen, M.N. Hansen (2007): Heavy metal and phosphorus content of fractions from manure treatment and incineration. *Environ. Technol.*, 28, 1403–1418.
- 29 Thygesen, A., O. Wernberg, E. Skou, S.G. Sommer (2011): Effect of incineration temperature on phosphorus availability in bio-ash from manure. *Environ. Technol.* 32, 633–638.
- 30 Peplinski, B., C. Adam, M. Michaelis, G. Kley, F. Emmerling, F.G. Simon (2009): Reaction sequences in the thermo-chemical treatment of sewage sludge ashes revealed by X-ray powder diffraction – A contribution to the European project SUSAN. *Zeitschrift für Kristallographie* 30, 459–464.
- 31 Komiyama, T., A. Kobayashi, M. Yahagi (2013): The chemical characteristics of ashes from cattle, swine and poultry manure. *J. Mater Cycles Waste Management*. 15, 106–110.
- 32 Vogel, T., M. Nelles, B. Eichler-Loebermann (2015): Phosphorus application with recycled products from municipal waste water to different crop species. *Ecological Engineering* 83, 466–475.
- 33 Cantrell, K.B., P.G. Hunt, M. Uchimiya, J.M. Novak, K.S. Ro (2012): Impact of pyrolysis temperature and manure source on physico-chemical characteristics of biochar. *Bioresource Technology* 107, 419–428.
- 34 Tsai, W., S. Liu, H. Chen, Y. Chang, Y. Tsai (2012): Textural and chemical properties of swine-manure-derived biochar pertinent to its potential use as a soil amendment. *Chemosphere*, 89, 198–203.
- 35 Nanzer, S. (2013): Evaluation of a phosphate fertilizer from sewage sludge ashes: A journey from the molecule to the field. Diss. ETH Zürich.
- 36 Egle, L., H. Rechberger, M. Zessner (2014): Vergleich von Verfahren zur Rückgewinnung von Phosphor aus Abwasser und Klärschlamm. *Österreichische Wasser- und Abfallwirtschaft* 66, 30–39.
- 37 Dai, L., F. Tan, B. Wu, M. He, W. Wang, X. Tang, ... M. Zhang (2015): Immobilization of phosphorus in cow manure during hydrothermal carbonization. *Journal of environmental management* 157, 49–53.
- 38 Chan, K.Y., L. Van Zwielen, I. Meszaros, A. Downie, S. Joseph (2007): Agronomic values of greenwaste biochar as a soil amendment. *Australian Journal of Soil Research* 45, 629–634.
- 39 Gaskin, J.W., C. Steiner, K. Harris, K.C. Das, B. Bibens (2008): Effect of low-temperature pyrolysis conditions on biochar for agricultural use. *Transactions of the American Society of Agricultural and Biological Engineers* 51, 2061–2069.
- 40 Qayyum, M.F., D. Steffens, H.P. Reisenauer, S. Schubert (2012): Kinetics of carbon mineralization of biochars compared with wheat straw in three soils. *J. Environ. Qual.* 41, 1210–1220.
- 41 Zheng, H., Z., Wang, X. Deng, J. Zhao, Y. Luo, J. Novak, S. Herbert, B. Xing (2013): Characteristics and nutrient values of biochars produced from giant reed at different temperatures. *Bioresource Technology* 130, 463–471.
- 42 Libra, J.A., K.S. Ro, C. Kammann, A. Funke, N.D. Berge, Y. Neubauer, M.M. Titirici, C. Fühner, O. Bens, J. Kern, K.H. Emmerich (2011): Hydrothermal carbonization of biomass residuals: A comparative review of the chemistry, processes and applications of wet and dry pyrolysis. *Biofuels* 2, 71–106.
- 43 Stimmelpfennig, S., B. Glaser (2012): One step forward toward characterization: Some important material properties to distinguish biochars. *J. Environ. Qual.* 41, 1001–1013.
- 44 Fuertes, A.B., M. Camps Arbostain, M. Sevilla, J.A. Maciá-Agulló, S. Fiol, R. López, R.J. Smernik, W.P. Aitkenhead, F. Arce, F. Macias (2010): Chemical and structural properties of carbonaceous products obtained by pyrolysis and hydrothermal carbonization of corn stover. *Aust. J. Soil Res.* 48, 618–626.
- 44 Steinbeiss, S., G. Gleixner, M. Antonietti (2009): Effect of biochar amendment on soil carbon balance and soil microbial activity. *Soil Biol. Biochem.* 41, 1301–1310.
- 45 Bargmann, I., R. Martens, M.C. Rillig, A. Kruse, M. Kücke (2014): Hydrochar amendment promotes microbial immobilization of mineral nitrogen. *Journal of plant nutrition and soil science* 177, 59–67.
- 46 Hass, A., J.M., Gonzalez, I.M. Lima, H.W. Godwin, J.J. Halvorson, D.G. Boyer (2012): Chicken manure biochar as liming and nutrient source for acid Appalachian soil. *Journal of Environmental Quality* 41, 1096–1106.
- 47 Wang, T., M. Camps-Arbostain, M. Hedley, P. Bishop (2012a): Predicting phosphorus bioavailability from high-ash biochars. *Plant and soil* 357, 173–187.
- 48 Egle, L., H. Rechberger, M. Zessner (2013): (Comparative) Technical, environmental and economic assessment of Phosphorus recycling technologies from waste water. Presentation on the International Symposium Re-Water in Braunschweig/Germany; 06.11.2013–07.11.2013. Available at: http://www.re-water-braunschweig.de/files/egle_et_al_tech_envir_econom_assessment_p-recycling_technologies.pdf. Downloaded September 4, 2014.
- 49 Bridle, T.R., D. Pritchard (2004): Energy and nutrient recovery from sewage sludge via pyrolysis. *Water Sci. Tech.* 50, 169–175.
- 50 Scheidig, K., J. Mallon, M. Schaaf (2014): Metallurgisches Phosphor-Recycling mit dem Mephrec-Verfahren. Workshop BAM Berlin, 28 and 29 January 2014.
- 51 Kerschberger, M., G. Franke, W. Schuricht (2001): Schwermetallgehalte in landwirtschaftlich relevanten Stoffen. *Archives of Agronomy and Soil Science* 46, 147–164.
- 52 Mortvedt, J.J. (1996): Heavy metal contaminants in inorganic and organic fertilizers. *Fertilizer research* 43, 55–61.

- 53 Dissanayake, C.B., R. Chandrajith (2009): Phosphate mineral fertilizers, trace metals and human health. *Journal of the National Science Foundation of Sri Lanka* 37, 153–165.
- 54 Herter, U., D. Külling (2001): Risikoanalyse zur Abfalldüngerverwertung in der Landwirtschaft. Bericht Juli 2001. Eidgenössische Forschungsanstalt für Agrarökologie und Landbau Reckenholz (Hg.), Zürich.
- 55 Möller, K., U. Schultheiß (2014): Organische Handelsdüngemittel im ökologischen Landbau – Charakterisierung und Empfehlungen für die Praxis. *KTBL-Schrift* 499. KTBL, Darmstadt, 392 pp.
- 56 Weiner, B., I. Baskyr, J. Poerschmann, F.D. Kopinke (2013): Potential of the hydrothermal carbonization process for the degradation of organic pollutants. *Chemosphere* 92, 674–680.
- 57 Oleszczuk, P., A. Zielinska, G. Cornelissen (2014): Stabilization of sewage sludge by different biochars towards reducing freely dissolved polycyclic aromatic hydrocarbons (PAHs) content. *Biore-source technology* 156, 139–145.
- 58 NABC (2004): Carcass disposal: a comprehensive review. Report written for the USDA Animal and Plant Health Inspection Service. National Agricultural Biosecurity Centre, Kansas State University.
- 59 Paisley, L.G., J. Hostrup-Pedersen (2005): A quantitative assessment of the BSE risk associated with fly ash and slag from the incineration of meat-and-bone meal in a gas-fired power plant in Denmark. *Preventive veterinary medicine* 68, 263–275.
- 60 Linderholm, K., A.-M. Tillman, J.E. Mattsson (2012): Life cycle assessment of phosphorus alternatives for Swedish agriculture. *Resources, Conservation and Recycling* 66, 27–39.

Additional literature

- Adam, C. (2008): Final Activity Report. In: "SUSAN – Sustainable and Safe Re-use of Municipal Sewage Sludge for Nutrient Recovery".
- Ahmad, M., S.S. Lee, X. Dou, D. Mohan, J. Sung, J.E. Yang (2012): Effects of pyrolysis temperature on soybean stover- and peanut shell-derived biochar properties and TCE adsorption in water. *Biore-source Technology* 118, 536–544.
- Binder, C. R., L. de Baan, D. Wittmer (2009): Phosphorflüsse in der Schweiz. Stand, Risiken und Handlungsoptionen. Abschlussbericht. Bundesamt für Umwelt, Bern.
- Jeffery, S., F.G.A. Verheijen, M. Van Der Velde, A.C. Bastos (2011): A quantitative review of the effects of biochar application to soils on crop productivity using meta-analysis. *Agriculture, ecosystems & environment* 144, 175–187.
- Jensen, L.S. (2013): Animal manure residue upgrading and nutrient recovery in biofertilizers. In: *Animal Manure Recycling, Treatment and Management*, In: S.G. Sommer, M.L. Christensen, T. Schmidt, L.S. Jensen (Eds.), John Wiley & Sons Ltd., 271–294.
- Novak, J.M., I. Lima, B. Xing, J.W. Gaskin, C. Steiner, K.C. Das, M. Ahmedna, D. Rehrh, D.W. Watts, W.J. Busscher, H. Schomberg (2009): Characterization of designer biochar produced at different temperatures and their effects on a loamy sand. *Annals of Environmental Science* 3, 195–206.
- Reuter, M., Y. Xiao, U. Boin (2004): Recycling and environmental issues of metallurgical slags and salt fluxes. VII International Conference on Molten Slags Fluxes and Salts. The South African Institute of Mining and Metallurgy, pp. 349–356.
- Shackley, S., Ruyschaert, G., Zwart, K., & Glaser, B. (Eds.) (2016): *Biochar in European Soils and Agriculture: Science and Practice*. Routledge.
- Simon, O. (2014): Pilot investigation of the efficiency of a wet chemical process for phosphorus recovery from sewage sludge ash. http://www.fhnw.ch/lifesciences/master/master-thesis/MS_ET_Obrist_Simon_2014.pdf, downloaded Sept. 3, 2014.
- Wang, J., X. Pan, Y. Liu, X. Zhang, Z. Xiong (2012b): Effects of biochar amendment in two soils on greenhouse gas emissions and crop production. *Plant and Soil* 360, 287–298.
- Wang, T., M. Camps-Arbestain, M. Hedley (2014): The fate of phosphorus of ash-rich biochars in a soil-plant system. *Plant and soil* 375, 61–74.

Imprint

Editors:

Universität Hohenheim
Institute of Crop Science
Fertilisation and Soil Matter Dynamics Group (340i)
Fruwirthstraße 20, D-70599 Stuttgart, Germany
Contact person: Dr. Kurt Möller
kurt.moeller@alumni.tum.de
<https://plantnutrition.uni-hohenheim.de/>

ETH Zürich
Plant Nutrition Group
Eschikon 33, CH-8315 Lindau, Switzerland
Contact person: Dr. Astrid Oberson
astrid.oberson@usys.ethz.ch
www.plantnutrition.ethz.ch

Research Institute of Organic Agriculture (FiBL)
Ackerstrasse 113, Postfach 219, CH-5070 Frick, Switzerland
Contact person: Dr. Paul Mäder
paul.maeder@fibl.org
info.suisse@fibl.org, www.fibl.org

Research Institute of Organic Agriculture (FiBL)
Doblhofgasse 7/10, A-1010 Wien, Austria
Contact Person: Dr. Stefan Hörtenhuber
stefan.hoertenhuber@fibl.org
info.oesterreich@fibl.org, www.fibl.org

Bioforsk
Norwegian Institute for Agricultural and Environmental Research
Organic Food and Farming Group
Gunnars veg 6, 6630 Tingvoll, Norway
Contact person: Dr. Anne-Kristin Løes
anne-kristin.loes@norsok.no
www.bioforsk.no

Universität für Bodenkultur Wien
Institut für Ökologischen Landbau
Gregor Mendel Strasse 33, A-1180 Wien, Austria

Contact person: Prof. Dr. Jürgen Friedel
juergen.friedel@boku.ac.at
www.nas.boku.ac.at/foel

Newcastle University
Nafferton Ecological Farming Group
Stocksfield, NE43 7XD, United Kingdom
Contact person: Dr Julia Cooper
julia.cooper@ncl.ac.uk
www.nefg-organic.org

University of Copenhagen
Department of Plant and Environmental Sciences
Thorvaldsensvej 40, DK-1871 Frederiksberg, Denmark
Contact person: Dr. Jakob Magid, jma@plen.ku.dk
<http://plen.ku.dk/english/>

Author: Kurt Möller (Institute of Crop Science, University of Hohenheim, Germany)

Reviewers: Astrid Oberson (ETH Zürich, Switzerland), Anne-Kristin Løes (Bioforsk, Norway), Julia Cooper (University of Newcastle, UK), Paul Mäder (FiBL), Iris Wollmann (Institute of Crop Science, University of Hohenheim, Germany)

English editing: Julia Cooper (Newcastle University)

General editing: Bettina Billmann (FiBL)

Layout: Brigitta Maurer (FiBL)

Photos: Thomas Alföldi (FiBL): page 1; Klärschlammverwertung Nürnberg GmbH: p. 6 (1); Reto Manitz (Manitz Kommunikation): p. 6 (2); Outotec GmbH: p. 1, 7 (2); Iris Wollmann: p. 7 (1); 8, 9

FiBL-Order Nr. 1709

ISBN-PDF 978-3-03736-344-7

This fact sheet is available for free download at <https://improve-p.uni-hohenheim.de/andshop.fibl.org>

© 2016

Acknowledgement: The partners of the IMPROVE-P consortium gratefully acknowledge the financial support for this project provided by the CORE Organic II Funding Bodies, being partners of the FP7 ERA-Net project, CORE Organic II (Coordination of European Transnational Research in Organic Food and Farming systems).

For further information see: www.coreorganic2.org. For more information on the project consult the project website <https://improve-p.uni-hohenheim.de/>.

