TECHNISCHE UNIVERSITÄT MÜNCHEN

Fachgebiet Obstbau

Entomopathogenic fungi as a new strategy to control the European cherry fruit fly
Rhagoletis cerasi Loew (Diptera: Tephritidae).

Claudia Daniel

Vollständiger Abdruck der von der Fakultät Wissenschaftszentrum Weihenstephan für
Ernährung, Landnutzung und Umwelt der Technischen Universität München zur Erlangung
des akademischen Grades eines

Doktors der Agrarwissenschaften

genehmigten Dissertation.

Vorsitzender: Univ.-Prof. Dr. J. Meyer
Prüfer der Dissertation: 1. Univ.-Prof. Dr. D.R. Treutter
2. Univ.-Prof. Dr. R. Schopf

Die Dissertation wurde am 14.10.2008 bei der Technischen Universität München eingereicht
und durch die Fakultät Wissenschaftszentrum Weihenstephan für Ernährung, Landnutzung
und Umwelt am 08.01.2009 angenommen.

Die Kirschfliege (*Spilographa cerasi* L.) hat in den Gubener Bergen dieses Jahr so stark gehaust, dass den dortigen Winzern trotz der guten Kirschernte ein bedeutender Ausfall ihrer Einnahmen erwachsen ist, da der grössere Theil der Kirschen nicht einmal für das Pflückerlohn verkäuflich war. Da die Kirsche auf den dortigen Sandhügeln so vorzüglich, wie keine andere Frucht gedeiht und früher die höchste Rente des Sandbodens ergab, so sehen die Winzer mit Bekümmerniss in die Zukunft.

Karsch, F. (1889). Oekonomisch-entomologische Notizen: Die Kirschenfliege. -- Entomologische Nachrichten 15, 384.

Im Auftrage des Kgl. preussischen Ministeriums für Landwirtschaft habe ich die Entwicklung dieses Parasiten in Guben genau untersucht, um die geeigneten Mittel zur Bekämpfung desselben ausfindig zu machen. Es ist in der That gelungen, die Lebensweise dieses Tieres nach allen Richtungen aufzuklären und die zweifelhaften Fragen zu erledigen, so dass jetzt genau der Weg vorgezeichnet ist, welcher sicher zu einer erfolgreichen Bekämpfung des Tieres führen muss.

Frank, B. (1891). Über die Kirschenfliege *Spilographa cerasi* und ihre Bekämpfung. -- Zeitschrift für Pflanzenkrankheiten 1, 284-287.

Ueber die Lebensgeschichte der Kirschfliege, d. i. die alte Linné'sche *Musca cerasi*, ist schon manches geschrieben worden.*) Ich halte es aber nicht für überflüssig, hierüber noch einmal zu handeln, in der Meinung, dass sich daraus vielleicht doch noch ein oder der andere neue Gesichtspunkt über diesen Gegenstand ergeben wird.

Mik, J. (1898). Zur Biologie von *Rhagoletis cerasi* L. nebst einigen Bemerkungen über die Larven und Puparien der Trypetiden und über die Fühler der Musciden-Larven. -- Wiener Entomologen Zeitung 17, 279-313.

Table of contents

1. SUMMARY	5
2. ZUSAMMENFASSUNG	7
3. INTRODUCTION	9
4. OBJECTIVES AND STRUCTURE OF THE THESIS	10
5. BIOLOGY OF <i>R. CERASI</i>.....	11
5.1. Taxonomy, geographic distribution and host plants	11
5.2. Adult emergence	12
5.3. Pre-oviposition period	14
5.4. Mating.....	15
5.5. Oviposition.....	16
5.6. Dispersion	17
5.7. Larval development.....	18
5.8. Pupation and diapause	19
5.9. Population dynamics and abiotic mortality factors.....	21
5.10. Antagonists of <i>R. cerasi</i> and other Tephritidae.....	22
5.11. History of cherry fruit fly control	24
PART A – LABORATORY EXPERIMENTS WITH ENTOMOPATHOGENIC FUNGI	27
A.1. Introduction	27
A.2. Materials & methods	27
A.2.1. <i>Source of insects</i>	27
A.2.2. <i>Source and culture of entomopathogenic fungi</i>	28
A.2.3. <i>Experiments with adult <i>R. cerasi</i></i>	29
A.2.4. <i>Soil treatments to control emerging flies</i>	30
A.2.5. <i>Efficacy of different fungus isolates on larvae of <i>R. cerasi</i></i>	31
A.2.6. <i>Statistical analysis</i>	32
A.3. Results	32
A.3.1. <i>Experiments with adult <i>R. cerasi</i></i>	32
A.3.2. <i>Soil treatments to control emerging flies</i>	39
A.3.3. <i>Efficacy of different fungus isolates against larvae of <i>R. cerasi</i></i>	40
A.4. Discussion	41
PART B – SOIL NETTING TO EVALUATE THE GENERAL EFFICACY OF SOIL TREATMENTS FOR CONTROLLING <i>R. CERASI</i>	45
B.1. Introduction	45
B.2. Materials & methods	46
B.3. Results	48
B.4. Discussion	52
PART C – SEMI-FIELD EXPERIMENTS TO EVALUATE THE EFFICACY OF SOIL TREATMENTS WITH ENTOMOPATHOGENIC FUNGI.....	53
C.1. Introduction	53
C.2. Materials & methods	53
C.2.1. <i>Experiments in 2006</i>	53
C.2.2. <i>Experiment in 2007</i>	55
C.3. Results	56
C.3.1. <i>Experiments in 2006</i>	56
C.3.2. <i>Experiments in 2007</i>	57
C.4. Discussion	58
PART D – TRAPS AND BAITS: A PREREQUISITE FOR ATTRACT-AND-KILL STRATEGIES	62
D.1. Introduction	62
D.2. Materials & methods	63
D.2.1. <i>Experimental orchards and experimental design</i>	63

D.2.2.	<i>Traps and baits</i>	65
D.2.3.	<i>Evaluations</i>	65
D.2.4.	<i>Statistical analysis</i>	68
D.3.	Results	69
D.3.1.	<i>Comparison of standard traps over three years</i>	69
D.3.2.	<i>Comparison of different baits</i>	70
D.3.3.	<i>Side effects of traps and baits on non-target arthropods</i>	79
D.4.	Discussion	81
PART E – FOLIAR APPLICATIONS OF MYCOPESTICIDES FOR CONTROLLING <i>R. CERASI</i>		87
E.1.	Introduction	87
E.2.	Materials & methods	87
E.2.1.	<i>Applications of mycopesticides in 2006 and 2007</i>	87
E.2.2.	<i>Persistence of fungal propagules on the phylloplanes</i>	89
E.3.	Results	90
E.3.1.	<i>Applications of mycopesticides in 2006 and 2007</i>	90
E.3.2.	<i>Persistence of fungal propagules on the phylloplanes</i>	93
E.4.	Discussion	95
PART F – REPELLENT AND OVIPOSITION DETERRENT EFFECT OF OIL PRODUCTS AND OF NATURALIS-L		99
F.1.	Introduction	99
F.2.	Materials & methods	99
F.2.1.	<i>Laboratory experiment</i>	99
F.2.2.	<i>Semi-field experiment</i>	100
F.2.3.	<i>Field experiment</i>	101
F.3.	Results	101
F.3.1.	<i>Laboratory experiment</i>	101
F.3.2.	<i>Semi-field experiment</i>	102
F.3.3.	<i>Field experiment</i>	103
F.4.	Discussion	104
PART G – OCCURRENCE OF THE AMERICAN CHERRY FRUIT FLIES <i>R. INDIFFERENS</i> & <i>R. CINGULATA</i>		106
G.1.	Introduction	106
G.2.	<i>R. cingulata</i> or <i>R. indifferens</i> ?.....	106
G.3.	Monitoring <i>R. cingulata</i> / <i>R. indifferens</i>	107
G.4.	Conclusions.....	108
6.	CONCLUSIONS	110
7.	RECOMMENDATIONS OF INSECTICIDE-FREE STRATEGIES FOR CONTROLLING <i>R. CERASI</i> ..	118
8.	REGISTER OF FIGURES AND TABLES	120
9.	ACKNOWLEDGEMENTS	122
10.	REFERENCES	123
11.	CURRICULUM VITAE	137
12.	ANNEX	138

1. Summary

The European cherry fruit fly, *Rhagoletis cerasi* Loew (Diptera: Tephritidae), is a highly destructive pest of sweet cherries in Europe. Up to 100% of the fruit can be infested. Methods for controlling this pest are limited in organic agriculture as well as in integrated production, as the insecticide currently used (Dimethoate) is being challenged due to problems of ecotoxicity and residues. Alternative methods for cherry fruit fly management are therefore needed. The aim of this thesis was to develop a new control strategy for *R. cerasi* using entomopathogenic fungi.

In a first step, the effects of six fungus isolates on the mortality of different life stages of *R. cerasi* were assessed in a series of laboratory experiments. All fungus isolates caused mycosis in *R. cerasi* larvae and adults. These results are the first evidence of the susceptibility of *R. cerasi* to infection with hyphomycetous fungi. Because the flies for the laboratory experiments were collected from different locations in northwestern Switzerland, susceptibility to entomopathogenic fungi can be assumed for the cherry fruit fly population in the whole region. Although all fungus isolates tested were pathogenic to adults and larvae, virulence varied considerably among fungus isolates and *R. cerasi* life stages. The effects on L₃ larvae were negligible; none of the fungus isolates induced mortality in more than 25% of the larvae. In contrast, adult flies were found to be highly susceptible to all fungus isolates (*Metarhizium anisopliae* 714, *M. anisopliae* 786, *Isaria fumosorosea* 531, *I. fumosorosea* Apopka 97 and *Beauveria bassiana* ATCC 74040) except *Isaria farinosa* 954. The high mortality of 90 to 100% induced by *B. bassiana* and *I. fumosorosea* during the pre-oviposition period led to significantly reduced oviposition. Higher conidia concentrations generally led to higher mortality. *B. bassiana* was the most effective isolate at low concentrations. Young flies showed lower mortality rates than older flies, but effects on egg eclosion rate were greatest young flies treated zero to one day after emergence. A fly-to-fly conidia transmission could not be proven after treatment of flies with a conidia suspension. Soil treatments with entomopathogenic fungi to infect emerging flies were also effective. Although the adult emergence rate was not reduced, flies emerging from treated soil showed a mortality of 42 to 83%. The oviposition rate was thus reduced by 29 to 73%, depending on the fungus isolate.

In a second step, different field application strategies were considered: soil treatments with entomopathogenic fungi to control emerging adults, the use of auto-inoculative devices for attract-and-kill strategies, and on-plant application as mycoinsecticides. Because the two American cherry fruit fly species *Rhagoletis indifferens* and *Rhagoletis cingulata* were introduced in Europe in the 1980s and because the isolates of entomopathogenic fungi selected for *R. cerasi* might show a different virulence on these species, the field experiments were accompanied by a four-year monitoring campaign for these species. The results of the campaign indicate that the population density of the American species is very low (<0.001%) in commercial sweet cherry orchards in northwestern Switzerland.

Soil treatments with biocontrol agents can only be effective if fly migration between differently treated trees is low. In order to examine the general potential of soil treatments, experiments using netting to cover the soil were conducted in two years and in two different orchards. The netting reduced fruit infestation by 91%. In addition, it was shown that the flies move only very short distances (less than 5 m) within orchards. In general, soil treatments are

considered to be a promising strategy for controlling *R. cerasi*. The efficacy of soil treatments using different formulations of entomopathogenic fungi was evaluated in semi-field trials. Soil treatments with barley grain-formulated entomopathogenic fungi had no effect on fly emergence rate. However, adult mortality was significantly increased. The oviposition rate was thus reduced by up to 90%. In conclusion, the experiments provide first evidence that control of adult *R. cerasi* is possible with soil treatments under field conditions in temperate zones. A further development of this control strategy seems worthwhile for fungus isolates tested, *B. bassiana* and *M. anisopliae*. However, the results of the one year semi-field experiments do not allow general conclusions.

Another approach to bring the flies in contact with entomopathogenic fungi is the use of auto-inoculative devices in an attract-and-kill strategy. For an effective attract-and-kill strategy, however, highly attractive traps and baits are an essential prerequisite. The attractiveness of baits was therefore evaluated using yellow sticky traps in combination with different baits in field experiments in three years and in five different orchards. Although some baits were able to double the number of captured flies, the response of the flies to the various baits was low overall. More effective baits are needed in order for their application to be economical.

On-plant application of mycoinsecticides is another method for exposing the flies to entomopathogenic fungi. Foliar applications of *B. bassiana* (product Naturalis-L) at seven day intervals significantly reduced the number of infested fruit by 60 to 70%. Flight activity monitored by yellow sticky traps was only slightly affected by treatments. Infection of flies under field conditions was shown to be possible. The results were obtained from five experiments in two years with considerably different weather conditions and in different orchards with different flight intensities of *R. cerasi*. The other treatments tested (PreFeRal®WG containing *I. fumosorosea* and extensive application regime of Naturalis-L) were less effective. In order to evaluate a possible repellent effect of formulation additives contained in the oil-based formulation of the product Naturalis-L, laboratory, semi-field and field experiments were conducted using Naturalis-L, additives of Naturalis-L and other oil products. Observations of fly behaviour in the laboratory experiments revealed that oil products had an oviposition deterring effect: flies frequently landed on treated fruit and started their typical oviposition behaviour; however, due to the slippery, oily fruit surface, the flies were not able to penetrate the skin with their ovipositors. The rate of successful oviposition was thus reduced. Under field conditions, however, rape oil products degrade too rapidly to provide good control. For the product Naturalis-L, these results suggest a dual mode of action: (1) some flies are killed due to fungus infection and (2) sub-lethally infected and weakened flies might be overtaxed by the oily film on the fruit surface and therefore unable to oviposit.

In conclusion, the application of Naturalis-L (*B. bassiana*) is a suitable and economically feasible strategy for controlling *R. cerasi*. Naturalis-L is currently registered for cherry fruit fly control in Italy and Switzerland. For good efficacy, four treatments of 0.25% Naturalis-L with 1000 l water per hectare should be applied at seven to ten day intervals beginning five to ten days after the beginning of the flight period until seven days before harvest. In extensively managed standard trees, *R. cerasi* management is still difficult, and Naturalis-L applications are not recommended due to possibly insufficient fruit coverage in the upper canopy. Further research is needed to evaluate whether soil treatments with barley grain-formulated fungi could be a viable strategy for controlling *R. cerasi* in these orchards.

2. Zusammenfassung

Die Kirschfruchtfliege, *Rhagoletis cerasi* Loew (Diptera: Tephritidae), ist der Hauptschädling im europäischen Kirschenanbau. Die Bekämpfungsmöglichkeiten sind jedoch beschränkt. Für den Öko-Anbau stehen bisher keine effizienten Bekämpfungsmethoden zur Verfügung und die integrierte Produktion steht vor dem Problem, dass die gängigen Insektizide (Dimethoate) wegen Rückstands- und Nebenwirkungsproblemen vom Markt genommen werden. Neue Lösungen sind also gefragt! Ziel dieser Arbeit war die Entwicklung einer Bekämpfungsstrategie auf der Basis von entomopathogenen Pilzen.

In einem ersten Schritt wurden mehrere Laborexperimente durchgeführt, um die Wirkung verschiedener Pilzstämme auf verschiedene Lebensstadien von *R. cerasi* zu untersuchen. Dabei erwiesen sich alle geprüften Pilzstämme als pathogen für Larven und Adulte. Diese Ergebnisse sind der erste Nachweis, dass eine Infektion von *R. cerasi* durch Hyphomyceten möglich ist. Obwohl alle Pilzstämme pathogen waren, gab es beträchtliche Unterschiede in der Virulenz, wie auch bezüglich der Anfälligkeit der verschiedenen Lebensstadien von *R. cerasi*. L₃ Larven waren kaum anfällig: nur 25% der Larven starben nach der Infektion. Im Gegensatz dazu erwiesen sich adulte Fliegen als hochanfällig für alle geprüften Pilzstämme (*Metarhizium anisopliae* 714, *M. anisopliae* 786, *Isaria fumosorosea* 531, *I. fumosorosea* Apopka 97 and *Beauveria bassiana* ATCC 74040), außer *Isaria farinosa* 954. Die hohe pilzbedingte Mortalität (90 bis 100%) der Fliegen hatte eine signifikant reduzierte Eiablage zur Folge. Höhere Konidienkonzentrationen führten zu einer höheren Mortalität, wobei *B. bassiana* bei niedrigen Konzentrationen tendenziell am besten wirkte. Bei jüngeren Fliegen wurden geringere Mortalitätsraten beobachtet, als bei älteren. Die Wirkung auf die Eifertilität war jedoch bei jüngeren Fliegen (0-1 Tag alt) am ausgeprägtesten. Bodenbehandlungen gegen schlüpfende Fliegen brachten ebenfalls vielversprechende Ergebnisse: die Mortalität der geschlüpften Fliegen war signifikant erhöht, was zu einer reduzierten Eiablage führte.

In einem zweiten Schritt wurden verschiedene Anwendungsstrategien für den Freiland Einsatz geprüft: Bodenbehandlungen gegen schlüpfende Fliegen, die Anwendung einer Attract&Kill-Strategie, sowie die Behandlung der Bäume mit Pilzsporen. Da neben *R. cerasi* die beiden amerikanischen Kirschfruchtfliegenarten, *Rhagoletis indifferens* und *Rhagoletis cingulata*, in Europa beobachtet wurden und da die selektierten Pilzstämme möglicherweise eine schlechtere Wirkung gegen diese Arten zeigen, wurden die Freilandversuche von einem vierjährigen Überwachungsprogramm für diese Arten begleitet. Bisher ist der Besatz mit amerikanischen Kirschfruchtfliegen in den Obstanlagen der Nordwestschweiz jedoch sehr gering (<0.001%).

Bodenbehandlungen gegen schlüpfende Fliegen können nur erfolgreich sein, wenn die Migration der Kirschfruchtfliegen gering ist. Um die grundsätzliche Wirksamkeit von Bodenbehandlungen zu erfassen, wurden Freilandversuche mit Netzabdeckungen am Boden unter den Kirschbäumen durchgeführt. In beiden Versuchsanlagen, sowie in beiden Versuchsjahren reduzierte die Bodenabdeckung die Flugaktivität signifikant. Zudem zeigte sich, dass die Fliegen innerhalb einer Obstanlage nur sehr kurze Distanzen wandern (<5 m). Der Befall mit Maden wurde durch die Bodenabdeckung um 91% gesenkt. Ausgehend von diesen Resultaten wurde die Wirkung von Bodenbehandlungen mit entomopathogenen Pilzen gegen schlüpfende Fliegen in Halbfreilandversuchen untersucht. Die auf Gerstenkörnern formulier-

ten Pilzstämmen erhöhten die Mortalität der geschlüpften Fliegen, was eine zu 90% reduzierte Eiablagerrate zur Folge hatte. Diese Versuche zeigen zwar erstmals, dass eine Regulierung der Kirschfruchtfliege über Bodenbehandlungen mit entomopathogenen Pilzen unter Freilandbedingungen möglich ist, da die Resultate nur auf einem Versuchsjahr und einem Standort beruhen, sind verallgemeinernde Schlussfolgerungen verfrüht. Eine weitere Prüfung dieser Strategie wäre jedoch lohnend.

Ein weiterer Ansatz, um die Fliegen unter Freilandbedingungen in Kontakt mit den Pilzsporen zu bringen, ist die Anwendung einer Attract&Kill-Strategie. Da für die Anlockung der Fliegen hochattraktive Köder notwendig sind, wurde die Wirkung verschiedener Fallen und Köder über drei Jahre in fünf verschiedenen Versuchsanlagen untersucht. Obwohl einige Köder die Fangzahlen der gelben Leimfallen verdoppeln konnten, ist die Wirkung für einen effizienten Massenfang oder für funktionierendes Attract&Kill-Verfahren zu gering.

Die Behandlung der Bäume mit Sporensuspensionen von entomopathogenen Pilzen ist eine weitere Möglichkeit, um die Fliegen im Freiland zu infizieren. Regelmäßige Spritzungen (alle sieben Tage) von *B. bassiana* (Produkt Naturalis-L) konnten den Befall der Früchte mit Maden um 60 bis 70% reduzieren. Die mit Leimfallen überwachte Flugaktivität ging nach der Behandlung leicht zurück. An den gefangenen Fliegen konnten Pilzinfektionen nachgewiesen werden. Die Versuche in zwei Jahren und in fünf verschiedenen Obstanlagen konnten zeigen, dass diese Wirkung auch unter verschiedenen Wetterbedingungen und bei verschiedenen Befallsstärken der Kirschfruchtfliege gegeben ist. Die anderen geprüften Verfahren (Behandlung mit *I. fumosorosea*, Produkt: PreFeRal®WG, sowie extensive Applikationsstrategie von Naturalis-L) zeigten weniger befriedigende Resultate.

Da die Konidien von *B. bassiana* im Produkt Naturalis-L in einer öligen Formulierung vorliegen, wurden die Nebenwirkungen der Formulierungshilfsstoffe und anderer Ölprodukte auf die Eiablage von *R. cerasi* untersucht. Die Beobachtungen im Labor zeigten, dass Ölprodukte die Eiablage der Fliegen verhindern: Die Fliegen landeten zwar wiederholt auf behandelten Früchten und versuchten Eier zu legen, fanden aber auf der öligen, rutschigen Oberfläche nicht genügend Halt, um mit ihrem Legeapparat die Fruchthaut zu penetrieren. Die Anzahl abgelegter Eier war daher deutlich reduziert. Bei den Halbfreiland- und Freilandversuchen zeigte sich jedoch, dass Ölprodukte auf der Fruchtoberfläche recht schnell abgebaut werden und daher nur sehr kurzzeitig Schutz bieten. Für das Produkt Naturalis-L deuten diese Ergebnisse auf einen dualen Wirkungsmechanismus hin: einerseits werden die Fliegen durch die Pilzinfektion abgetötet, andererseits wird den sublethal geschädigten Individuen die Eiablage durch den Belag auf den Früchten zusätzlich erschwert.

Zusammenfassend kann man sagen, dass mit der Applikation von Naturalis-L (*Beauveria bassiana*) eine wirksame Strategie zur Bekämpfung von *R. cerasi* zur Verfügung steht. Naturalis-L ist seit 2008 für diese Indikation in der Schweiz und Italien zugelassen. Für eine gute Wirkung gegen die Kirschfruchtfliege, sollte Naturalis-L beginnend fünf bis zehn Tage nach Flugbeginn bis sieben Tage vor der Ernte in 7-tägigen Abstand mit einer Konzentration von 0.25% (1000 l Wasser pro Hektar) appliziert werden. Bei Hochstammbäumen, wo eine gute Benetzung der oberen Baumkrone bei der Spritzung oft nicht möglich ist, bleibt die Bekämpfung der Kirschfruchtfliege jedoch weiterhin schwierig. Um auch für diese Situationen eine Lösung zu finden, sind weitere Versuche zur Bodenbehandlung mit entomopathogenen Pilzen gegen schlüpfende Fliegen notwendig.

3. Introduction

The European cherry fruit fly, *Rhagoletis cerasi* Loew (Diptera: Tephritidae), is a highly destructive pest of sweet cherries in Europe. Up to 100% of the fruit can be infested without insecticide treatment (Fischer-Colbrie & Bush-Petersen, 1989). Although *R. cerasi* has been known as a pest for a long time – it was first mentioned in 1540 (Kobel, 1933) – and although it has been well studied (Frank, 1891; Ménegaux, 1898; Berlese, 1906; Verguin, 1928; Jancke & Böhmel, 1933; Wiesmann, 1933b; Thiem, 1934; Wiesmann, 1934b; Wiesmann, 1936; Boller, 1966b; Boller, 1966a; Boller & Prokopy, 1976; Engel, 1976; Katsoyannos, 1976; Katsoyannos et al., 1986; Katsoyannos et al., 1987; Ranner, 1988b; Aluja & Boller, 1992; Raptopoulos et al., 1995; Riegler & Stauffer, 2002), it still poses a challenge to cherry growers because of the low market tolerance for damaged fruit. In cherries for fresh consumption, a maximum of 2% infested fruit is tolerated. For the canning industry, infestation levels below 6% are required. Because the infested fruit cannot be sorted out, the whole lot will be rejected if requirements are not met. The disqualification of table and cannery cherries to distillery quality considerably reduces the market price, which causes serious financial losses. This low tolerance level is the principal reason for preventive insecticide treatments. The phase-out of “old” insecticides now threatens cherry production throughout the European Union. The current use of the insecticide Dimethoate in particular is being challenged due to problems of ecotoxicity and residues. Yellow sticky traps are currently used in organic cherry production. However, this strategy is labour-intensive and often does not provide sufficient control. Alternatives for cherry fruit fly management are therefore needed in integrated fruit production as well as in organic farming.

4. Objectives and structure of the thesis

The aim of this thesis was to develop a new control strategy for *R. cerasi* using entomopathogenic fungi.

In a first step, different isolates of entomopathogenic fungi were screened in laboratory experiments in order to find suitable isolates for field application. Details on this first step are given in **part A**.

In a second step, different field application strategies were considered: Soil treatments with entomopathogenic fungi to control larvae before pupation or emerging adults, the use of auto-inoculative devices for attract-and-kill strategies, and on-plant application as mycoinsecticides.

Details for laboratory experiments on soil treatments with entomopathogenic fungi are also given in **part A**. However, soil treatments with biocontrol agents can only be effective if the migration of flies between differently-treated trees is low. In order to evaluate the dispersal and flight behaviour of *R. cerasi* within orchards and to examine the general potential of soil treatments, experiments using netting to cover the soil were conducted in two orchards. Details of these experiments are given in **part B**. The efficacy of soil treatments using different formulations of entomopathogenic fungi was evaluated in semi-field trials. Details of these experiments are given in **part C**.

An essential prerequisite for attract-and-kill strategies are highly attractive traps and baits. The efficacy of different traps and baits was therefore evaluated in field experiments. Details are given in **part D**.

The on-plant application of two mycoinsecticides containing entomopathogenic fungi (Naturalis-L and PreFeRal®WG) was tested in five field experiments. The details of two years of experiments are given in **part E**. In order to evaluate a possible repellent effect of formulation additives contained in the oil-based formulation of the product Naturalis-L, laboratory, semi-field and field experiments were conducted using Naturalis-L, additives of Naturalis-L and other oil products. Details are given in **part F**.

The two American cherry fruit fly species *R. indifferens* and *R. cingulata* were introduced in Europe in the 1980s. Because the isolates of entomopathogenic fungi selected for *R. cerasi* might show a different virulence on these species, it is important to determine the population densities of this species in commercial cherry orchards. Results of a four-year monitoring in northwestern Switzerland are given in **part G**.

The two last chapters of this thesis summarize the findings, relate this study with other research on *R. cerasi*, present current possibilities and costs for controlling *R. cerasi*, show the needs for further research and give recommendations for insecticide-free strategies for cherry fruit fly control.

5. Biology of *R. cerasi*

5.1. Taxonomy, geographic distribution and host plants

The Tephritidae are an insect family distributed world-wide with about 4000 described species in about 500 genera (Headrick & Goeden, 1998). The family is divided into two major sub-groups: frugivorous and non-frugivorous Tephritid flies, based on food type explored for larval development. Species of the first group use the pulp of fleshy fruits for larval development, whereas species of the second group feed in living plant tissues such as stems, roots, leaves, or seeds and often form galls. Some of these species living in flower heads of Asteraceae (Headrick & Goeden, 1998) show potential as biological control agents of weeds (Zwölfer, 1983).

The frugivorous fruit flies can be further divided into two sub-groups: univoltine, oligophagous species with a long winter diapause from temperate zones (i.e. *Rhagoletis* sp.) and multivoltine, polyphagous species without obligatory diapause from warmer regions (i.e. *Bactrocera* sp. and *Anastrepha* sp.) (Bateman, 1972). Mating systems, host finding behaviour, dispersal flight activity, attraction to food baits or host plant odours differ greatly between these two groups.

“Life history characteristics of polyphagous species are best suited for exploiting resources that occur intermittently throughout most of the year but are unpredictable in time and space: the adults have a high mobility, a relatively long life span (> three months), a high potential fecundity (>1000 eggs per female) and scramble type competition in the larval stages, several generations per year and the ability to pass unfavourable periods of the year in a facultative reproductive diapause when necessary” (Fletcher, 1987). The mating system of these species is usually lek-based with a long range pheromone and a complex courtship behaviour including acoustical, optical and olfactory cues (Sivinski & Burk, 1989).

In contrast, life history characteristics of oligophagous species are best suited for exploiting resources that are predictable in time and space but are only available during a short period of the year. A close adaptation of their biology to the fruiting pattern of the host and precision in seasonal synchronisation are more important than high reproductive potential and high mobility (Zwölfer, 1983). Hibernation occurs in the soil in the immediate vicinity of the hosts. There is thus no need for dispersal flights. Adult emergence and life span are closely correlated with host plant phenology (Boller & Prokopy, 1976). Pupal carryover for two or more winters is used for “spreading the risk” of failure of the host plants to fruit in a particular year (Zwölfer, 1983). There is usually only one generation each year and a long obligatory winter diapause (Bateman, 1972). Fecundity (300 to 400 eggs per female) is considered to be lower than in the polyvoltine species (Boller & Prokopy, 1976). Relatively unspecific visual and odour stimuli are used to identify oviposition sites. Competition in the larval stages (contest type) is largely avoided by oviposition of only a single egg in each fruit and by the application of a host marking pheromone after oviposition, which ensures an adjustment of larval density to the carrying capacity of the host and maximizes dispersion over available food resources (Fletcher, 1989a). The mating system of these species is usually resource-based: the males control the oviposition substrates and mating is often initiated by forced copulation without elaborate courtship behaviour (Sivinski & Burk, 1989).

The genus *Rhagoletis* Loew includes about 65 known species and some as yet undescribed species distributed throughout Europe, Asia and America (White & Elson-Harris, 1992). Most species are oligophagous, attacking only a few closely related host plants. In addition to *R. cerasi*, the American cherry fruit fly species *R. cingulata*, *R. indifferens* and *R. fausta*, as well as the apple maggot *R. pomonella*, the blueberry maggot *R. mendax*, and the walnut infesting species *R. completa* and *R. suavis* are pest insects of economic importance (Boller & Prokopy, 1976).

The European cherry fruit fly, *R. cerasi* Loew, has also been known as *Musca cerasi* L., *R. cerasorum* (Dufour), *R. liturata* (Robineau-Desvoidy), *R. signata* (Meigen), *Spilographa cerasi* L., *Trypeta signata* (Meigen), *Urophora cerasorum* Dufour und *U. liturata* Robineau-Desvoidy (Frank, 1891; White & Elson-Harris, 1992).

R. cerasi is distributed throughout Europe and temperate regions of Asia (White & Elson-Harris, 1992; Jaastad, 1994). There are two races, which are referred to as the northern and southern races. The southern race is found in Italy, Switzerland and southern Germany, whereas the northern race ranges from the Atlantic Ocean to the Black Sea (White & Elson-Harris, 1992). Between the two races, there is a unidirectional cytoplasmic incompatibility caused by maternally-inherited *Wolbachia* infections: as a consequence, southern females and northern males are interfertile, but crosses between southern males and northern females are sterile (Boller et al., 1976; Matolin, 1976; Ranner, 1988b; Boller, 1989a; Blümel et al., 1991; Riegler, 2002; Riegler & Stauffer, 2002).

Host plants of *R. cerasi* include various different *Prunus* sp. (Rosaceae; *P. cerasus*, *P. avium*, *P. serotina*, *P. mahaleb*) (Thiem, 1934; Leski, 1963) as well as *Lonicera* sp. (Caprifoliaceae; *L. xylosteum* and *L. tartarica*) (Mik, 1898; Thiem, 1932; Wiesmann, 1938; Thiem, 1939; Ranner, 1987a; White & Elson-Harris, 1992). The phenology of *R. cerasi* differs among populations associated with cherry and *Lonicera*. The *Lonicera* population is either a well-differentiated host race or possibly a distinct species (Wiesmann, 1935b; Thiem, 1939; Boller & Bush, 1974; Haisch & Forster, 1975; Katsoyannos et al., 1986; Ranner, 1988b; Bush, 1992; Hoffmeister, 1992a; Boller et al., 1998; Schwarz et al., 2003). *Rhagoletis* is one of the few genera in which host shifts and formation of new host races are well documented (Zwölfer, 1983).

5.2. Adult emergence

Pupal development in the spring is mainly influenced by soil temperature. Timing of adult emergence is therefore affected by altitude, latitude, slope, soil type, soil cover and other environmental factors (Thiem, 1934; Wiesmann, 1934b; Leski, 1963; Kovanci & Kovanci, 2006). In addition, timing of emergence is influenced by the host plants from which the pupae originated (Thiem, 1940; Boller & Bush, 1974; Haisch & Forster, 1975; Ranner, 1988a) and geographic provenance (Baker & Miller, 1978), as well as by temperature conditions during winter diapause (Wiesmann, 1950; Haisch, 1975; Haisch & Chwala, 1979). A few days before emergence, the pupae turn from yellow to green in colour (Seifert, 1961). The earliest attempts to develop a forecasting model for the eclosion time of flies were made in the 1930s (Jancke & Böhmel, 1933; Wiesmann, 1933b; Thiem, 1935): According to Wiesmann (1933b), emergence starts at 195 degree days above the temperature threshold of 10°C based on soil temperatures at a depth of 4 cm. Boller (1964; 1966c) revised this model using the

temperature threshold of 5°C and 430 degree days based on soil temperatures measurements at a depth of 5 cm. Leski (1963) used a threshold of 7°C and 320 degree days to predict first emergence and stated that a precise prediction of emergence is impossible solely on the basis of temperature during post-diapause development without taking the conditions and duration of the entire diapause period under consideration. A similar observation was made by Haisch (1975). Baker & Miller (1978) compared the temperature requirements of four different populations from Italy, Austria, Switzerland, and Slovakia. Based on their laboratory experiments, they concluded that the 5°C threshold is too low. They used a threshold of 6.8°C. Pupae from Slovakia and Switzerland showed lower thermal requirements until 10% emergence (319 degree days and 321 degree days, respectively) than pupae from Austria (331 degree days) or Italy (359 degree days). In their field experiments, however, Baker & Miller (1978) found that Boller's model (5°C, 430 degree days) led to the same results as their model (6.8°C, 321 degree days).

Adult emergence often starts after a rainy period when the soil can be easily penetrated (Wiesmann, 1933b), occurs mainly on sunny days (Jancke & Böhm, 1933), and primarily in the late morning hours (Thiem, 1935; Baker & Miller, 1978). Emergence of females starts a few days earlier than emergence of males (Wiesmann, 1933b; Thiem, 1935; Speyer, 1941; Haisch & Forster, 1975). According to Fletcher (1989c), the males require 10 to 25 more degree days than females. Under field conditions, the period of adult emergence lasts from 12 to 23 days (Jancke & Böhm, 1933; Thiem, 1935), with populations from cherries having a narrower emergence period than populations from *Lonicera sp.* (Jancke & Böhm, 1933; Ranner, 1988a). In addition, the emergence rate of pupae from cherries is considered to be higher than the emergence rate of pupae from *Lonicera sp.* (Ranner, 1988a). Emergence rate is also influenced by soil type and is lower in heavy soils than in sandy soils (Thiem, 1940).

When it is ready to emerge, the young adult fly expands its ptilinum (Figure 1) to burst open the end of the puparium. Propellant action through the soils is achieved by inflation and contraction of the ptilinum (Wiesmann, 1934b). After emergence, the adults climb on blades of grass until their wings unfold and dry. The flies are capable of flight within five to 10 hours (Wiesmann, 1933b) and after some uptake of water (Wiesmann, 1934b). In Switzerland, Austria and southern Germany, the first flies usually appear in the orchards between mid-May and mid-June (Böhm, 1949). Adult emergence is closely timed with host plant fruiting phenology.

Adult flies have a bright black thorax, a yellow scutellum and a characteristic wing pattern (Figure 1). The size of adults can vary, depending on host quality during larval development. On average, females reach a size of 5 mm and males are slightly smaller (4 mm) (Samoggia, 1932; Wiesmann, 1933b; Leski, 1963). The sex ratio is more or less equal: Boller (1966b) and Prokopy (1969) mention a proportion of 50% females, other authors observed slightly more females than males: 52% females (Speyer, 1941), 54% females (Haisch, 1975) and 60% females (Haisch & Forster, 1975), respectively. Thiem (1935) observed more males than females (45% females).



Figure 1: The European cherry fruit fly: newly emerged female with ptilinum (left), female (middle) and male (right).

5.3. *Pre-oviposition period*

Before oviposition, the adults go through a maturation period during which they need to feed on carbohydrates, proteins and water in order for the gonads to mature. The search for food is not necessarily confined to the larval host plant. Nutrients are obtained from bird faeces, honeydew, extrafloral nectaries, and bacterial colonies on leaf and fruit surfaces (Verguin, 1927; Verguin, 1928; Samoggia, 1932; Sprengel, 1932b; Wiesmann, 1933b; Wiesmann, 1944). Feeding normally occurs in the morning, but some feeding may take place at other times (Haisch & Forster, 1975). Flies rest on the undersides of leaves during the night and during periods of daytime inactivity (Haisch & Forster, 1975).

The duration of the pre-oviposition period is strongly influenced by temperature and ranges from six to 13 days (Berlese, 1906; Sprengel, 1932a; Wiesmann, 1934a; Wiesmann, 1935b; Böhm, 1949; Leski, 1963): At 23°C and 18°C, Boller (1966a) observed pre-oviposition periods of six and 10 days, respectively. However, Remund & Boller (1971) compared the data given in the literature and concluded that temperature-based forecasting models are invalid for predicting first oviposition under field conditions, because the beginning of oviposition is delayed in some years. The nutritional status of the flies can have a pronounced effect on the duration of the pre-oviposition period: under unfavourable alimentary conditions, Thiem (1935) observed that 33% of females did not carry mature eggs 17 days after emergence. In addition to the temperature and nutritional status of the females, the maturity stage of the cherries can also affect the beginning of oviposition: eggs are only deposited in fruits at the stage of colour change from green to yellow, with a hardened cherry pit, and pulp at least 5 mm thick (Sprengel, 1932a).

The food type, the size of the fly, and fly density influence life expectancy under laboratory conditions. However, laboratory observations of life spans more than 100 days (Ranner, 1988b) might be biased, because negative effects of unfavourable climatic conditions (rain) are not taken into account. The life span of flies under field conditions is difficult to estimate and may range between four to seven weeks (Samoggia, 1932; Sprengel, 1932a;

Wiesmann, 1933b; Böhm, 1949), which leads to a total flight period of seven to 11 weeks (Jancke & Böhmel, 1933; Böhm, 1949; Stamenkovic et al., 1996a).

5.4. Mating

Male flies are capable of copulation immediately after emergence, whereas females start mating at an age of three to four days (Leski, 1963; Katsoyannos, 1979). Mating (Figure 2) occurs around noon on sunny days with temperatures above 15°C (Wiesmann, 1933b; Katsoyannos, 1979). Host fruit on sunny parts of the trees are used as a mating site.



Figure 2: Mating of *R. cerasi*.

Mating is initiated when a female in search of an oviposition site lands on a fruit occupied by a male (Katsoyannos, 1979). Males mount by a jump or a short flight onto the female's abdomen. Copulation lasts between 20 minutes and one hour (Verguin, 1928; Katsoyannos, 1976). Males can mate frequently, whereas females become sexually unreceptive for several weeks after mating (Katsoyannos, 1982). A single copulation, however, was found to be insufficient for fertilizing the whole stock of eggs (Boller, 1966a). One to three copulations during a female's life span are considered to be necessary (Wiesmann, 1933b).

It was shown that the males produce a highly species-specific pheromone which attracts females (Katsoyannos, 1976; Hoffmeister, 1992a; Raptopoulos et al., 1995). The strongest reaction of females was observed between the seventh and ninth hour of an 18 h photoperiod, which would be around noon under field conditions (Katsoyannos, 1982; Katsoyannos, 1989a). In laboratory experiments, however, only 30% of virgin females were found to be responsive to male-emitted odours (Katsoyannos, 1979). In field cage (Hoffmeister, 1992a) and in field experiments (Katsoyannos, 1982), only 10% and 20%, respectively, of the released females were recaptured by male-baited traps. Katsoyannos (1979) observed that females were attracted from a distance of 10 m under field conditions. Hoffmeister (1992a), however, concluded that the pheromone does not have a long-range attraction. Katsoyannos (1982) concluded that besides the pheromone, fly behaviour plays a major role in locating mating partners: due to their preference for host fruits in full sun, the flies aggregate in certain parts of the trees. In these circumstances, an elaborate long-range pheromone might be of minor importance. Boller & Prokopy (1976) hypothesized that the pheromone might function primarily as an aphrodisiac, whereas Raptopoulos et al. (1995)

were able to show “two distinct groups of compounds: those acting as attractants, attracting large numbers of females and the second, acting as arrestants stimulating incoming individuals to stay for a long time on the area of stimulus”. Jaastad (1998) observed a non-random distribution of matings among males and concluded that there might be a female choice involved in the mating system of *R. cerasi*. At the present time, however, no other attractive sex pheromones nor any acoustic signals have been described for *R. cerasi*.

5.5. Oviposition

Oviposition occurs around noon and during early afternoon (Katsoyannos et al., 1987) on sunny days when temperatures rise above 16°C (Wiesmann, 1933b; Thiem, 1940; Böhm, 1949; Boller, 1966a). Oviposition activity is considerably reduced on overcast days (Boller, 1966a; Boller, 1968). Relative humidity has no effect on oviposition (Boller, 1966a). Rain (Wiesmann, 1934b) and a wet fruit surface (Prokopy & Boller, 1971b), however, completely prevent oviposition activity. Although direct insolation stimulates oviposition, the flies choose shady places to oviposit: oviposition punctures are usually found near the bottom of the fruit (Boller, 1966a). Weather conditions during the oviposition period are considered to be crucial for the regulation of population densities: the high oviposition activity during long-lasting periods of fine weather can lead to extreme outbreaks of this pest (Thiem, 1935).

Both olfactory and visual cues are involved in the choice of suitable fruits for oviposition. However, the visual component appears to dominate. Females recognize the fruit by visual cues based on shape (spherical or hemispherical), size (2.5 to 10.3 mm diameter) and contrast-colour against the background (dark shape in front of lighter background) (Wiesmann, 1937b; Boller, 1968; Prokopy, 1969; Boller & Prokopy, 1976). Once a suitable fruit has been located, the female explores the surface structure (smoothness, softness and shape) by walking in circles on the surface and decides whether or not to oviposit (Wiesmann, 1937b; Boller, 1989b). During this exploration, the condition and the chemistry of a fruit might influence oviposition behaviour. However, volatile odours of the oviposition site do not appear to be important in eliciting oviposition (Prokopy & Boller, 1971b; Guerin et al., 1983), as females readily oviposit into inanimate objects (Prokopy & Boller, 1969) or fruits in which the larvae cannot complete their development (Thiem, 1935; Wiesmann, 1937b). In wax domes with treated surfaces, however, fruit odours of two host species stimulated oviposition, whereas fruit odours of non-host species discouraged – but did not completely prevent – oviposition (Haisch & Levinson, 1980; Levinson & Haisch, 1984; Karrer et al., 1990).

Cherries at the stage of colour change from green to yellow, with a hardened cherry pit, and pulp at least 5 mm thick are preferred for oviposition (Sprengel & Sonntag, 1932). The female pierces the fruit with its ovipositor and inserts a single egg just below the skin (Häfliger, 1953). Oviposition duration varies from 0.5 to five minutes, depending on fruit maturity (skin or flesh hardness) (Wiesmann, 1937b). Very little is known about the physical forces needed by the fly to penetrate the skin. After oviposition the females deposit a water-soluble host-marking pheromone by dragging the ovipositor around the fruit surface (Thiem, 1934; Katsoyannos, 1975; Katsoyannos, 1979). This pheromone prevents further ovipositions into the same fruit (Hurter et al., 1989; Aluja & Boller, 1992; Boller & Aluja, 1992). Under field conditions with high infestation levels, however, multilarval infestations are

frequently observed, which suggest multiple ovipositions into the same fruit (Fimiani, 1983; Fimiani, 1984; Dederichs, 2003).

Under field conditions, fecundity is thought to range from 30 eggs (Leski, 1963), 50 eggs (Jancke & Böhm, 1933; Wiesmann, 1934a; Böhm, 1949), to as many as 100 eggs per female (Wiesmann, 1933b). However, according to observed infestation rates and observed numbers of flies per tree, Boller (1966a) believes that the estimated fecundity of 50 to 100 eggs per female is too low. A maximum fecundity of 469 eggs per female (average: 200 eggs per female) was observed in the laboratory, and oviposition rates of up to 59 eggs per female per day (average: 26 eggs per female per day) were recorded (Boller, 1966a). Fecundity seems to depend mainly on the life span of females: highest oviposition activity is observed 10 to 25 days after emergence (Wiesmann, 1933b; Katsoyannos et al., 1987). However, even 49 day old females were still found ready to oviposit in laboratory experiments (Katsoyannos et al., 1987).

The elongated, elliptical and slightly curved, white eggs have an approximate length of 0.75 mm and a diameter of 0.25 mm (Samoggia, 1932; Wiesmann, 1933b). Fertility ranges between 54 and 100% (Boller, 1966b; Boller, 1966a). A reduced fertility is mainly observed during prolonged periods of fine weather when copulation is reduced in favour of oviposition or after oviposition in unripe cherries (Boller, 1966b). The duration of embryonic development mainly depends on temperature. According to data cited in the literature, it ranges from two days (Sprengel & Sonntag, 1932), six days (Verguin, 1928), to as long as 10 days (Wiesmann, 1933b; Leski, 1963). Thiem (Thiem, 1935) noted that embryonic development might even be longer than 10 days in unripe fruits.

5.6. Dispersion

With the relative stability of the system, i.e. pests that overwinter beneath perennial hosts, there appears to be little impetus for adults to move long distances. In environments in which oviposition substrates are plentiful, adults tend to remain within a close range, their movements are associated with normal activities of feeding, ovipositing and mating (Wiesmann, 1933b; Katsoyannos et al., 1986). These movements show a daily periodicity and rarely take individuals far from their host plants (Haisch et al., 1976; Katsoyannos et al., 1986). Flight activity also depends on climatic conditions: highest activity is observed on warm, sunny days with low relative humidity (Sprengel & Sonntag, 1932). On rainy days, most of the flies hide in the sward under the trees. Only a few individuals remain in sheltered places within the tree canopy (Wiesmann, 1934b).

Dispersal flights occur only in situations in which flies are deprived of suitable fruits for oviposition: when cherries are destroyed by frost or early harvest or when all fruits are already marked with the host-marking pheromone (Katsoyannos et al., 1986). Driven by high oviposition pressure, the females leave their original tree (Wiesmann, 1934b), and the males follow a little later (Wiesmann, 1933b; Katsoyannos et al., 1986). The flies move from tree to tree until they find a suitable host (Wiesmann, 1935b).

Orientation during dispersal flight is mainly based on visual stimuli. Foliage colour, tree shape and tree size play a role in eliciting the arrival of flies. *R. cerasi* is known to be highly responsive to visual stimuli (Prokopy, 1969), especially to yellow surfaces (Boller, 1969; Haisch & Forster, 1969; Haisch & Forster, 1970; Remund, 1971; Katsoyannos, 1989b).

Prokopy (1971) suggested that large yellow surfaces represent a super-normal foliage-type stimulus that elicits food-seeking behaviour in *R. cerasi*. He also argued that flies react to yellow on the basis of true colour discrimination. This view was supported by Agee et al. (1982), who showed that adult *R. cerasi* have a major peak of electroretinographically assessed spectral sensitivity at 485 to 500 nm (yellow green region) and a secondary peak at 365 nm (ultraviolet region). Coloured surfaces with a sharp increase of reflectance in the 500 to 520 nm region were found to be most attractive to *R. cerasi* (Prokopy & Boller, 1971a; Agee et al., 1982). In addition to flat yellow surfaces, Prokopy (1971) showed that *Rhagoletis* flies also react to red or dark coloured spheres of approximately the same size as the host fruit (Haisch & Forster, 1970; Katsoyannos, 1989b). Attraction of fruit flies to spherical objects is believed to represent a response to mating and oviposition site stimuli. However, none of these cues are host-specific. Boller (1969) believes that the flies are not able to distinguish between host and non-host trees at greater distances, whereas Katsoyannos et al. (1986) believes that females can identify trees with fruits at the right ripening stage from a certain distance. However, once the flies arrive at a host tree, they might be able to identify host-specific leaf stimuli with their tarsal contact chemoreceptors (Städler & Schöni, 1991).

Maximum distances of dispersal flights are difficult to evaluate experimentally: Leski (1963) and Wiesmann (1935b) mention migrations of 350 m and 300 m, respectively. In mark-release-recapture experiments, 82% of the flies were recaptured within a distance of 100 m; only 0.7% of the flies were recaptured at a distance of 500 m (Boller, 1969). Flight studies in the laboratory, however, showed that flies are capable of flying several kilometres in 24 hours if no landing platforms were available (Remund & Boller, 1975). Although such distances might never be flown in nature, the data indicate that flies can easily cross open fields without attractive silhouettes of trees (Boller, 1969). Within orchards, flies generally move only to neighbouring trees of later ripening varieties (Leski, 1963), and from there on to *Lonicera* sp. bushes (Katsoyannos et al., 1986).

5.7. Larval development

Neonate larvae, which are approximately 0.6 mm in size (Samoggia, 1932; Haisch et al., 1978), immediately move towards the cherry pit in order to find protection from parasitoids and predators (Wiesmann, 1934a). A detailed morphological description of the larvae is given by Mik (1898), Samoggia (1932) and Wiesmann (1933b). Larval development lasts between 17 (Thiem, 1935; Leski, 1963) and 30 days (Verguin, 1928), depending on the temperature and the maturity stage of the cherries. The larvae go through three instars, reaching a final size of approximately 6 mm (Haisch et al., 1978). During their development, the larvae tunnel in the fruit, macerate the tissue and ingest the broken down pulp (Verguin, 1928; Wiesmann, 1933b). Infested fruit appear normal until the larvae are nearly fully grown. Larval feeding inside the fruit causes the pit to separate from the pulp and causes the pulp to turn brown and rot (Figure 3). The sugar content and acidity of the fruit flesh influence larval growth and the duration of larval development. Larvae develop better and faster in fruits with higher sugar content and lower acidity (Boller, 1966b). High populations of *R. cerasi* can be therefore observed in sweet cherry orchards, whereas sour cherries usually remain free from high infestations (Fimiani et al., 1981; Stamenkovic et al., 1996b; Balazs & Jenser, 2004).



Figure 3: Infested cherries.

5.8. *Pupation and diapause*

Around harvest (Wiesmann, 1934a), mature larvae bore exit holes through the fruit skin (Figure 4), usually close to the fruit stem (Sprengel, 1932c; Wiesmann, 1933b). Rising temperature in the pulp in the morning is the main stimulus for the larvae to leave the fruit (Boller, 1966b). Therefore, most larvae drop to the soil between 11 am and 1 pm on sunny days (Boller, 1966b). Pupating larvae are highly susceptible to predators and desiccation. The synchronisation of pupation might help in avoiding predators. In addition, pupation in the morning ensures that the larvae are not exposed to extreme heat and dryness (Boller, 1966b).



Figure 4: Damaged cherries with exit holes of larvae.

Larvae exhibit a marked geotropism, disappearing into the soil within one to three minutes after leaving the fruit (Wiesmann, 1950). Under field conditions, pupation usually occurs within three hours after entering the soil (Wiesmann, 1933b). Most pupae are therefore found directly under the tree canopy, especially under the south and southeast parts of the tree, which is also where the highest fruit infestation levels are observed (Engel, 1969). Pupation depth is mainly influenced by soil type and usually ranges from 2 to 5 cm (Ménegaux, 1898;

Wiesmann, 1934a; Leski, 1963; Engel, 1976). Dry, sandy soils with a rough surface structure are most suitable for pupation and overwintering (Karsch, 1889; Sprengel, 1932a; Thiem, 1934). Larvae cannot penetrate compacted soil (Wiesmann, 1933b). The pupae remain in an undeveloped histological stage until the following spring (Wiesmann, 1950). The puparium (Figure 5) is straw-yellow in colour, cylindrical, up to 4 mm long and 2 mm in diameter (Mik, 1898; Samoggia, 1932; Wiesmann, 1933b). Female pupae tend to be bigger than male pupae (Remund & Boller, 1976; Ranner, 1987b).



Figure 5: Pupae of *R. cerasi*.

The cherry fruit fly is an univoltine species: the pupae remain in the soil until the following spring. Overwintering pupae enter diapause and require a chilling period before development can continue. Approximately 180 days at temperatures below 5°C are required for maximum emergence (Thiem, 1934; Leski, 1963; Haisch, 1975; Haisch & Forster, 1975). Under field conditions in Switzerland, 20% of the pupae had already ended diapause by the end of December, 50% of pupae were ready for emergence in January, and emergence rate reached 100% in March (Wiesmann, 1950). Winter temperatures do not have a marked effect on population dynamics, as the pupae are adapted to a wide range of temperatures (Leski, 1963; Neuenschwander et al., 1983). Pupal mortality during the nine to 10 months of diapause is high and is mainly attributed to unfavourable climatic conditions: usually only 5% (Herz et al., 2007) to 15% (Boller, 1966b) of the pupae emerge in the following year. Emergence is reduced in wet, clay soils (Thiem, 1940; Boller, 1966b).

A few individuals remain in diapause for an additional year or sometimes for several years (Wiesmann, 1933b; Thiem, 1934; Wiesmann, 1934b; Thiem, 1935; Speyer, 1941). This pupal carryover is a highly adaptive trait, ensuring that the population will not perish on account of failure of host plants to fruit in some years. However, data on the percentage of pupae diapausing for more than one year show wide ranges: from 1 to 21% (Engel, 1976), 10% (Wiesmann, 1933b; Speyer, 1941; Leski, 1963), 7 to 21% (Wiesmann, 1934b), 47% (Thiem, 1935) and 25 to 100% (Sajo, 1902b). A higher percentage remains in diapause for an additional year in heavy clay soils than in sandy soils (Wiesmann, 1934b). In my laboratory experiments, only one to 3% of the pupae remained in diapause for more than one year after an optimal cold storage (180 days at 4°C).

5.9. Population dynamics and abiotic mortality factors

Many factors (biotic and abiotic) can influence the dynamics of cherry fruit fly populations by directly or indirectly affecting survival and development rates or female fecundity. The most important factors are climatic conditions and host availability. Cherry fruit fly infestations are rarely observed at altitudes above 800 m (Boller, 1966b; Engel, 1976).

The mortality within one generation can reach 99.6% (Boller, 1966b). However, only a few exact studies evaluate the causes of mortality (Boller & Remund, 1989). The basic demographic parameters have been determined by Boller (1966b). In cherry production, harvest (and the consequent removal of larvae from the orchard) is considered to be the main mortality factor (Boller, 1966b). In addition, temperature and rain have a major impact on mortality.

Egg and larval stages are well protected inside the cherry. Mortality is generally low during the egg stage (Boller, 1966b). Hatch rate may be reduced when females oviposit in unripe cherries (Boller, 1966b). In addition, some cherry varieties (Schattenmorelle) are known to produce a hard tissue to seclude the eggs (Thiem, 1954). Destruction of cherries by fungal diseases can also lead to increased egg and larval mortality. The first serious cherry fruit fly infestation was observed in Switzerland between 1930 and 1937 – it started only three years after a routine treatment of shothole disease (*Stigmia carpophila*) was introduced: regular yields also lead to improved life conditions for cherry fruit flies (Meier, 1932; Wiesmann, 1943).

Different degrees of infestation are due to phenological differences among cherry varieties and weather conditions during oviposition: early ripening varieties show lower infestation levels because the fruits are harvested before the first flies are ready to oviposit (Verguin, 1928; Jancke & Böhmel, 1933; Böhm, 1949; Stamenkovic et al., 1996b). Generally, the later a cherry variety is harvested, the higher the potential infestation level (Leski, 1963; Stamenkovic et al., 1996b). Sunny conditions during oviposition lead to high infestation levels (Ménégaux, 1898; Thiem, 1935). Rainy conditions during early ripening stages prevent oviposition and mating (Ménégaux, 1898; Wiesmann, 1933b; Wiesmann, 1934b; Prokopy & Boller, 1971b; Katsoyannos, 1979) and might lead to a decay of fruits causing first and second instar larvae to die (Wiesmann, 1943). However, rainy conditions during harvest which cause the cherries to crack and the farmers to leave the trees unpicked, might increase the infestation level the following year (Leski, 1963). Differences in sugar content and acidity of cherry varieties lead to differences in larval nutrition and consequently to differences in fecundity of emerging females (Boller, 1966b). Females from sweet cherry orchards therefore usually show a higher fecundity than females from sour cherry orchards.

The life stages most exposed to climatic conditions and natural enemies are those associated with the soil: mature larvae, pupae and emerging adults. Boller (1966b) compared the number of larvae dropping from the fruit with the number of pupae in the soil and noted that 35 to 63% of the larvae were not able to pupate because of arid soil conditions and predation. He also monitored the number of pupae in the soil and observed a decline in numbers of pupae during the summer (July, August, September) and during the following spring, which he attributed to parasitoid, predator and disease activity. During emergence, flies are also exposed to different enemies: Boller (1966b) observed that only 7 to 50% of pupae in the soil during spring produced adult flies. A similar observation was made by Engel

(1976): The average number of 147 flies per tree evaluated by treatments with a knock-down insecticide was not consistent with the average number of 9000 pupae under each tree.

5.10. Antagonists of *R. cerasi* and other Tephritidae

Viruses

No literature is available on the effects of viruses on *R. cerasi*. For other Tephritid flies (Diptera: Tephritidae), picornaviruses have been described in *Ceratitis capitata* Wied. (Plus & Cavalloro, 1983) and in *Bactrocera tryoni* (Frogatt) (Bashiruddin et al., 1988). Symptoms mentioned for adult *B. tryoni* are: mortality rates of 40 to 50% in the second and third week after emergence and reduced egg-laying for a few days (Moussa, 1978). In addition, reoviruses are known for *Bactrocera oleae* Gmelin (Manousis & Moore, 1989; Anagnou-Veroniki et al., 1997) and *C. capitata* (Plus, 1989). Anagnou-Veroniki et al. (1997) observed large quantities of virions in faeces of adult flies, which might “contribute to the spreading of the virus both horizontally and vertically by contamination of the larval food and eggs during oviposition in olive.” However, the impact of the virus under natural conditions remains unknown (Anagnou-Veroniki et al., 1997). No field application strategy has yet been developed for controlling Tephritid flies with viruses.

Bacteria

Only few references are available on the use of bacteria to control Tephritid flies, and no references are available for *R. cerasi*. Different isolates of *Bacillus thuringiensis* were screened against larvae and adults of *B. oleae* (Alberola et al., 1999) and *Anastrepha ludens* Loew (Robacker et al., 1996; Martinez et al., 1997). Endotoxins of different *B. thuringiensis* isolates were tested against adult *C. capitata* (Gingrich, 1987) and L₃ larvae of *Anastrepha* sp. (Toledo, 1999). High rates of mortality were observed for some isolates. In field experiments with four to six applications of *B. thuringiensis* per year against the olive fruit fly *B. oleae*, fruit infestation was reduced by 60% to 80% (Navrozidis et al., 2000).

Entomopathogenic fungi

Many studies have been conducted on the control of *C. capitata* with different entomopathogenic fungi, such as *Metarhizium anisopliae* (Garcia et al., 1984; Garcia et al., 1985; Garcia et al., 1989; Dimbi et al., 2003b; Ekesi et al., 2003; Dimbi et al., 2004; Ekesi et al., 2005; Mochi et al., 2006) or *Beauveria bassiana* (Castillo et al., 2000; Ekesi et al., 2002; Dimbi et al., 2003a; Queseda-Moraga et al., 2006). Moreover, recent studies revealed good effects of entomopathogenic fungi against other fruit fly species: *A. ludens* (Lezama-Gutierrez et al., 2000; De La Rosa et al., 2002; Toledo et al., 2007), *Anastrepha fraterculus* Schiner (Carneiro & Salles, 1994; Destefano et al., 2005), *B. oleae* (Anagnou-Veroniki et al., 2005; Konstantopoulou & Mazomenos, 2005), and *B. tryoni* (Carswell et al., 1998). Yee and Lacey (2005) demonstrated that adult western cherry fruit flies (*R. indifferens*) are susceptible to *M. anisopliae*. At the present time, however, little is known on fungal pathogens of *R. cerasi*. Wiesmann (1933b) described adult flies as being susceptible to *Empusa* sp. (Zygomycetes: Entomophthoraceae). However, no research has been done on the use of hyphomycetous fungi to control *R. cerasi*.

Entomopathogenic nematodes

Various fruit fly species are known to be susceptible to entomopathogenic nematodes (Lindgren & Vail, 1986a; Lindgren & Vail, 1986b; Gingrich, 1993; Patterson Stark & Lacey, 1999; Gazit et al., 2000; Toledo et al., 2005; Toledo et al., 2006). Yee & Lacey (2002) showed good efficacy of *Steinernema* sp. against larvae of the western cherry fruit fly *R. indifferens*. Moreover, recent laboratory studies have indicated promising results of entomopathogenic nematodes to control the third instar larvae of *R. cerasi* (Köppler et al., 2005b). However, results of laboratory experiments conducted in the scope of the European COST 850 project were disappointing: in a screening of 18 different nematode strains, the highest mortality rates in third instar larvae were below 30% (observed after application of *Steinernema feltiae* at a concentration of 2×10^6 infective juveniles m^{-2} on soil, data not published). This discrepancy might be due to the fact that Köppler et al. (2005b) used larvae obtained from dissected fruit, whereas only larvae ready for pupation that had exited from cherries on their own were used in the COST 850 experiments. In addition, *R. cerasi* larvae pupate at a depth of only 3 to 5 cm and within two hours after leaving the fruit, whereas entomopathogenic nematodes prefer to stay in the moist zones of the soil. Due to the limited time frame and the different spatial activity, the potential for entomopathogenic nematodes for controlling *R. cerasi* under field conditions was considered to be rather small. Indeed, field applications of *S. feltiae* and *S. carpocapse* at the rate of 2×10^6 infective juveniles m^{-2} in a cherry orchard in Aesch (BL, northwestern Switzerland) in June 2003 reduced the emergence rate of adults the following year by only 33% (*S. carpocapse*) and 41% (*S. feltiae*), respectively (Kuske et al., 2005). Similar results (20% reduction of emerging adults) were obtained by Herz et al. (2007), who conducted field experiments with *S. feltiae* to control *R. cerasi* and noted that the effect of nematodes was masked by high natural pupal mortality during the winter.

Parasitoids

Most Tephritid species are attacked by a complex of native parasitoids (Narayanan & Chawla, 1962; Wharton & Gilstrap, 1983; Wharton, 1989; Gingrich, 1993; Sivinski et al., 1998; Lopez et al., 1999; Ovruski et al., 2000; Sivinski et al., 2001). For *R. cerasi*, 21 species of parasitoids (larval ectoparasitoids, larval endoparasitoids and puparium parasitoids) have been described (Hoffmeister, 1993). No egg parasitoids of *R. cerasi* are mentioned in literature.

In cherry production, however, the effectiveness of larval parasitoids is greatly impaired by the short ovipositor of parasitoid females, which cannot reach *R. cerasi* larvae in large cultivated cherries. Monaco (1984) observed that 10 to 30% of *R. cerasi* larvae in wild cherries (*Prunus mahaleb*) are parasitized by *Opius magnus* Fischer (Hymenoptera: Braconidae), whereas no parasitization was observed in cultivated cherries. Similar observations were made by Haisch et al. (1978) and Hoffmeister (1992a), who noted that *R. cerasi* individuals from *Lonicera* sp. generally show higher levels of parasitization than individuals from cultivated cherries: *O. magnus* (Hoffmeister, 1992a) and *Halticoptera laevigata* Thoms. (Hymenoptera: Pteromalidae) (Hadersold, 1939; Hoffmeister, 1992a) have only be observed in individuals from *Lonicera* sp., whereas *Opius rhagleticolus* Sachtl. (Wiesmann, 1936; Hoffmeister, 1992a) was also found in individuals from cherries – although in lower numbers. Contrary to these observations, Leski (1963) showed *O. rhagleticolus* to

be the principal parasitoid of cherry fruit flies in Poland. However, with parasitization rates of 22 to 32%, *O. rhagleticolus* could not control *R. cerasi* populations (Leski, 1963).

Pupal parasitization seems to be more important. *Phygadeuon wiesmanni* Sachtl. (Hymenoptera: Ichneumonidae) occurs throughout Central Europe (Wiesmann, 1933a; Hadersold, 1938; Vogel, 1950; Ahmad & Carl, 1966; Boller, 1966b; Carl, 1968; Hoffmeister, 1992b) and has been shown to be responsible for a pupal mortality rate as high as 72% (Boller, 1966b; Engel, 1976). Under bushes of *Lonicera* sp., however, the parasitization rates of pupae were found to be higher than under cherry trees (Thiem, 1934). Other puparium parasitoids, such as *Phygadeuon elegans* Förster (Carl, 1968), *Gelis bremeri* Haberm. (Hymenoptera: Ichneumonidae) (Thiem, 1934; Leski, 1963; Hoffmeister, 1992a), *Polypeza försteri* Kieff. (Hymenoptera: Diapriidae) (Sachtleben, 1934), and *Spilomicrus hemipterus* Marshall (Hymenoptera: Diapriidae) (Hoffmeister, 1992a), were observed in lower numbers.

Predators

Wiesmann (1933b) mentions two species of *Odontothrips* sp. (Thysanoptera: Thripidae) attacking the eggs of *R. cerasi*. However, the impact of these predators is considered to be low, as only 10% of the eggs were attacked (Wiesmann, 1933b) and as Boller (1966b) did not observe these predators in his comprehensive studies. Therefore, *R. cerasi* is most likely to be attacked by predators only during the short time span after leaving the fruit and pupation or immediately after emergence. Ants (*Myrmica laevinodis*, Hymenoptera: Formicidae), carabid beetles (*Anisodactylus binotatus*, Coleoptera: Carabidae) or staphylinid beetles (*Paedrus litoralis*, Coleoptera: Staphylinidae) are of particular importance (Wiesmann, 1935a; Boller, 1966b). Boller (1966b) noted that up to 80% of larvae were destroyed by predators before pupation, and that ants seemed to be the most important enemy. According to Boller (1966b), however, ants are not able to detect and crack the puparia in the soil. This is in contrast to Sajo (1902a), who observed ants attacking and destroying pupae in the soil. Schwöpe (1957) noted that ants attacked and killed about 40% of the emerging flies. In addition, Boller (1966b) observed in his experiments that about 15% of pupae were destroyed by small, unidentified organisms believed to be mites.

5.11. History of cherry fruit fly control

The strategies used to control *R. cerasi* reflect the history of insect control in general. Peaks of research activity for new control strategies coincide with periods of increasing cherry fruit fly populations: The cherry fruit fly usually exhibits four- to five-year periods of high population densities followed by an interval of decline to very low population levels. Boller et al. (1970) present the data for Switzerland from 1929 to 1969 and note that fluctuations in population density are frequently observed throughout Central Europe at the same time. During the first cherry fruit fly outbreak in the 1930s, research mainly focused on bionomics and behaviour of the pest. Initial control methods focused on destruction of infested fruit and the application of inorganic insecticides. During the second wave of high populations in the mid-forties and early fifties, new insecticides (DDT and organophosphorus compounds) were introduced. During the early sixties, the focus shifted toward the development of biotechnical and biological control methods.

Before insecticides were available, farmers knew that an early and complete harvest was the most effective control measure for *R. cerasi* (Mik, 1898; Verguin, 1928; Sprengel, 1932a;

Sprengel, 1932b; Stellwaag, 1933; Wiesmann, 1934a). Moreover, the growing of early ripening varieties was recommended (Sprengel, 1932a). Soil treatments to kill the pupae were found to be ineffective (Frank, 1891; Sprengel, 1931; Sprengel, 1932a; Wiesmann, 1933b; Thiem, 1934). The recommendation of eradicating wild and secondary hosts (*Lonicera sp.*) of *R. cerasi* was controversially discussed between Thiem (1939) and Wiesmann (1937a). However, because the flies from *Lonicera sp.* emerge a few days later than the flies from cherries (Boller & Bush, 1974) and because the flies from *Lonicera sp.* show a strong preference for *Lonicera sp.* berries for oviposition (Boller et al., 1998), it is doubtful whether this recommendation is necessary or justified.

Thiem (1934) reviewed the early history of insecticide application to control *R. cerasi*. The first insecticides (pyrethrum, rotenone, lead arsenate) were applied in combination with food baits aimed at adult flies (Berlese, 1906; Sprengel, 1932b; Wiesmann, 1934b). However, the efficacy of pyrethrum and rotenone was poor, and lead arsenate was not considered as an option in most European countries due to its high human toxicity (Sprengel, 1932a). Better results were achieved with DDT applications to control adult flies (Wiesmann, 1943; Vogel, 1953; Fenili & Zocchi, 1954; Schwöpe, 1957). However, applications had to be timed exactly to the emergence of flies and repeat treatments were necessary. With the development of organophosphates and carbamates, a systemic control of eggs and larvae inside the fruit became possible (Fenili, 1951; Bartolini & Zocchi, 1957). The emphasis of control shifted from the adult to the egg and larval stages. The application date and therefore the flight period became less important. Applications were timed according to the degradation of the various products, as pesticide residues in the harvested crop had to be avoided (Galli, 2004).

In order to avoid toxic residues on harvested fruit, great efforts were made to find biological or biotechnical control methods. Different approaches were considered: yellow sticky traps, synthetic host-marking pheromones, and sterile male releases (Boller et al., 1970; Boller & Bush, 1974; Boller et al., 1976; Matolin, 1976).

Sticky traps were developed based on the visual preference of the flies for the colour yellow (Boller, 1983). These traps were used for monitoring, forecasting and mass trapping purposes. In order for mass trapping strategies to be effective, however, several traps per tree are needed (Boller, 1972), thus making this strategy uneconomical.

The use of the host-marking pheromone to prevent oviposition was investigated in the 1970s (Katsoyannos, 1975; Katsoyannos & Boller, 1980; Hurter et al., 1989). In field experiments using naturally derived pheromone, an efficacy of 63 to 90% was observed (Katsoyannos & Boller, 1976; Katsoyannos & Boller, 1980). High synthesis costs, however, prevented the use of this pheromone in commercial cherry growing. In addition, efficacy was low at high infestation levels and under rainy conditions. Moreover, about 10% of the trees had to remain untreated in order to provide unmarked fruits for oviposition (Aluja & Boller, 1992).

The sterile insect technique for cherry fruit fly control was developed between 1960 and 1980 (Boller, 1970; Boller et al., 1976; Boller & Remund, 1983; Blümel & Russ, 1989; Ranner, 1990). The major bottle-neck of this technique is the artificial rearing of the fly (Boller et al., 1970; Boller & Ramser, 1971; Katsoyannos et al., 1977). Several points in the insect's biology complicate rearing: *R. cerasi* is univoltine, has an obligatory diapause of at least 150 days, and *R. cerasi* is monophagous with a strongly selective host choice (Katsoyannos,

1975). The lack of a suitable rearing method for producing enough sterile insects for mass releases prevented this strategy from being commercially introduced.

Currently, one application of Dimethoate is still the standard for controlling *R. cerasi* in Swiss sweet cherry production, because it is by far the most cost-efficient method. In Germany, however, this active ingredient is no longer registered for use in fruit production because of problems of ecotoxicity and residues on harvested cherries. In organic production systems, the cherry fruit fly is more difficult to manage, as there are no approved insecticides. Yellow sticky traps are used to reduce the population level. With the increasing number of dwarf tree orchards covered against rain to avoid splitting of the fruit in large sized cherry varieties, crop netting has become a viable, cost-effective method of cherry fruit fly control (Caruso & Cera, 2004).

Part A – Laboratory experiments with entomopathogenic fungi

A.1. Introduction

The use of micro-organisms as biological control agents might be an alternative approach to control *R. cerasi*. Many studies have been conducted on the control of *C. capitata* with different entomopathogenic fungi, such as *Metarhizium anisopliae* (Garcia et al., 1984; Garcia et al., 1985; Garcia et al., 1989; Dimbi et al., 2003b; Ekesi et al., 2003; Dimbi et al., 2004; Ekesi et al., 2005; Mochi et al., 2006) or *Beauveria bassiana* (Castillo et al., 2000; Ekesi et al., 2002; Dimbi et al., 2003a). Moreover, recent studies revealed good effects of entomopathogenic fungi against other fruit fly species: *A. ludens* (Lezama-Gutierrez et al., 2000; De La Rosa et al., 2002), *A. fraterculus* (Carneiro & Salles, 1994; Destefano et al., 2005), *B. oleae* (Anagnou-Veroniki et al., 2005; Konstantopoulou & Mazomenos, 2005), and *B. tryoni* (Carswell et al., 1998). Yee and Lacey (2005) demonstrated that adult western cherry fruit flies (*R. indifferens*) are susceptible to *M. anisopliae*. However, as yet little is known on fungal pathogens of *R. cerasi*. Wiesmann (1933b) described adult flies as being susceptible to *Empusa* sp. (Zygomycetes: Entomophthoraceae). However, no research has been done on the use of hyphomycetous fungi to control *R. cerasi*.

The aim of this series of laboratory experiments was to determine the effects of different fungus isolates on the mortality of different life stages of *R. cerasi* in order to find an effective biocontrol agent for this important pest insect.

A.2. Materials & methods

A.2.1. Source of insects

Following the methods for the laboratory rearing of *R. cerasi* described by Boller (1989b), I was unable to produce enough vigorous flies for the trials. Therefore, field collected insects were used for all experiments. Infested cherries were collected at different locations in northwestern Switzerland in July 2004, 2005, and 2006 and were placed on grids above moist silica sand for two to seven days. Mature larvae dropped into the sand and pupated. The sand was sieved to collect pupae. Pupae were treated with 0.15% brompropylate (product: Spomil, Maag Agro, Dielsdorf, Switzerland; +0.05% Tween®80; Merck-Schuchardt, Hohenbrunn, Germany) and rinsed with alcohol (70%) to avoid mite and fungus infections during diapause. In order to break the diapause, pupae were placed in cold storage at 1 to 4°C for at least 160 days prior to the beginning of the experiment. Because emergence rate is highly dependent on the duration of cold storage (Haisch, 1975), the number of flies available for the experiments was difficult to predict. Therefore, the number of flies per replicate differed between experiments.

All flies were maintained under 16h L : 8h D at a light intensity of 3000 lux and at 23°C (day) / 17°C (night) and a relative humidity of 65%, as described by Boller (1989b). Flies were kept in clear round plastic cages (10 cm diameter x 25 cm height). The tops of the cages were covered with a fine mesh netting to provide ventilation. The flies were provided with water and food immediately after emergence. Food and water were changed weekly. Food strips were prepared according to Boller (1989b) with a 4/1/4 mixture of sugar, yeast hydrolysate

(No.12011, Sonaris AG, Rheinfelden, Switzerland) and water. Small strips of paper towels were soaked in this slurry and dried in an oven at 60°C for four hours.

A.2.2. Source and culture of entomopathogenic fungi

The fungus isolates used in the experiments, *Beauveria bassiana*, *Metarhizium anisopliae*, and the common entomopathogenic species of *Isaria*, *I. farinosa* (= *Paecilomyces farinosus*) and *I. fumosorosea* (= *Paecilomyces fumosoroseus*), are anamorphs of Hypocreales (Sordariomycetes) (Luangsa-Ard et al., 2005). Most isolates were field collected in Switzerland by Dr. Siegfried Keller and maintained at the Agroscope Research Station ART Reckenholz, Zurich (Table 1). Two commercial fungus isolates from the products Naturalis-L (Intrachem Bio Italia S.p.A.) and PreFeRal® WG (Biobest N.V., Belgium) were also included in the experiments.

Table 1: Source of fungus isolates used in laboratory experiments; all field collected isolates were obtained from Agroscope Research Station ART Reckenholz, Zurich.

Code	Fungus	Sample site, date and method
Ifr 531	<i>Isaria fumosorosea</i> (Wize) Brown & Smith; isolate 531	Rietberg GR, Switzerland, 24 March 1998, from soil, Galleria-bait method (Zimmermann, 1986)
Ifr 97	<i>Isaria fumosorosea</i> (Wize) Brown & Smith; strain Apopka 97	Commercial product: PreFeRal®WG (Biobest N.V. Belgium)
Ifa 954	<i>Isaria farinosa</i> (Dicks) Brown et Smith, isolate 954	Matten (Interlaken) BE, Switzerland, 29 September 2003, from soil, Galleria-bait method
Ma 714	<i>Metarhizium anisopliae</i> (Metschnikoff) Sorokin ; isolate 714	Jenaz GR, Switzerland, 28 August 2001, isolated from infested wireworm (Coleoptera: Elateridae)
Ma 786	<i>Metarhizium anisopliae</i> (Metschnikoff) Sorokin ; isolate 786	Grafenort OW, Switzerland, 30 November 2001, isolated from infested <i>Amphimallon solstitialis</i> (Coleoptera: Scarabaeidae)
Bb 74040	<i>Beauveria bassiana</i> (Balsamo) Vuillemin; strain ATCC 74040	Commercial product: Naturalis-L (Intrachem Bio Italia S.p.A.)

All fungi (including the two commercial strains) were cultured in Petri dishes on semi-selective medium adapted from Strasser et al. (1996) with the following composition and preparation: 10 g proteose peptone (LP0085, Oxoid Ltd., Basingstoke, UK), 20 g glucose (D(+)-Glucose monohydrate; 49159 Fluka Chemie AG, Buchs, Switzerland), 18 g agar (Agar bacteriological, Agar No. 1; LP0011, Oxoid Ltd., Basingstoke, UK), dissolved in one litre distilled water and autoclaved at 120°C for 20 minutes. At a temperature of 50°C, 0.6 g streptomycin sulphate (S-9137, Sigma-Aldrich Chemie GmbH, Steinheim, Germany), 0.05 g tetracycline (87128 Fluka Chemie AG, Buchs, Switzerland), 0.05 g cycloheximide (PESTANAL®, 46401, Sigma-Aldrich Chemie GmbH, Steinheim, Germany) and 0.1 ml dodine (Dodine 410S, 410 g l⁻¹, Schneiter Agra AG, Möriken, Switzerland) dissolved in 10 ml distilled water were added by sterile filtration (filter: 0.2 µm, Cromafil CA-20/25S, Machery-Nagel, Düren, Switzerland). Fungus cultures on Petri dishes were incubated at a temperature of 20 to 25°C for 21 to 37 days. Mature cultures were stored at 5 to 7°C until required (see below for specifics).

Conidia suspensions were prepared using distilled water containing 0.05% Tween®80 (Merck-Schuchardt, Hohenbrunn, Germany) and by scraping mature cultures with a Trigalsky spatula and removing the suspension with a pipette. The final conidia concentration was adjusted after conidial counts using a haemocytometer (Thoma chamber). The viability of the

conidia of each isolate was tested immediately after experiments were started by spread-plating the conidia suspension onto water agar plates (Agar No. 1; LP0011, Oxoid Ltd., Basingstoke, UK; 15 g l⁻¹). Plates were incubated at 20°C. Percent germination after 24 and 48 hours was determined by counting the number of germinated conidia per 100 conidia in at least three separate areas per plate under the microscope (312.5x magnification). Conidia were considered to have germinated if the germ tube was longer than the diameter of the conidium.

A.2.3. Experiments with adult *R. cerasi*

Flies were evenly distributed among the different treatments and replicates according to their sex and age. For the conidia treatments, flies were kept in small plastic tubes (3 cm diameter x 12 cm length) with fine mesh netting (0.4 mm mesh size) on both sides. Flies were sprayed until run-off (2 ml per replicate) with a fine mist of conidia suspension using a hand-held, air-assisted spraying equipment (Devilbiss SRI 510, 1 bar). Control flies were treated with distilled water containing 0.05% Tween®80. After treatment, the tubes were placed upright to allow the excess suspension to run off. Two hours after treatment, the flies were placed in cages and the cages were randomly arranged within the climate chamber.

The method of Dimbi et al. (2003a) was used to estimate the number of conidia per fly after treatment. Flies (11 males, 10 females) were treated with 2 ml conidia suspension (1x10⁷ conidia ml⁻¹) of *M. anisopliae* 714 as described above. Immediately after treatment, flies were individually transferred to 1.5 ml microcentrifuge tubes (Eppendorf) containing 1 ml sterile distilled water with 0.05% Tween®80. The tubes were sonicated at 35 kHz for three minutes and vortexed for five minutes to detach conidia from the flies. The tubes were centrifuged for two minutes at 14000 rpm using an Eppendorf microcentrifuge. Subsequently, 800 µl of the resulting supernatant were discarded and the conidia pellet was re-suspended in the remaining 200 µl. The concentration of the conidia suspension was then determined using a haemocytometer (Thoma chamber), and the number of conidia per fly was calculated.

Fly mortality was assessed at 24 h intervals over a period of 32 days. Dead flies were placed individually on moist peat and incubated at 20°C to confirm mycosis. First signs of fungus outgrowth were often visible after 24 hours. However, the final assessment was made after four days. Only flies showing clear sporulation were considered to have died from fungus infection.

Effects on fecundity were assessed by counting the number of eggs laid during the total time of the experiment. Grapes were used as suggested by Geipel (2001), as the flies did not oviposit in wax spheres as described by Boller (1989b). The grapes were thoroughly washed, rinsed with alcohol (70%) and water, and two berries were hung in the middle of each cage (replicate). The berries were changed daily and number of eggs was counted using a binocular microscope (6.3x magnification). The five experiments conducted with adult flies are described below:

Efficacy of different fungus isolates against adult *R. cerasi*

In the first experiment, flies were treated with the fungus isolates *I. fumosorosea* 531, *I. farinosa* 954, *M. anisopliae* 714, *M. anisopliae* 786 and *B. bassiana* ATCC 74040 at a concentration of 1x10⁷ conidia ml⁻¹. Five replicates with five female flies and seven male flies

each were set up. Flies were obtained from field collections in Arlesheim BL, Switzerland in 2004. At the beginning of the experiment, flies were one to five days old. Fungi used for treatments were cultured for 28 days at 25°C.

A second experiment was conducted with the same fungus isolates and concentration as in the first experiment, but with flies obtained from another orchard (Eptingen BL, Switzerland; 2004). Five replicates with five female flies and two male flies each were set up. At the beginning of the experiment, the flies were zero to eight days old. The fungi used for the treatments were cultured for 21 days at 25°C.

Effect of conidia concentrations on mortality of adult *R. cerasi*

In a third experiment, the effect of conidia concentration on fly mortality was assessed. Flies were treated with the fungus isolates *I. fumosorosea* 531, *I. fumosorosea* Apopka 97, *M. anisopliae* 714 and *B. bassiana* ATCC 74040 at concentrations of 1×10^7 conidia ml⁻¹, 5×10^5 conidia ml⁻¹ and 2.5×10^4 conidia ml⁻¹. Five replicates per isolate and concentration with nine female flies and five male flies each were set up. Flies were obtained from field collections in Hottwil AG, Switzerland in 2005. At the beginning of the experiment, the flies were one to five days old. The fungi used for the treatments were cultured for 33 days at 20°C.

Effect of age of adult *R. cerasi* on the efficacy of fungus treatments

In the fourth experiment, the effect of the age of the flies at the time of treatment on mortality was examined. The fungus isolates *I. fumosorosea* 531, *I. fumosorosea* Apopka 97, *M. anisopliae* 714 and *B. bassiana* ATCC 74040 were applied at a concentration of 1×10^7 conidia ml⁻¹ on three age groups of flies: zero to one day old flies, three to four day old flies, and six to seven day old flies. Five replicates per isolate and age group with eight female flies and eight male flies each were set up. Flies were obtained from field collections in two orchards (Hottwil AG and Sissach BL, Switzerland; 2005). The fungi used for the treatments were cultured for 37 days at 20°C and placed in cold storage for 10 days at 5 to 7°C. In this experiment, the fertility of eggs was assessed by dissecting the first 50 eggs laid per treatment from the grapes. Eggs were placed on wet black filter paper and incubated in a climate chamber. The number of hatched larvae was counted at 24 h intervals.

Experiment on fly-to-fly conidia transfer between adult *R. cerasi*

The fifth experiment was conducted to assess the effect of fly-to-fly conidia transfer. For this experiment, one and two day old flies were treated with conidia suspension. Treated females were introduced in cages with untreated males and vice versa. The fungus isolates *I. fumosorosea* 531, *I. fumosorosea* Apopka 97 and *B. bassiana* ATCC 74040 were applied at a concentration of 1×10^7 conidia ml⁻¹. Four replicates with five female flies and five male flies each were set up. Fly mortality was assessed at 24 h intervals for 20 days. The flies were obtained from field collections in two orchards (Hottwil AG and Aesch BL, Switzerland; 2004). The fungi used for the treatments were cultured for 46 days at 24°C and kept in cold storage for 33 days at 5 to 7°C. Fecundity was not recorded in this experiment.

A.2.4. Soil treatments to control emerging flies

This experiment was conducted to evaluate the efficacy of soil treatments with fungus isolates on *R. cerasi* during emergence. Pupae were obtained from field collections in Hottwil

AG, Switzerland in 2005 and were evenly distributed by weight among treatments and replicates. Per replicate, 25 pupae were kept in a small black plastic box (4.3 cm diameter x 4.3 cm height) and incubated under the conditions described above. The soil used for this experiment was obtained from a cherry orchard in Aesch (BL) in northwestern Switzerland (35% clay, 46% silt, 17% sand, 2% organic matter). The soil was sieved (2 mm), dried and kept in cold storage until the experiment. The field capacity of the soil was determined (0.799 ± 0.006 g H₂O per g dry matter). One day before the flies started to emerge, the pupae were covered with a 2 cm layer of soil (20 g of dry soil per box). Spores were applied by evenly spreading 2 ml of conidia suspension (1×10^8 conidia ml⁻¹) over the soil surface in each box (1×10^7 conidia g⁻¹ of dry soil). The fungus isolates used for treatments, *I. fumosorosea* 531, *I. fumosorosea* Apopka 97, *M. anisopliae* 714 and *B. bassiana* ATCC 74040, were cultured for 31 days at 20 to 23°C. Two different moisture levels, 35% field capacity and 45% field capacity, were obtained by adding additional water to the soil. The boxes were weighed regularly and water was added if necessary to keep the moisture levels in a range of 30 to 37.5% and 40 to 47.5% field capacity, respectively, over the whole experimental period. Six replicates per isolate and moisture level with 25 pupae each were set up. Untreated soil at the same moisture levels and pupae without soil were used as controls. The boxes were closed with a black lid and placed in the cages described above. After emergence, the flies were able to escape from the soil-filled boxes through a 5 mm hole in the lid. Emergence rate and mortality were assessed at 24 h intervals over a period of 36 days. Dead flies were placed individually on moist peat and incubated at 20°C to confirm mycosis. Effects on fecundity were assessed by counting the number of eggs laid in grapes from day 8 until the end of experiment. Grapes were exposed to the flies as described above and changed at two day intervals. The number of eggs was counted using a binocular microscope (6.3x magnification).

A.2.5. Efficacy of different fungus isolates on larvae of *R. cerasi*

This experiment was conducted to evaluate the efficacy of the fungus isolates on mature larvae of *R. cerasi* shortly before pupation. The larvae were collected at Aesch (BL, Switzerland) on 13 July 2005 by covering the soil under infested cherry trees with large cotton sheets. Mature larvae dropping from fruit were collected from these sheets within five minutes after dropping and dipped for five seconds in a 1×10^7 conidia ml⁻¹ suspension. The fungi used for the treatments were cultured for 36 days at 20 to 25°C and kept in cold storage for 27 days at 5 to 7°C. The fungus isolates *I. fumosorosea* 531, *I. fumosorosea* Apopka 97, *I. farinosa* 954, *M. anisopliae* 714, *M. anisopliae* 786 and *B. bassiana* ATCC 74040 were tested. Control larvae were dipped in sterile distilled water containing 0.05% Tween®80. Because the larvae were treated in the orchard on a very sunny day, close attention was paid to the viability of the conidia suspensions: suspensions were sheltered from UV radiation by dense black sheets, the temperature of the suspensions was continuously monitored and ranged from 23°C to 28°C. The viability of the conidia of each isolate was tested immediately before the beginning of the experiment and after treatments as described above. Four replicates with six mature larvae each were set up. Immediately after treatment, the larvae were placed in small plastic boxes (46 mm diameter; 42 mm height) on moist silica sand (40 g sand; 5 ml water) to allow pupation. The pupation rate was evaluated after eight days. All pupae and dead larvae were placed on moist peat and incubated at 22°C to allow fungal growth. Pupae were checked daily for 25 days. After this

period, pupae with no signs of mycosis were stored at 1 to 4°C for 160 d to break diapause. The pupae were then transferred to the climatic chamber with the settings described above. Emergence and mortality of flies were assessed at 24 h intervals for 75 days. Dead flies were placed on moist peat and incubated at 20°C to confirm mycosis. Pupae that failed to emerge during this period were dissected and placed again on moist peat. Fecundity was not recorded in this experiment.

A.2.6. Statistical analysis

Statistical analyses were conducted using JMP version 5.0.1.2.. The normality of the data and homogeneity of variance were tested. If necessary, data were transformed before performing an ANOVA. Means were compared by Tukey HSD post hoc tests. If normality and homogeneity of variances could not be achieved by transformation, data were analysed by the nonparametric Kruskal-Wallis-Chi-Square test. The number of conidia per fly were $[\log_{10}(x+1)]$ transformed to obtain homogeneity of variances and analysed by one-way ANOVA. The median survival time was estimated for each replicate. These data were $[1/x]$ transformed if necessary and analysed by one-way ANOVA [fungus isolate] or two-way ANOVA [fungus isolate; age of flies]. The cumulative proportion of dead flies five and 30 days after treatment was $[\arcsine(\sqrt{x})]$ transformed and analysed by one-way ANOVA [fungus isolate] or two-way ANOVA [fungus isolate; age of flies]. Means were compared by Tukey HSD post hoc tests ($\alpha=0.05$). The cumulative number of eggs per cage was $[\sqrt{(x+1)}]$ transformed if necessary and analysed by one-way ANOVA [fungus isolate] or two-way ANOVA [fungus isolate; age of flies]. Means were compared by Tukey HSD post hoc tests ($\alpha=0.05$). The efficacy was calculated using Abbott's formula (Abbott, 1925). The egg hatch rate (egg fertility) in the fourth experiment was analysed by a logistic regression model.

The emergence rate and mortality of the flies in the soil treatment experiment were $[\arcsine\sqrt{(x)}]$ transformed before performing a two-way ANOVA [fungus isolate, soil moisture]. The number of eggs per female was analysed by two-way ANOVA [fungus isolate, soil moisture]. Means were compared by Tukey HSD post hoc tests ($\alpha=0.05$). The efficacy was calculated using Abbott's formula (Abbott, 1925).

Data from the experiment with larvae were analysed by the Kruskal-Wallis-Chi Square test. Unless mentioned otherwise, the data presented in the figures, tables and text are means with standard errors.

A.3. Results

A.3.1. Experiments with adult *R. cerasi*

The number of conidia (*M. anisopliae* 714) washed from flies directly after treatment ranged from 2.2 to 8.8×10^4 conidia per fly. On average, females carried slightly more conidia (mean \pm se: $5.1 \pm 0.7 \times 10^4$) than males ($3.9 \pm 0.3 \times 10^4$). However, differences between sexes were not significant (Data transformed $[\log_{10}(x+1)]$; one-way ANOVA: $F_{1,19}=1.84$, $p=0.19$).

Efficacy of different fungus isolates against adult *R. cerasi*

The conidial germination rate in the first experiment exceeded 75% for all fungi after 48 h of incubation, except for Ma 714 (67%). All fungus isolates were pathogenic to *R. cerasi* and caused mycosis. However, virulence was significantly different among fungus isolates. The

median survival time for control flies and flies treated with Ifa 954 could not be estimated, as less than 50% of the flies died during the experiment. For the other fungus isolates, the median survival times ranged from five to seven days after treatment (Figure 6; Bb 74040: 5.0 ± 0.3 days; Ifr 531: 5.4 ± 0.5 days; Ma 786: 5.8 ± 0.4 days; Ma 714: 6.8 ± 0.6 days; differences not significant: one-way ANOVA: $F_{3,16}=2.79$, $p=0.07$). Five days after treatment, the mortality of adult *R. cerasi* in all fungus treatments (except Ifa 954) ranged from 28 to 70%, which was significantly higher than the mortality in the control (5%; Figure 7). Mortality in Bb 74040 (70%) was significantly higher than mortality in Ma 714 (28%). Thirty days after treatment, mortality had increased and reached rates of over 95% for Bb 74040 and Ifr 531 (Figure 7). No significant differences were found among the fungus isolates Ifr 531, Ma 714, Ma 786 and Bb 74040. Mortality in Ifa 954 did not significantly exceed mortality in the control. All flies that died during the first five days after treatment showed mycosis (Figure 8). The rate of mycosis declined during the experiment, especially in Ifa 954 (44% of dead flies showing mycosis on day 30) and Ma 714 (41% mycosis; Ma 786: 94%; Bb 74040: 100%; Ifr 531: 100%). No mycosis was detected in the control flies. Compared to the control, Ifr 531, Ma 714, Ma 786 and Bb 74040 significantly reduced the number of eggs (Figure 7). This resulted in an efficacy of over 90% for the fungi Ifr 531 and Bb 74040 (Ifa 954: 17% efficacy; Ma 714: 77%; Ma 786: 68%; Abbott's formula (Abbott, 1925)).

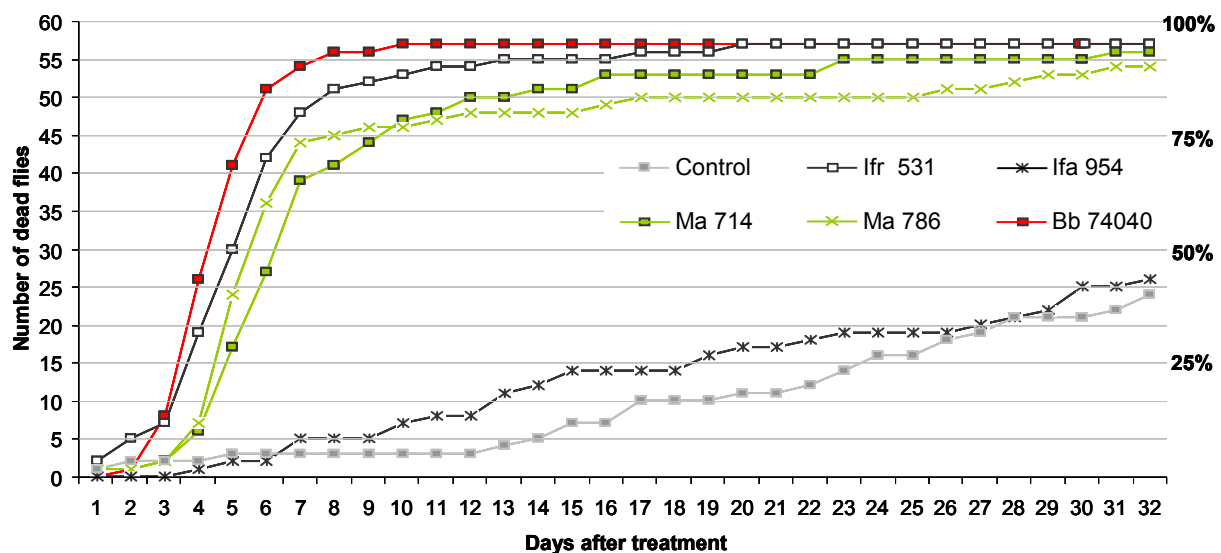

Figure 6: Cumulative mortality of adult *R. cerasi* after treatment with different fungus isolates.

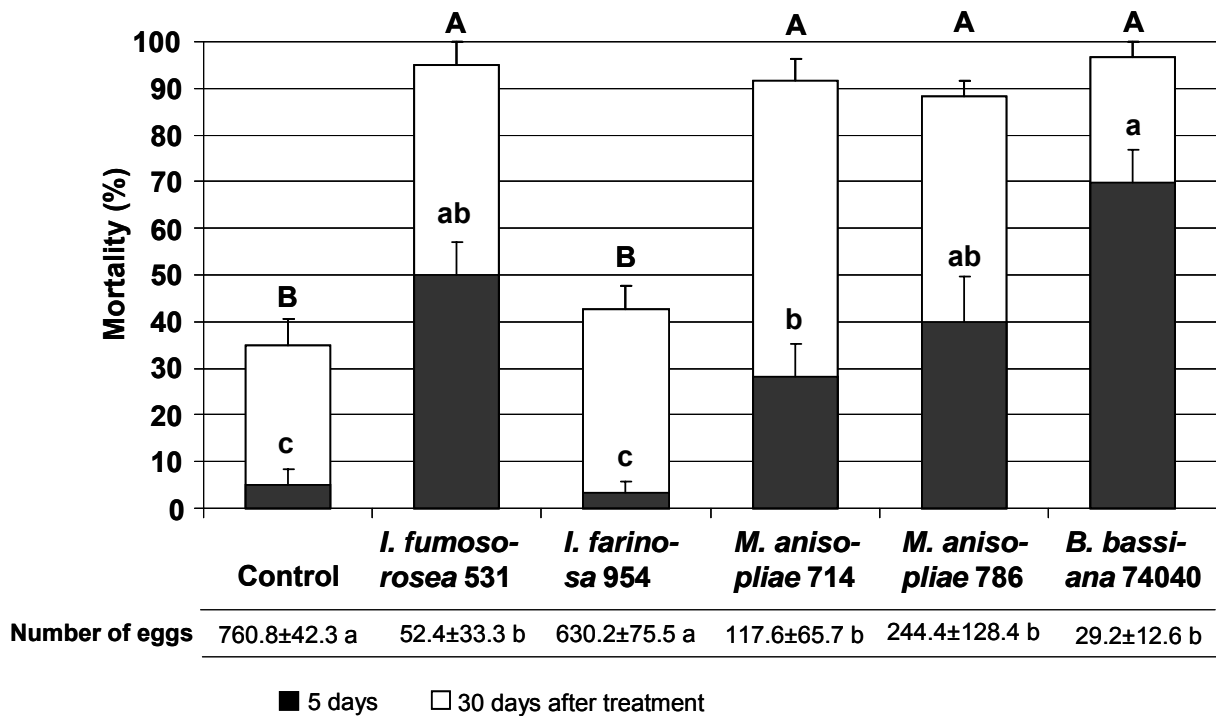

Figure 7: Effects of different fungus treatments on mortality (\pm se) of adult *R. cerasi* (collection site: Arlesheim BL, Switzerland) and on fecundity (number of eggs \pm se). Statistical analysis of mortality: Data transformed [$\arcsin\sqrt{x}$]; one-way ANOVA: Day 5: $F_{5,24}=17.29$, $p<0.001$; Day 30: $F_{5,24}=21.38$, $p<0.001$; Tukey HSD-Test $\alpha=0.05$; Statistical analysis of number of eggs: One-way ANOVA: $F_{5,24}=13.97$, $p<0.001$; Tukey HSD-Test $\alpha=0.05$, different letters show significant differences.

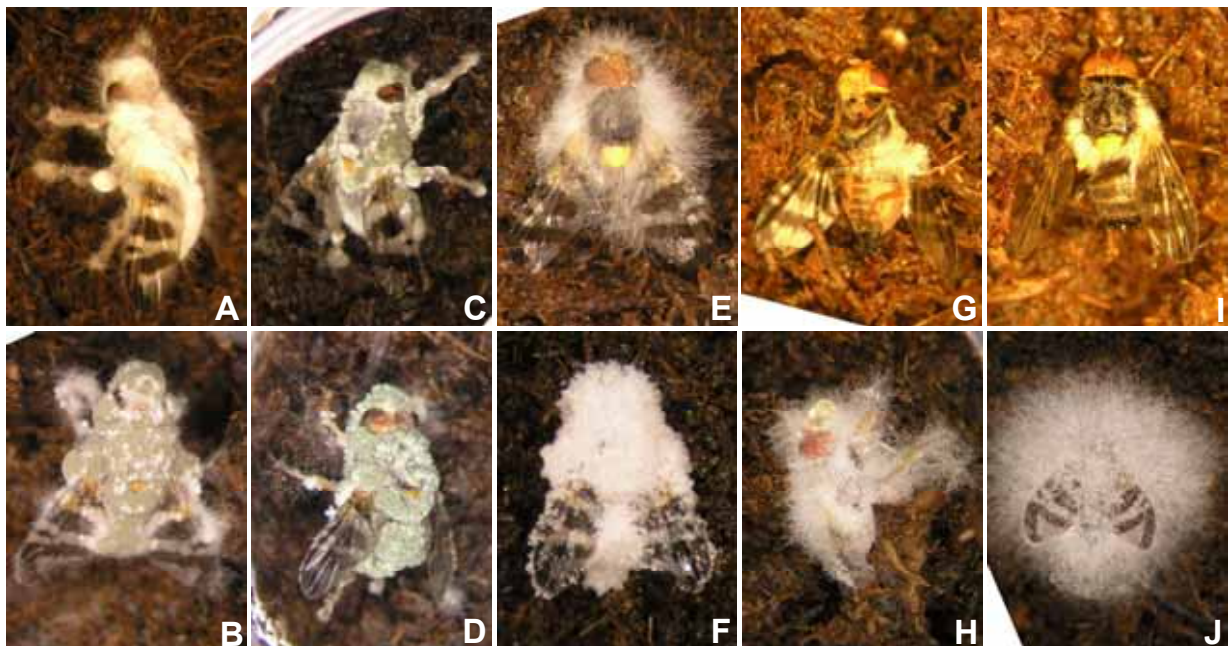

Figure 8: Mycosis of flies placed on moist peat A: Female *R. cerasi* treated with Ma 714, three days after death; B: Male *R. cerasi* treated with Ma 714, five days after death; C: Female *R. cerasi* treated with Ma 786, three days after death; D: Male *R. cerasi* treated with Ma 786, six days after death; E: Female *R. cerasi* treated with Ifr 531, two days after death; F: Female *R. cerasi* treated with Ifr 531, six days after death; G: Female *R. cerasi* treated with Ifr 97, one day after death; H: Female *R. cerasi* treated with Ifr 97, two days after death; I: Male *R. cerasi* treated with Bb 74040, one day after death; J: Female *R. cerasi* treated with Bb 74040, five days after death.

The conidial germination rate in the second experiment exceeded 75% after 48 h of incubation for all fungi, except for Bb 74040 (55%). Again, all fungus isolates were pathogenic to adult *R. cerasi*. The median survival time for the control flies and for the fungus isolates lfa 954 and Ma 786 could not be estimated, as mortality was less than 50% in some replicates. For the other fungus isolates, median survival time ranged between six and nine days (Ma 714: 6.4 ± 0.8 days; Bb 74040: 7.4 ± 0.9 days; lfr 531: 8.8 ± 3.1 days; differences not significant: Data transformed $[1/x]$; one-way ANOVA: $F_{2,12}=0.29$, $p=0.75$). Five days after treatment, only the fungus isolate lfr 531 showed a significantly greater mortality than the control (Figure 9). All fungus isolates significantly increased mortality at 30 days after treatment compared to the control. The mortality of the lfa 954 treated flies was significantly lower than mortality in the other fungus isolates. The dead flies in Ma 714 and lfa 954 only showed a very low rate of mycosis: 50.0% and 27.3%, respectively, whereas 100% of the dead flies in lfr 531, Ma 786 and Bb 74040 showed mycosis. No significant differences in the number of eggs were found. However, Bb 74040 and lfr 531 reduced egg-laying by 79.4% and 70.7%, respectively (Abbott's formula). Although the highest mortality of adult flies was found in Ma 714, efficacy based on the number of eggs was only 36.8% (Ma 786: 50.4% efficacy; lfa 954: 22.7%).

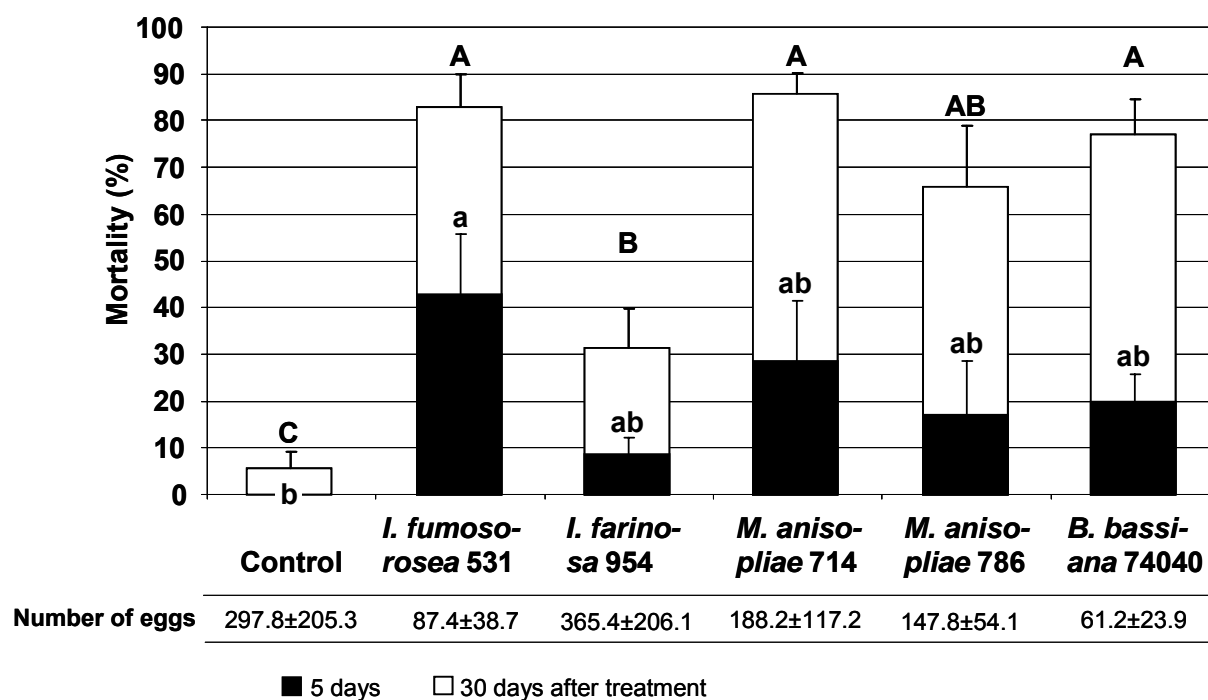

Figure 9: Effects of different fungus treatments on mortality (\pm se) of adult *R. cerasi* (collection site: Eptingen BL, Switzerland) and on fecundity (number of eggs \pm se). Statistical analysis for mortality: Data transformed $[\arcsin\sqrt{x}]$; one-way ANOVA: Day 5: $F_{5,24}=3.11$, $p=0.03$; Day 30: $F_{5,24}=12.76$, $p<0.001$; Tukey HSD-Test $\alpha=0.05$; Statistical analysis for number of eggs: Data transformed $[\sqrt{x+1}]$; one-way ANOVA: $F_{5,24}=0.70$, $p=0.63$; different letters show significant differences.

Effect of conidia concentrations on mortality of adult *R. cerasi*

The conidial germination rate in the third experiment exceeded 75% after 48 h of incubation for all fungus isolates, except for lfr 97 (19%). The median survival time for control flies and for the lowest concentration (2.5×10^4 conidia ml^{-1}) of all fungus isolates could not be estimated. At the highest concentration (1×10^7 conidia ml^{-1}), lfr 531 had the shortest median

survival time (4.4 ± 0.2 days). For the other fungus isolates, the medium survival time ranged between five and six days (Ifr 97: 5.0 ± 0.3 days; Bb 74040: 5.6 ± 0.4 days; Ma 714: 6.2 ± 0.4 days). The median survival time could not be estimated for Ma 714 and Ifr 531 at the concentration of 5×10^5 conidia ml^{-1} ; for Bb 74040 and Ifr 97 the medium survival times were 6.6 ± 0.4 days and 8.6 ± 2.4 days, respectively.

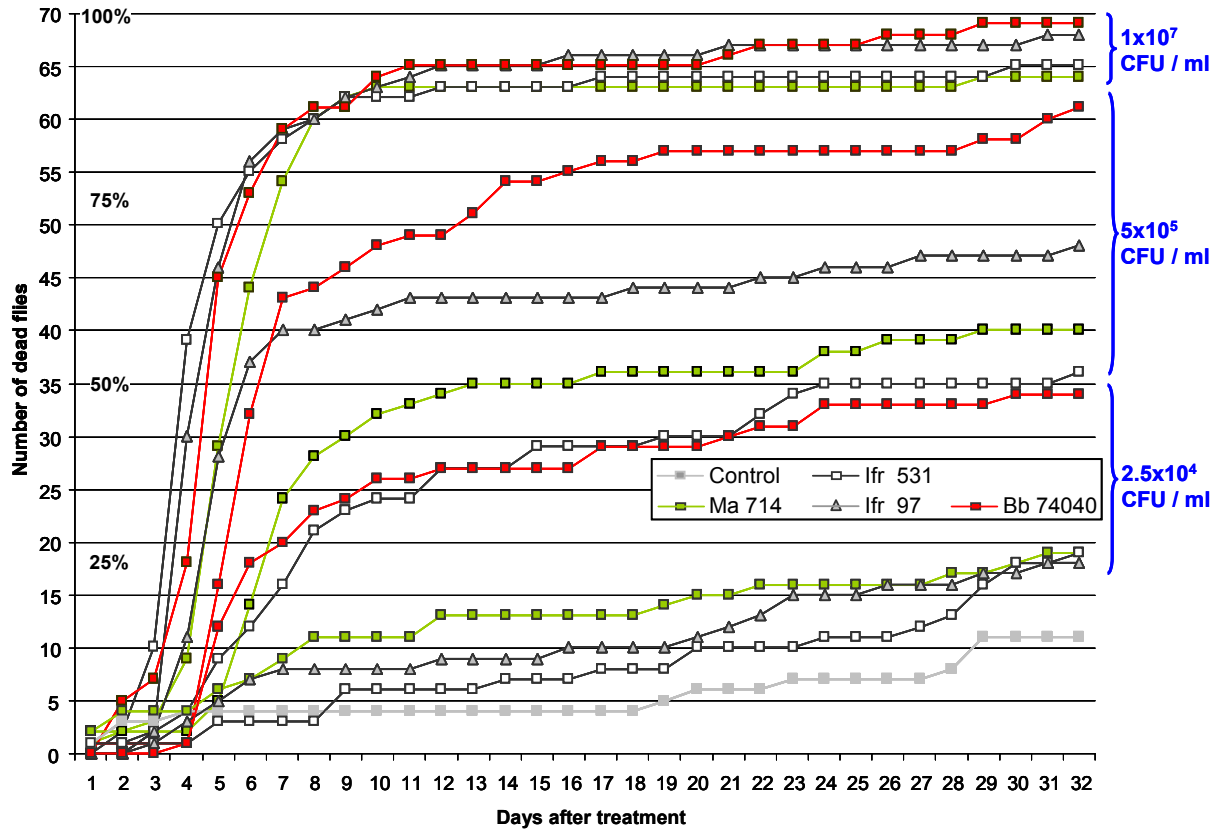

Figure 10: Cumulative mortality of adult *R. cerasi* after treatment with different fungus isolates at three concentration levels.

As expected, mortality increased with increasing concentrations (Figure 10). The highest concentration (1×10^7 conidia ml^{-1}) of each fungus isolate significantly increased mortality compared to the control as well as compared to the lowest concentration of the same isolate within five and 30 days after treatment (Figure 11). The medium concentration of all isolates showed significant differences compared to the control at 30 days post treatment. However, only the mortality for Ifr 97 (5×10^5) was significantly higher than for the control five days after exposure. At the lowest concentration, only Bb 74040 showed a significantly higher mortality than the control at 30 days post exposure. No significant differences were found between the different fungus isolates at the highest concentration, whereas at a concentration of 5×10^5 conidia ml^{-1} , Bb 74040 was significantly more virulent than Ifr 531. At the medium concentration, Bb 74040 showed a mortality rate of 83%, whereas the other fungus isolates killed 50 to 67% of the flies. The mortality rate for the lowest concentration of Bb 74040 was twice as high (49%) as for the other fungus isolates (24 to 26%). In spite of the very low conidia viability, Ifr 97 induced higher mortality rates than Ma 714 and Ifr 351. All flies that died during the first five days after fungus treatment with high concentrations (1×10^7 and 5×10^5) showed mycosis. The percentage of mycosed flies was lower for the treatments with the lowest concentration (Ma 714: 33%; Ifr 531: 67%; Ifr 97: 80%; Bb 74040: 100%). The rate

of mycosis declined during the experiment for all fungus isolates and concentrations. No mycosis was found in the control flies.

At the highest concentration, all fungus isolates significantly reduced the number of eggs (Figure 11). This resulted in an efficacy (Abbott's formula) of over 90% for all fungus isolates (Ma 714: 99.6%; Ifr 531: 99.2%; Ifr 97: 97.2%; Bb 74040: 94.1%). At the medium concentration, only Bb 74040 significantly reduced the number of eggs compared to the control and showed an efficacy of 72.5% (efficacy: Ma 714: 54.6%; Ifr 531: 37.5%; If 97: 54.0%). No significant reduction of eggs was found for the lowest fungus concentrations (efficacy: Bb 74040: 52.7%; Ma 714: 42.6%; Ifr 531: 20.4%; Ifr 97: 10.9%).

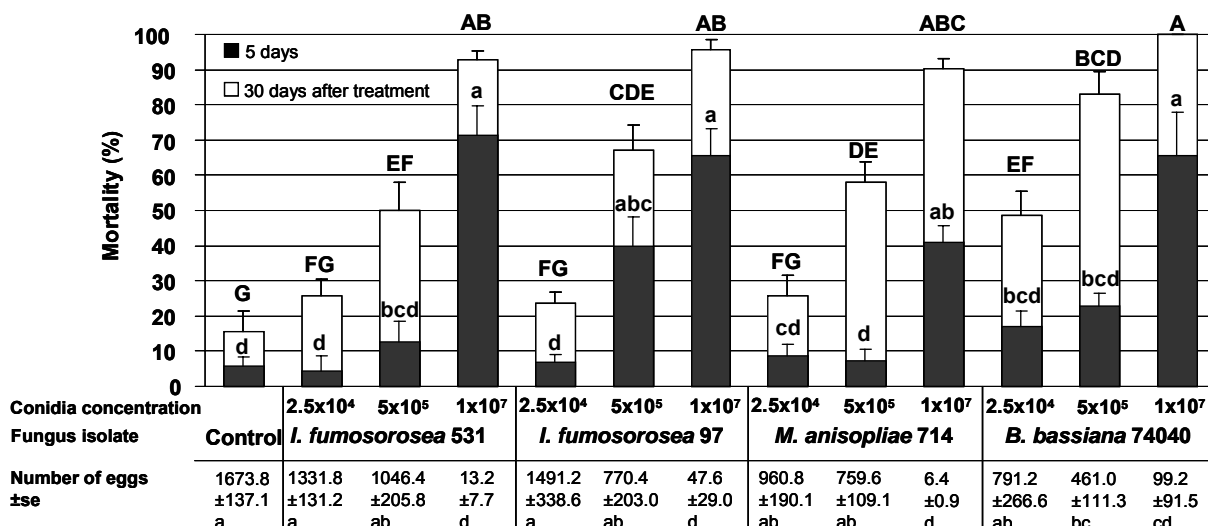

Figure 11: Effects of different fungus treatments on mortality (\pm se) of adult *R. cerasi* (collection site: Hottwil AG, Switzerland) and on fecundity (number of eggs \pm se). Statistical analysis for mortality: Data transformed [$\arcsin\sqrt{x}$]; one-way ANOVA: Day 5: $F_{12,52}=14.49$, $p<0.001$; Day 30: $F_{12,52}=32.97$, $p<0.001$; Tukey HSD-Test $\alpha=0.05$; Statistical analysis for number of eggs: Data transformed [$\sqrt{x+1}$]; one-way ANOVA: $F_{12,52}=21.06$, $p<0.001$; Tukey HSD-Test $\alpha=0.05$, different letters show significant differences.

Effect of age of *R. cerasi* on the efficacy of fungus treatments

The conidial germination rate in the fourth experiment exceeded 75% for all fungus isolates after 48 h of incubation, except for Bb 74040 (27%). The median survival time for control flies and young flies treated with Bb 74040 could not be estimated. For the other fungus isolates, younger flies showed a trend toward a longer median survival time than older flies (two-way ANOVA; Data transformed [$1/x$]; isolate: $F_{2,35}=11.63$, $p<0.001$; age: $F_{2,35}=14.93$, $p<0.001$; isolate*age: $F_{4,35}=1.85$, $p=0.14$). Ifr 531 showed the shortest median survival time with 4.8 ± 0.2 days, 5.2 ± 0.2 days and 6.6 ± 0.7 days for the age groups of 6-7 day old flies, 3-4 day old flies, and 0-1 day old flies, respectively. Flies treated with the fungus isolate Ifr 97 showed median survival times of 5.3 ± 0.4 days, 6.3 ± 0.9 days and 10.0 ± 1.8 days. The median survival times for Ma 714 treated flies were 6.2 ± 0.2 days, 8.6 ± 1.4 days and 7.8 ± 0.4 days for old, middle and young flies, respectively. The same trend was observed for Bb 74040, however, flies survived longer than in the other treatments with higher conidial viability: 9.4 ± 1.4 days (6-7 day old flies) and 13.0 ± 0.8 days (3-4 day old flies).

Five days after treatment, both isolates of *I. fumosorosea* significantly increased mortality in all age groups compared to control (Figure 12). Thirty days after treatment, all age groups in

all fungus isolates (except young flies for Bb 74040) showed a significantly higher mortality than the control. Again, there was a trend toward older flies showing a higher mortality than young flies. Significant differences were found between the oldest and the youngest age groups in the treatments Ifr 97 and Bb 74040.

Fungus treatment significantly reduced the number of eggs, and older flies laid significantly fewer eggs than younger flies (Figure 12). The greatest efficacy (Abbott's formula) was observed in the oldest age group in all fungus isolates: 96.8% (Ifr 531), 95.2% (Ifr 97), 96.7% (Ma 714) and 74.5% (Bb 74040), respectively. For 3-4 day old flies, the efficacy was 97.1% (Ifr 531), 76.7% (Ifr 97), 85.5% (Ma 714) and 54.3% (Bb 74040). For the youngest age group, the efficacy was 76.8% (Ifr 531), 56.6% (Ifr 97), 86.7% (Ma 714) and 23.5% (Bb 74040).

In this experiment, egg fertility (hatch rate) was estimated: In comparison to the control (hatch rate: 79%), the fungus isolates Bb 74040 (hatch rate: 55%) and Ifr 531 (hatch rate: 59%) significantly reduced egg fertility, whereas Ifr 97 (hatch rate: 65%) and Ma 714 (hatch rate: 70%) had no significant effect (logistic analysis of variance; likelihood ratio test: model: $\chi^2=36.65$, $df=6$, $p<0.001$; fungus isolate [factor]: $\chi^2=26.17$, $df=4$, $p<0.001$; age-group [ordinal]: $\chi^2=10.54$, $df=2$, $p=0.005$). There was a significant reduction in egg fertility depending on age of the flies. Fertility was lowest among the youngest flies (hatch rate: 58%). No differences were found between the intermediate age-group (hatch rate: 72%) and the oldest age group (hatch rate: 68%). The interactions between fungus isolate and age group were not significant and therefore not included in the final statistical model.

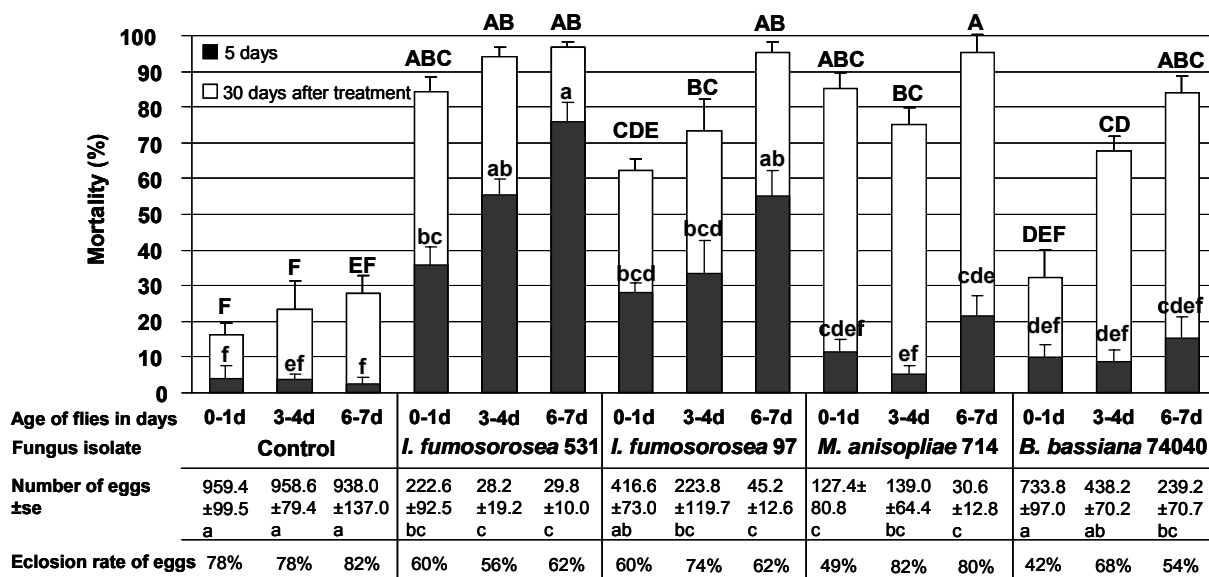

Figure 12: Effects of different fungus treatments on mortality (\pm se) of three age-groups of adult *R. cerasi* (collection sites: Hottwil AG and Sissach BL, Switzerland). Statistical analysis for mortality: Data transformed [$\arcsin\sqrt{x}$]; two-way ANOVA: Day 5: fungus isolate: $F_{4,60}=56.46$, $p<0.001$; age-groups: $F_{2,60}=12.27$, $p<0.001$; isolate*age: $F_{8,60}=2.42$, $p=0.02$; Day 30: fungus isolate: $F_{4,60}=56.49$, $p<0.001$; age-groups: $F_{2,60}=26.37$, $p<0.001$; isolate*age: $F_{8,60}=2.488$, $p=0.009$; Tukey HSD-Test $\alpha=0.05$; different letters show significant differences. Statistical analysis for number of eggs: Data transformed [$\sqrt{x+1}$]; two-way ANOVA: fungus isolate: $F_{4,60}=53.67$, $p<0.001$; age-groups: $F_{2,60}=13.42$, $p<0.001$; isolate*age: $F_{8,60}=2.15$, $p=0.04$; Tukey HSD-Test $\alpha=0.05$, different letters show significant differences.

Experiment on fly-to-fly conidia transfer among adult *R. cerasi*

The conidial germination rate in the fifth experiment was low for Bb 74040 (8%) and exceeded 90% for Ifr 531 and Ifr 97. Treated flies showed high rates of mortality (Ifr 531: 95±3%; Ifr 97: 85±6%; Bb 74040: 55±11%) and 100% mycosis. The mortality of the untreated flies (Ifr 531: 17±9%; Ifr 97: 6±6%; Bb 74040: 23±9%) did not exceed the mortality of the control flies (20±10%). Only two fungus infested flies were found in the untreated group: one male in treatment Bb 74040 within five days after treatment, another male in treatment Ifr 531 at day 20 after treatment.

A.3.2. Soil treatments to control emerging flies

The conidial germination rate exceeded 65% for all fungus isolates after 48 h of incubation, except for Ma 714 (31%).

Comparing the three control treatments (control without soil, soil with moisture content of 35% and 45% field capacity), no effect of soil and soil moisture on emergence rate, mortality and fecundity of *R. cerasi* was found (Emergence rate: Data transformed [$\arcsin\sqrt{x}$]; one-way ANOVA: $F_{2,15}=0.90$, $p=0.43$; Mortality: Data transformed [$\arcsin\sqrt{x}$]; one-way ANOVA: $F_{2,15}=1.94$, $p=0.18$; Number of eggs per female: one-way ANOVA: $F_{2,15}=0.03$, $p=0.97$). Therefore, the control without soil was excluded from further analysis.

Emergence rates of flies were high for all fungus treatments (control: 87.7±2.0%; Ifr 97: 85.3±2.4%; Ifr 531: 89.7±1.6%; Ma 714: 86.7± 1.7%; Bb 74040: 90.3±2.0%). Differences were not significant. However, soil moisture had a significant effect on emergence rate: a higher emergence was observed in the soil with a lower moisture level (90.1±1.1%) than in the soil with a higher moisture level (85.7±1.2%) (Data transformed [$\arcsin\sqrt{x}$]; two-way ANOVA: Fungus isolate: $F_{4,54}=1.30$, $p=0.28$; moisture: $F_{1,54}=6.31$, $p=0.015$). There were no significant interactions between fungus isolate and soil moisture. Interactions were therefore not included in the final statistical model. The emergence period lasted 27 days, with highest emergence rates between day six and day 11 after starting the experiment. Mortality and oviposition rate were evaluated until day nine after the last emergence.

Fly mortality was significantly increased by fungus treatments (Figure 13). Soil moisture had no effect on mortality (Data transformed [$\arcsin\sqrt{x}$]; two-way ANOVA; Fungus isolate: $F_{4,54}=64.49$, $p<0.001$; moisture: $F_{1,54}=0.86$, $p=0.36$). More than 99.5% of the dead flies in the fungus treatments showed mycosis when placed on moist peat. No mycosis was found on dead flies in the control treatment. The number of eggs per female was significantly reduced by fungus treatments applied to the soil (Figure 13) as well as by soil moisture (two-way ANOVA; Fungus isolate: $F_{4,54}=64.49$, $p<0.001$; moisture: $F_{1,54}=4.25$, $p=0.044$). Females emerging from the soil with the lower moisture level laid significantly more eggs (65.0±7.3 eggs per female) than females emerging from the soil with a higher moisture level (50.7±7.9 eggs per female). Fungus treatments resulted in an efficacy (Abbott's formula) of 73% for the fungi Ifr 531, 68% for Bb 74040 and Ma 714, and 29% for Ifr 97.

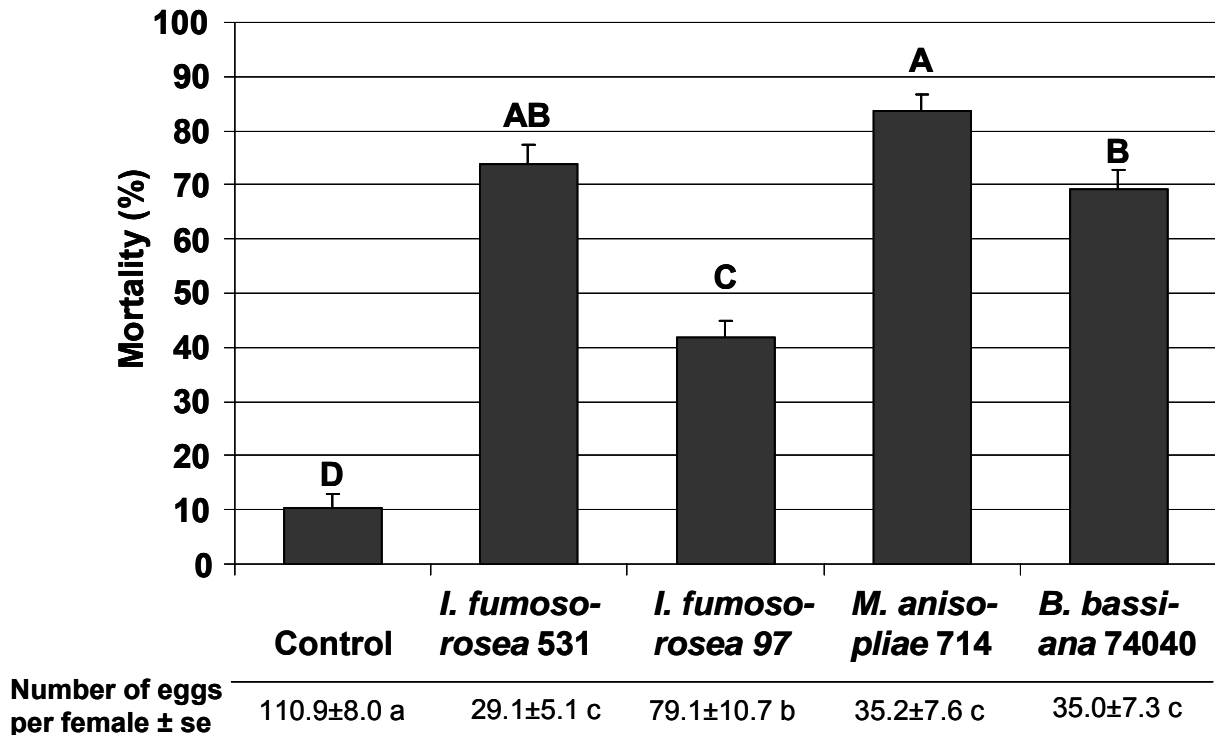

Figure 13: Effects of soil treatments with different fungus isolates on mortality (\pm se) of emerged adult *R. cerasi* (collection site: Hottwil AG, Switzerland). Pooled data over the two moisture levels. Statistical analysis for mortality: Data transformed [$\arcsin\sqrt{x}$]; two-way ANOVA: Fungus isolate: $F_{4,54}=64.49$, $p<0.001$; Tukey HSD-Test $\alpha=0.05$; Statistical analysis for number of eggs per female: two-way ANOVA: Fungus isolate: $F_{4,54}=21.54$, $p<0.001$; Tukey HSD-Test $\alpha=0.05$; different letters show significant differences.

A.3.3. Efficacy of different fungus isolates against larvae of *R. cerasi*

The results of this experiment are given in Table 2. The conidial viability of all fungus isolates exceeded 75% after 48 h of incubation. Conidia did not lose their viability during the handling in the orchard.

No larvae died during the experiment. All larvae pupated normally. Pupae were placed on moist peat eight days after pupation to stimulate fungus outgrowth. The percentage of pupae with signs of mycosis ranged from 4.2% to 20.8%; however, differences between treatments were not significant. In two undamaged pupae (Ifr 531 and Ifr 97), the fungus sporulated inside the undamaged puparium and was not discovered until dissection at the end of the experiment. The rate of mycosis and the rate of pupal mortality without signs of mycosis are given in Table 2. Fungus treatment had no effect on adult emergence. Mortality of adult flies was monitored for 53 days after the first emergence and 21 days after the last emergence, respectively (Table 2). Mortality was highest in the control group. None of the dead flies showed signs of mycosis.

Table 2: Effects of different fungus treatments on survival of *R. cerasi* larvae (collection site Aesch BL, Switzerland).

Fungus isolate	% pupae showing mycosis \pm se ¹	% pupal mortality (without mycosis) \pm se ²	% Emergence \pm se ³	% mortality of adult flies
Control	0.0 \pm 0.0 [n.s.]	8.3 \pm 8.3 [n.s.]	91.7 \pm 8.3 [n.s.]	50.0%
Ifr 531	20.8 \pm 4.2 [n.s.]	8.3 \pm 4.8 [n.s.]	70.8 \pm 4.2 [n.s.]	23.5%
Ifr 97	8.3 \pm 4.8 [n.s.]	0.0 \pm 0.0 [n.s.]	91.7 \pm 4.8 [n.s.]	9.1%
Ifa 954	4.2 \pm 4.2 [n.s.]	4.2 \pm 4.2 [n.s.]	91.7 \pm 8.3 [n.s.]	36.4%
Ma 714	4.2 \pm 4.2 [n.s.]	12.5 \pm 8.0 [n.s.]	83.3 \pm 9.6 [n.s.]	15.0%
Ma 786	8.3 \pm 4.2 [n.s.]	12.5 \pm 4.2 [n.s.]	79.2 \pm 8.3 [n.s.]	5.3%
Bb 74040	4.2 \pm 4.2 [n.s.]	20.8 \pm 4.2 [n.s.]	75.0 \pm 4.8 [n.s.]	5.6%

¹ Kruskal-Wallis-Chi square-test: $\chi^2=10.89$, $df=6$, $p=0.09$; Differences not significant; ² Kruskal-Wallis-Chi square-test: $\chi^2=8.10$, $df=6$, $p=0.23$; Differences not significant; ³ Kruskal-Wallis-Chi square-test: $\chi^2=7.03$, $df=6$, $p=0.32$; Differences not significant.

A.4. Discussion

The results confirm the susceptibility of adult Tephritid flies to entomopathogenic fungi reported by different authors (Garcia et al., 1985; Carneiro & Salles, 1994; Castillo et al., 2000; De La Rosa et al., 2002; Dimbi et al., 2003a; Dimbi et al., 2004; Destefano et al., 2005; Ekesi et al., 2005; Konstantopoulou & Mazomenos, 2005; Yee & Lacey, 2005). All fungus isolates were pathogenic to adult *R. cerasi* from different collection sites in northwestern Switzerland; however, virulence varied considerably. The least pathogenic isolate, *I. farinosa* 954, caused only 4 to 9% mortality five days after treatment, whereas all other isolates showed mortality rates of 17 to 70%. Median survival time for *I. fumosorosea* Apopka 97, *I. fumosorosea* Apopka 97, *M. anisopliae* 714 and *M. anisopliae* 786, as well as for *B. bassiana* ATCC 74040, ranged from four to 10 days after treatment. Thus, biological control of *R. cerasi* within the pre-oviposition period of about 10 days (Boller, 1966b) seems possible.

Of the five fungus isolates evaluated in the first experiment, *B. bassiana* ATCC 74040 and *I. fumosorosea* 531 were the most virulent. The second experiment confirmed the results of the first experiment. Using fewer flies with a wider age spectrum, however, resulted in increased variability of the data. Despite the low conidia viability of *B. bassiana* ATCC 74040 in the second experiment, this fungus isolate had the most pronounced effect on the number of eggs. After two experiments, *I. farinosa* 954 and *M. anisopliae* 786 were abandoned and replaced with the commercial isolate *I. fumosorosea* Apopka 97.

B. bassiana ATCC 74040 showed the greatest efficacy at low concentrations. In spite of its low conidia viability in this experiment, *I. fumosorosea* Apopka 97 also showed good efficacy. In a screening of different fungus isolates against *C. capitata*, Castillo et al. (2000) found no differences between fungus isolates at high concentrations. At low concentrations, however, isolates differed significantly.

Survival time for fungus treated adults of *R. cerasi* was generally shorter for older flies than for young flies. These results are consistent with those of Maniania and Odulaja (1998), who showed that old tsetse flies died earlier from fungus infestation than younger ones. However, Rizzo (1977) and Anagnou-Veroniki et al. (2005) could not detect an age effect for different dipteran species on mortality caused by *B. bassiana* and *M. anisopliae*. In contrast to my

results, Dimbi et al. (2003b) showed that young *Ceratitis sp.* died earlier than older flies after *M. anisopliae* exposure.

No mycosis was observed on dead untreated (control) flies. This proves that no accidental transmission of fungi took place between neighbouring cages. Mycosis was confirmed in more than 80% of all treated flies. All fungus isolates were able to cause mycosis. First signs of fungus outgrowth were often visible 24 hours after incubation of dead flies on moist peat. In both *M. anisopliae* isolates, a distinct mycelium was visible on an average of 28 hours after incubation, for *B. bassiana* ATCC 74040 after 37 hours, for *I. fumosorosea* 531 after 53 hours and for *I. farinosa* 954 after 65 hours. This result is consistent with that of De La Rosa et al. (2002), who observed the fungal mycelium (*B. bassiana*) covering 80% of the body surface of *A. ludens* after 48 hours. Despite the high mortality of flies in *M. anisopliae* 714, the mycosis rate was often low. The mycosis rate for all fungus isolates generally declined during the experiments, indicating that fungus-induced mortality mainly occurs within 10 days after treatment. However, in some cases mycosis was demonstrated in flies that died 30 days post exposure.

No alteration in behaviour of fungus-treated flies was observed during the experiment: flies mated and oviposited normally until shortly before death. In one case a dead female was found with its ovipositor inserted in a fruit. Yee and Lacey (2005) also observed mating and oviposition of *R. indifferens* treated with *M. anisopliae*. They concluded that fungi had “no direct effect on fecundity, but that they indirectly affected it by causing death quickly without making the flies less vigorous”. In my experiments, effects on number of eggs also seemed mainly to be due to the reduced life span of females. In some cases, treated females laid fewer eggs per day. However, this reduction was only significant if the mortality of flies within the first five days after treatment was higher than 50%. In addition, this phenomenon was observed particularly among older flies. This is surprising, as older flies were expected to carry mature, fertilized eggs and as females were observed ovipositing until death.

I. fumosorosea 531 and *B. bassiana* ATCC 74040 significantly reduced egg fertility. Castillo et al. (2000) observed similar reactions for fungus-treated *C. capitata*. These sub-lethal effects were most pronounced among the youngest flies (0-1 day old). In the control, 80% of the eggs hatched within seven to 10 days, which corresponds with the observations of Boller (1966b). Boller (1966b) also stated that egg fertility can decrease due to reduced mating activity. In my experiments, mating occurred frequently in all treatments. Whether the reduced egg fertility depended on female or male fitness was not evaluated. Queseda-Moraga et al. (2006) hypothesize that the reproductive effects of *B. bassiana* and *M. anisopliae* on *C. capitata* were governed mainly by maternal factors.

The conidial viability varied among experiments and fungus isolates. Viability was low in some experiments, especially for *B. bassiana* ATCC 74040 and for *I. fumosorosea* Apopka 97. There is no evident explanation for this variation because experimental conditions were very similar. However, despite the low conidial viability of *B. bassiana* ATCC 74040 and *I. fumosorosea* Apopka 97, these isolates showed good results. Moreover, *B. bassiana* ATCC 74040 showed the best efficacy when conidia viability was high.

The number of conidia per fly was estimated only for the fungus *M. anisopliae* 714, as conidia of this species are best visible due to size, shape and colour, especially in suspensions containing broken hairs and other particles from the fly bodies. Females carried

slightly greater numbers of conidia than males, possibly due to their bigger body size. In some experiments, females seemed slightly more susceptible to entomopathogenic fungi than males, however, differences were not significant. The relevant literature is inconsistent. According to Dimbi et al. (2003b), female *Ceratitis sp.* die earlier from *M. anisopliae* infection than males, whereas Garcia et al. (1984) and Carswell et al. (1998) found no influence of sex on mortality of *C. capitata* and *B. tryoni* after *M. anisopliae* treatment.

Although both treated and untreated flies were observed copulating, it appears that there is no fly-to-fly conidial transmission after application of conidia suspensions to *R. cerasi*. These results are contrary to those observed after the application of dry conidia formulations to *Ceratitis sp.* (Dimbi et al., 2003a), *A. ludens* (Toledo et al., 2007) and *Delia radicum* (Meadow et al., 2000). Transmission might be facilitated by the use of dry conidia rather than conidia suspensions.

Using soil treatments to infect emerging flies has potential. Although the emergence rate was not reduced, flies emerging from treated soil showed increased mortality after 5 days. Yee & Lacey (2005) obtained similar results with *M. anisopliae* against *R. indifferens*. The two levels of soil moisture examined in my experiment (35 and 45% field capacity) had no effect on fly mortality. Based on their experiments with moisture levels of 30% and 13%, however, Yee & Lacey (2005) concluded that adequate moisture is critical for successful infections. Higher moisture levels were chosen for my experiment, as a certain amount of water is necessary to spread the conidia suspension evenly over the soil surface. The reduced oviposition rate in cages with treated soil seemed mainly due to the shorter life span of females. No mycosis was observed on dead flies in the control. This result indicates that the natural occurrence of conidia is too low to cause mycosis in flies during emergence, as the soil obtained from a cherry orchard was not sterilized before the experiment.

Mature L₃ larvae showed only a low susceptibility to fungus infection. All fungus isolates, however, were able to cause mycosis, even if mortality rates were extremely low. Pupation, adult emergence, and fly mortality were not significantly reduced by fungus treatments. As the larvae were dipped for five seconds in a highly concentrated conidia suspension, it is hypothesized that infection rates under natural conditions would be close to zero. This is in accordance with the results of Yee and Lacey (2005), who showed that larvae of *R. indifferens* could not be infected by *M. anisopliae*. However, Ekesi et al. (2002; 2005) demonstrated in laboratory and field studies that L₃ larvae of *Ceratitis sp.* are highly susceptible to *M. anisopliae* and *B. bassiana*: treated larvae pupated normally, but the emergence rate was reduced and the adult mortality rate increased. L₃ larvae of *A. ludens* were found to be highly susceptible to *M. anisopliae* (Lezama-Gutierrez et al., 2000) but not to *B. bassiana* (De La Rosa et al., 2002). I dissected all pupae that failed to emerge within 75 days after incubation without showing signs of mycosis: 45% of these pupae were brown and shrivelled, 35% were healthy, fully developed and bright yellow in colour, in 15% the flies died during emergence, and 5% were parasitized. Natural factors inhibiting emergence therefore exceeded mortality caused by fungus infection.

L₃ larvae, pupae, and adults are the only life stages that can come in contact with entomopathogenic fungi. Eggs and younger larvae develop inside the fruit and are therefore well protected from any environmental impact. Because natural mortality of pupae during diapause is usually high (Boller, 1966b) and fungi were shown to have only low efficacy on

Tephritid larvae and pupae (De La Rosa et al., 2002; Ekesi et al., 2002), control of *R. cerasi* should be focused on adult flies. The results show that adult *R. cerasi* are highly susceptible to entomopathogenic fungi. *B. bassiana* and *I. fumosorosea* caused the highest mortality and significantly reduced the number of eggs. The following strategies for field application are now under consideration: Soil treatments with entomopathogenic fungi focused on teneral adults (Yee & Lacey, 2005), the use of autoinoculative devices for attract-and-kill strategies (Dimbi et al., 2003a), and on-plant applications of entomopathogenic fungi as mycoinsecticides.

Part B – Soil netting to evaluate the general efficacy of soil treatments for controlling *R. cerasi*

B.1. Introduction

R. cerasi is the only pest insect that makes a treatment of cherry fruit necessary. All other insect pests of cherries (*Operophtera brumata*, *Argyresthia pruniella*, *Myzus cerasi*) can be easily controlled in the early spring by pre-bloom applications. A control method for *R. cerasi* by soil applications seems attractive in terms of producing residue-free cherries. In addition, the application of non-systemic insecticides is often ineffective in tall standard trees due to unsatisfactory coverage of the upper canopy. Extensively managed standard trees (height of first branches 1.8 m, planting density 50 to 80 trees per hectare) and standard trees in semi-intensive systems (height of first branches 1.2 m, planting density 200 to 500 trees per hectare) are still common in Switzerland for the production of cherries for distillery and canning industries. With the use of disease-tolerant varieties suited for mechanical harvest, the cherry fruit fly remains the only limiting factor for cost-effective growing of these trees. From a landscape and nature conservation standpoint, it is desirable to preserve these traditional trees, and this is only possible by providing economically sound production methods. Therefore, new strategies are needed to lower the infestation level of *R. cerasi* below the market tolerance level for cherries for the distillery and canning industries (6%).

Because *R. cerasi* pupae spend more than 10 months per year in the soil (Boller, 1966b) and because the area of pupation is strictly limited to the surface directly under the canopy of infested trees (Wiesmann, 1933b), the possibility of soil treatments is appealing (Wiesmann, 1936). In the past, soil treatments were considered by different authors: Frank (1891) suggested soil cultivation in order to bury the pupae more deeply, whereas Mik (1898) recommended compression of the soil surface prior to adult emergence. However, according to the results of Thiem (1934), a mechanical treatment of the soil surface is not sufficient. He suggested using creosote on larvae shortly before pupation and Tetrachloroethane to kill the pupae. Wiesmann (1934b) tested a broad range of different means (such as arsenic compounds, naphthalene, dichlorobenzene, nicotine, and kerosene) to control emerging flies or pupae in the soil. He stated that kerosene treatments completely prevented emergence, but that one out of three experimental trees died and another third was badly damaged. When organo-chemical insecticides such as DDT became available in the 1950s (Roessler, 1989), the research on soil treatments was abandoned. Quick-acting organophosphorus insecticides (Dimethoate and Fenthion) were registered shortly thereafter in 1965. Currently, Dimethoate is still in use, whereas Fenthion is no longer registered in most European countries because of its high avian toxicity. With the current discussion on the banning of Dimethoate and with the growing knowledge on microbial biological control agents, soil treatments are again being considered. Laboratory experiments demonstrated an efficacy of soil treatments with entomopathogenic nematodes (Gazit et al., 2000; Yee & Lacey, 2002; Köppler et al., 2005a; Kuske et al., 2005; Toledo et al., 2005) or fungi (Garcia et al., 1989; Lezama-Gutierrez et al., 2000; Ekesi et al., 2003; Destefano et al., 2005; Yee & Lacey, 2005) on Tephritid flies.

However, soil treatments can only be effective, if the migration of flies between differently treated orchards is low. Thiem (1934) hypothesized that most of the flies migrate from near-

by *Lonicera* plants to the cherry trees. However, dislocation of flies by wind was considered to be more important than active flight ability (Thiem, 1954). According to Wiesmann (1934b), flies rarely migrate more than 300 m from their emergence sites and migration is only induced in cases of insufficient supply of host fruit or after harvest. This observation is supported by Katsoyannos et al. (1986), who stated that flies move from early ripening varieties to later ripening varieties and from there on to *Lonicera*, driven by oviposition pressure of females. Detailed experiments on dispersal behaviour of *R. cerasi* were conducted within the framework of the “sterile-males-technique”: Flight studies in the laboratory showed that flies are capable of flying more than one kilometre in 24 hours (Remund & Boller, 1975). Under field conditions, however, 82% of marked and released flies were recaptured at a distance of less than 100 m, only 0.7% of the flies were recaptured at a distance of 500 m and none at a distance of 600 m (Boller, 1969). Flights over long distances were only observed across open fields with direct intervisibility to the next tree (Boller & Remund, 1980). Reviewing the literature on dispersal of *R. cerasi*, Fletcher (1989b) concludes: “As fruit are normally available in the immediate vicinity of the emergence sites there is no need for the flies to migrate any major distance in search of hosts. [...] Adult activity takes place on hosts and nearby non-host trees and movements are fairly limited. [...] In *Rhagoletis* sp. movements are generally non dispersive. [...] However, in the absence of hosts or in response of stimuli indicating heavy fruit infestation, flight activity and duration increases, resulting in a significant movement between habitats.” However, all studies cited above were conducted in landscapes with some scattered, standard trees. No data are available on dispersal and migration behaviour of *R. cerasi* within orchards.

In order to evaluate the dispersal and flight behaviour of *R. cerasi* within a compact orchard of semi-intensively managed standard trees and to examine the general potential of soil treatments, experiments using netting to cover the soil were conducted in two orchards. In addition, the effect of the soil covering was evaluated under two single standard trees.

B.2. Materials & methods

The experiments were conducted in three commercial, organically managed orchards (Sissach 1, Möhlin 1 and Möhlin 2) in northwestern Switzerland in 2005 and 2006. Orchard locations are given in Annex I.

The Sissach 1 orchard was planted in 1968 and consisted of 82 cherry trees of different varieties (see Annex II – Figure 1 for details). Trees were five metres tall and normally yielded approximately 15 kg cherries each. The orchard was arranged in five rows (replicates) with 20 trees per row and a row length of 100 m. An inspection of infestation rates during the preceding years indicated that the distribution of *R. cerasi* was homogenous within the orchard, with a tendency toward slightly higher infestation rates in the centre of the orchard. In the middle of each row, 50 running metres of the soil under the tree canopies were covered with a fine mesh netting (0.8 mm mesh width) before the beginning of the emergence period on 18 May 2005. On each side of the rows, 25 running metres were left uncovered to provide an untreated control. The edges of the netting were buried (Figure 14) to prevent flies from escaping. However, not all holes could be closed completely around the trunk (Figure 14). Details on cherry varieties and experimental design are given in Annex II – Figure 1. Fly activity was monitored using one yellow sticky trap (Rebell® amarillo, Andermatt Biocontrol AG, Grossdietwil, Switzerland) per tree. The netting was removed on

6 July 2005. The yellow sticky traps remained on the trees until 14 July 2005. The number of flies per trap was counted at weekly intervals. To summarize the results, three different time periods were considered: (1) The cumulative number of flies per trap over the whole period of net covering (total captures; 18 May until 6 July 2005). (2) The number of flies per trap after removal of the netting (captures after removal; 7 July until 14 July 2005) was examined to determine, whether flies can survive under the net cover. (3) The cumulative number of flies caught until two weeks before removal of the netting (early captures; 18 May until 22 June 2005). The last period was chosen because migration of *R. cerasi* is mainly induced by high oviposition pressure (Katsoyannos, 1979). If mature females do not find enough uninfested cherries for oviposition, they readily move to other trees. An increased migration of flies was expected because the trees in the Sissach 1 orchard yielded no fruit in 2005 due to a detrimental attack of *Operophtera brumata* in early spring. The fruit infestation could therefore not be evaluated in this experiment.



Figure 14: Installation of the soil covering netting in the Sissach 1 orchard on 18 May 2005.

The Möhlin 1 orchard consisted of 25 cherry trees of different varieties (see Annex II – Figure 2 for details). Trees were five metres tall and yielded 5 to 10 kg cherries each. The orchard was arranged in three rows with a row length of 65 to 90 m. An inspection of infestation rates during the preceding years indicated that the flight activity of *R. cerasi* in the centre of the orchard was comparable to the flight activity at the margins of the orchard. In the middle of each row, 40 running metres of the soil under the tree canopies were covered with a fine mesh netting (0.8 mm mesh width) before the beginning of the emergence period on 30 May 2006. On each side of the rows, 12 to 24 running metres were left uncovered to provide an untreated control. The edges of the netting were buried to prevent flies from escaping. The soil under all other cherry trees in a perimeter of 50 m around the experimental orchard was covered in a similar manner. Details on cherry varieties and experimental design are given in Annex II – Figure 2. One yellow sticky trap (Rebell® amarillo) per tree was installed on 02 June 2006. The netting was removed on 4 July 2006; the yellow sticky traps remained until 11 July 2006. The number of flies per trap was counted in weekly intervals. To summarize the results, the same time periods as described above were considered: Total captures of flies (02 June until 04 July 2006), captures after removal of netting (05 July until 11 July 2006), and early captures (02 June until 20 June 2006). A sample of 50 cherries per tree was taken according to the harvesting time of the different varieties on 17 June 2006 (variety Magda), 23 June 2006 (variety Star), 03 July 2006

(varieties Langstieler and Dolleseppler) and on 04 July 2006 (variety Kordia). The cherries were dissected under the binocular microscope to determine the exact infestation level of *R. cerasi* with eggs, larval instars and damaged fruit, abandoned by larvae going into pupation.

The third experiment was conducted under two single standard cherry trees (Möhlin 2 orchard, Figure 15) in 2005. Trees were ten metres tall and yielded 20 kg cherries each. The distance between these two trees was 10 m. The distance to the nearest infested cherry trees without netting (control) was 100 m. The two experimental trees and the two control trees were approximately the same size and had similar infestation levels during the preceding years. Details on the locations of these trees are given in Annex I. The netting was put in place on 14 May 2005. The net edges were buried. One yellow sticky trap was placed in each of the two experimental trees as well as in the two control trees. The netting was removed shortly before harvest on 22 June (tree 1) and on 03 July 2005 (tree 2). Traps were removed on 3 July 2005. Flight activity was compared based on numbers of total captures (14 May until 22 June 2005).



Figure 15: Experimental trees (Möhlin 2 orchard).

With the simple experimental design of the third experiment, a statistical analysis was not possible for these data. In the two other experiments, rows were treated as replicates. Means per plot were calculated (see Annex II – Figures 1 and 2 for experimental design details). Normality of data and homogeneity of variance were tested before performing a one-way ANOVA [treatment; Data from Sissach 1 orchard] or a two-way ANOVA [treatment, cherry variety; data from Möhlin 1 orchard]. Means were compared by Tukey HSD post hoc tests ($\alpha=0.05$). Unless mentioned otherwise, the data presented in the figures and the text are means with standard errors. The following treatments were compared: (1) control, without covering; (2) border area of netting (less than 10 m distance to the border of the netting); (3) centre of netting. JMP version 5.0.1.2. was used for all statistical analyses.

B.3. Results

The climatic conditions are given in Annex III – Figure 2. The flight period in the Sissach 1 orchard started shortly after installing the netting and reached a peak during the warm and sunny period from 14 June to 28 June 2005 (Figure 18). Over the whole flight period only 4.5 flies per trap were caught in the control plots. A higher flight activity was observed in the

Möhlin 1 orchard in 2006. Flight activity was seven times higher than in the Sissach 1 orchard in 2005: over the whole flight period, 32.4 flies per trap were caught in the control plots. The flight period started shortly after installing the netting and reached a peak during the warm, sunny period from 07 June to 14 June 2006 (Figure 19).

The total number of flies per trap (total captures) and flies caught until two weeks before removal of the netting (early captures) in both experiments are given in Figure 16. The netting significantly reduced the number of flies and showed an efficacy of 76 to 80% (Abbott's formula, (Abbott, 1925)). No differences were found between the border (less than 10 m from the control) and the centre of the netting.

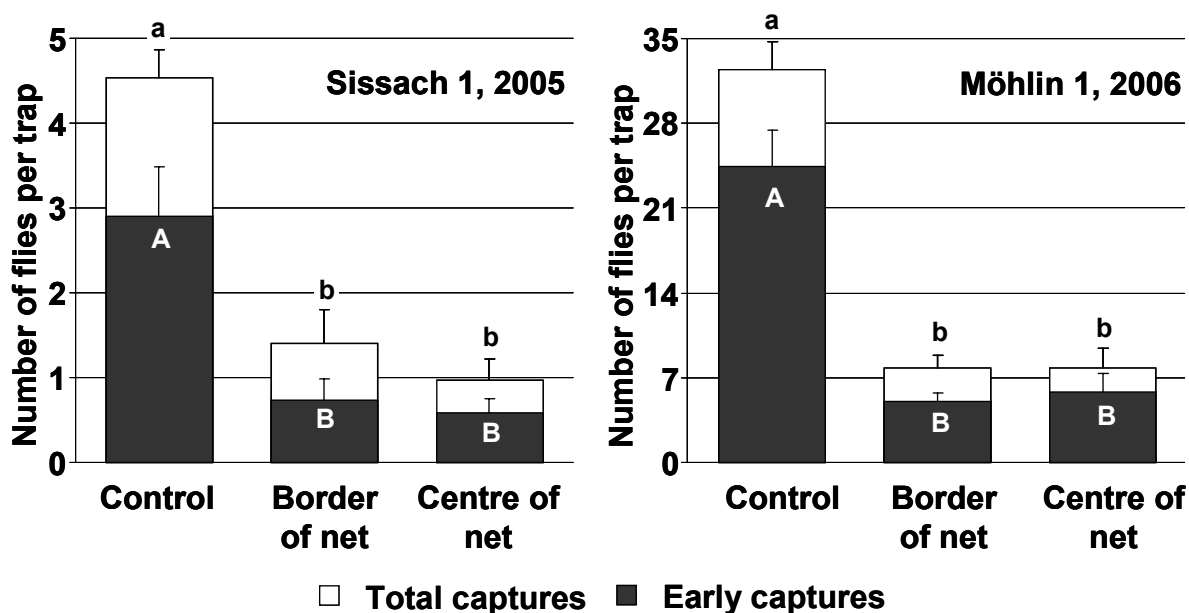

Figure 16: Effects of soil covering with netting on average number of *R. cerasi* (\pm se) on yellow sticky traps in the Sissach 1 orchard (2005) and the Möhlin 1 orchard (2006). Statistical analysis for the Sissach 1 orchard: one-way ANOVA: total captures: $F_{2,12}=34.99$, $p<0.001$; early captures: $F_{2,12}=11.50$, $p=0.001$; Statistical analysis for the Möhlin 1 orchard: two-way ANOVA [treatment, cherry variety]: total captures: treatment: $F_{2,9}=118.46$, $p<0.001$, variety: $F_{4,9}=4.70$, $p=0.03$; early captures: treatment: $F_{2,9}=40.10$, $p<0.001$, variety: $F_{4,9}=3.21$, $p=0.07$; Tukey HSD-Test $\alpha=0.05$; different letters show significant differences.

Cherry variety had a significant effect on total captures of flies in the experiment in the Möhlin 1 orchard: the total number of flies per trap in the variety Magda (27.0 ± 14.0 flies per trap) was significantly higher than in the variety Dolleseppler (11.5 ± 6.8). The total captures in all other varieties were not significantly different from those in the varieties Magda or Dolleseppler (Star: 14.9 ± 6.4 ; Langstieler: 16.2 ± 9.2 ; Kordia: 18.2 ± 6.3). No significant effects of cherry variety on number of early captures or on infestation level at harvest (two-way ANOVA [treatment, cherry variety]: variety: $F_{4,9}=1.36$, $p=0.32$) were found. The infestation level at harvest, however, tended to be highest in the varieties Star (11.3% infested fruit) and Dolleseppler (8.0%), and lowest in the variety Magda (2.0%). The variety Kordia showed an infestation level of 4.0%, the variety Langstieler 6%. The treatment had a significant effect on the infestation level (Figure 17): In the control plots, 12.5% of the cherries were damaged by *R. cerasi* larvae. With an infestation level of 4.5%, an efficacy of 64% was achieved for the trees at the border of the netting. In the centre of the netting 1.2% of fruit were infested, indicating an efficacy of 91% (Abbott's formula).

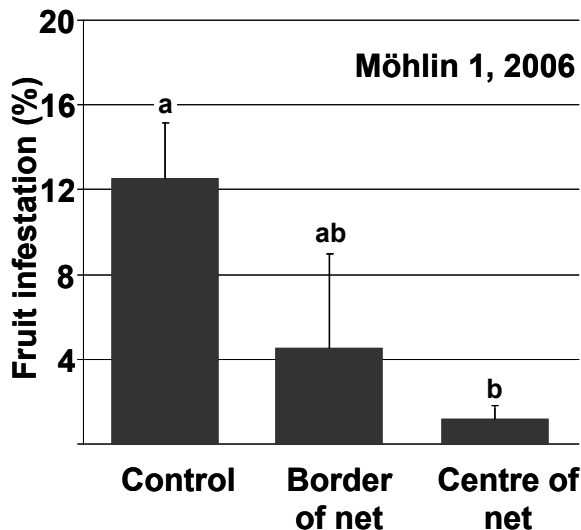

Figure 17: Effects of soil covering with netting on percentage infestation rate of cherries with *R. cerasi* larvae (\pm se) in the Möhlin 1 orchard (2006). Statistical analysis: two-way ANOVA [treatment, cherry variety]: treatment: $F_{2,9}=6.61$, $p=0.02$, variety: $F_{4,9}=1.36$, $p=0.32$; Tukey HSD-Test $\alpha=0.05$; different letters show significant differences.

The flight activity of *R. cerasi* over the whole experimental period in the Sissach 1 and Möhlin 1 orchards is given in Figure 18 and Figure 19. Flight activity was mainly influenced by climatic conditions. Curves for the different treatments showed similar patterns of activity. No change in activity was found toward the end of the flight period. After the netting was removed, however, the captures in the treated plots increased. Differences in numbers of flies per trap between treatments after removal of the netting were not significant (statistical analysis for Sissach 1 orchard: one-way ANOVA: $F_{2,12}=2.49$, $p=0.12$; Statistical analysis for Möhlin 1 orchard: two-way ANOVA [treatment, cherry variety]: treatment: $F_{2,9}=0.73$, $p=0.51$, variety: $F_{4,9}=0.91$, $p=0.50$).

In the third experiment, the flight period started about 10 days after installation of the netting in the Möhlin 2 orchard in 2005 and reached a peak during the warm and sunny period from 15 June to 22 June 2005 (Figure 20). Netting 1 was removed on 22 June 2005 in order to harvest the cherries. After removal of netting 1, a strong increase of flight activity was found in this tree (Figure 20). The second net was removed on 03 July 2005. Net covering reduced the total captures by 87% (Abbott's formula; control 178.5 ± 15.5 flies per trap; netting: 23.5 ± 3.5 flies per trap). Fruit samples taken on 29 June 2005 from the trees "Control 1" and "Netting 1" trees showed infestation rates of 70.9% and 20.0%, respectively, which corresponds to an efficacy of 72% (Abbott's formula).

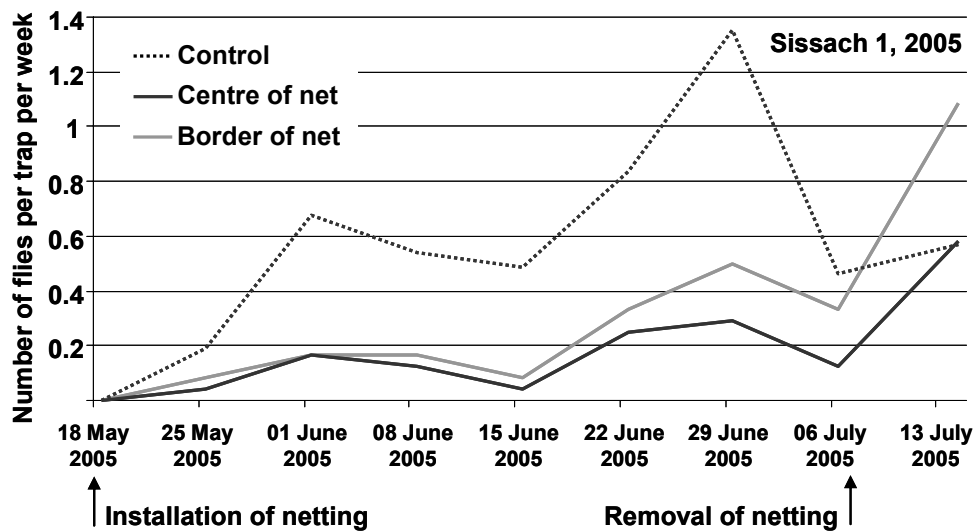

Figure 18: Flight activity of *R. cerasi* in the Sissach 1 orchard in 2005.

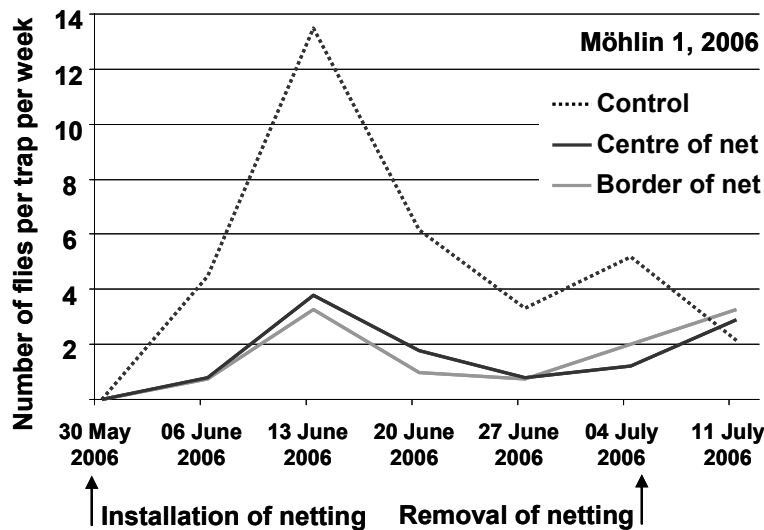

Figure 19: Flight activity of *R. cerasi* in the Möhlin 1 orchard in 2006.

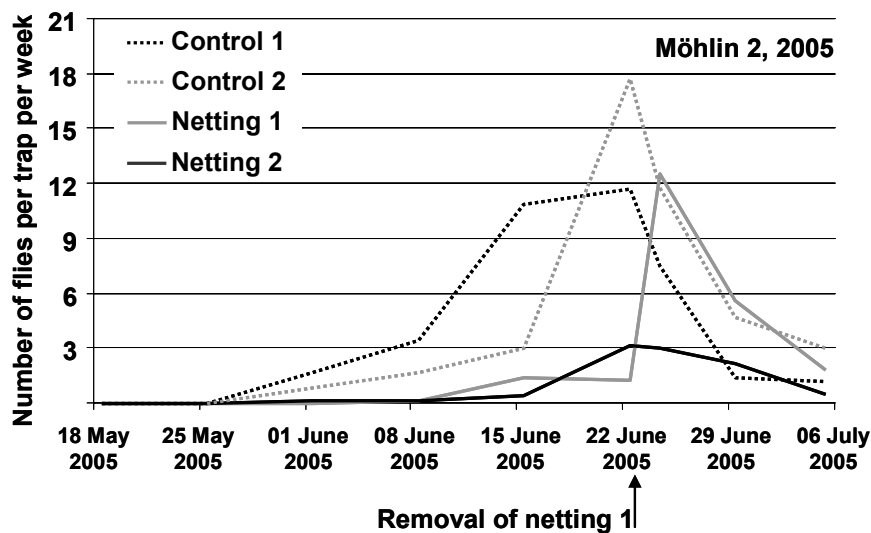

Figure 20: Flight activity of *R. cerasi* in the Möhlin 2 orchard in 2005.

B.4. Discussion

Covering the soil under the tree canopies reduced the flight activity of *R. cerasi* by 75 to 80%. This effect was also observed at the border of the netting in the immediate vicinity of the control trees without soil covering. The results were obtained from two experiments in two years and in different locations with different flight intensities of *R. cerasi*. No change in activity was found toward the end of the flight period in either experiment, indicating that mature females did not show an increased migration. The number of flies per trap was mainly influenced by weather conditions: activity peaks were observed during sunny and warm periods. Cherry fruit fly dispersal within a compact orchard is therefore considered to be low. Throughout the whole flight period, a large number of flies seemed to remain in the tree under which they emerged. This observation is surprising, as different authors (Wiesmann, 1934b; Katsoyannos, 1979) have shown an increased migration in the event of fruit shortage or after harvest. However, even the total lack of fruit in the Sissach 1 orchard or the early harvest of the variety Magda in the Möhlin 1 orchard did not increase migration within the orchard. The captures in the treated plots increased after removal of netting, which suggests that flies survived under the netting.

Whether the few flies found on the traps over covered soil escaped through holes around the trunk or migrated from neighbouring trees could not be determined. The combination of this strategy with perimeter trapping of immigrating flies using sticky traps and baits (Prokopy et al., 2003), might even improve the efficacy of soil treatments of entire orchards.

Fruit infestation was reduced to a level below the 6% economic threshold for distillery and processing-industry cherries. At the borders of the netting, the infestation level of 4.5% still exceeded the maximum tolerance of 2% infested fruit for fresh market quality, whereas this target was achieved (1.2% infested fruit) in the centre of the netting. The discrepancy observed between the flight activity monitored by traps and fruit infestation in the Möhlin 1 orchard (highest flight activity but lowest infestation level in the variety Magda) might have been due to the differences in yield obtained from the different varieties. With approximately 600 cherries per tree, the yield was very low for the varieties Star and Kordia. A low flight activity was apparently enough to cause high infestation levels in these varieties. Similar observations were made by Fimiani (1989).

An 87% reduction of flight activity was observed in the experiment conducted on two single standard trees. Based on infestation level, the netting showed an efficacy of 72%. However, 20% infested fruit is much too high to meet the market demands. A soil treatment is therefore not sufficient for single trees growing in a landscape with many scattered, unmanaged and heavily infested cherry trees. In such cases, area-wide management of *R. cerasi* or the additional application of traps and baits should be considered.

In conclusion, soil treatments are a promising strategy for controlling *R. cerasi* in orchards. For commercial cherry production, however, the use of netting is rather expensive and labour-intensive. Considering the good laboratory results with entomopathogenic fungi (see part A), the development of a field application strategy for soil treatments with entomopathogenic fungi seems promising. Nevertheless, some cherry growers were convinced by these results and started to use netting to control the flies in 2007. Because the flies can survive for a long time under the netting it is advisable to bury the edges completely and to leave the netting in place until harvest.

Part C – Semi-field experiments to evaluate the efficacy of soil treatments with entomopathogenic fungi

C.1. Introduction

Entomopathogenic fungi have a world-wide distribution as part of the natural soil flora (Samuels et al., 1989; Keller et al., 2003; Meyling & Eilenberg, 2006) and can easily be isolated using selective media (Liu et al., 1993) or bait methods (Zimmermann, 1986). Spores can survive for long periods in soil habitats (Madelin, 1966; Wraight & Ramos, 2002; Enkerli et al., 2004). Therefore, soil is considered to be a reservoir for these pathogens (Hajek & Leger, 1994). Because orchards provide long-term stable habitats, Cross et al. (1999) hypothesize that populations of entomopathogenic fungi in orchard soil are likely to be large. Keller et al. (2003) showed that soils from orchards in northeastern Switzerland tended to contain higher densities of *M. anisopliae* than meadows in the same region and with similar soil types. The use of entomopathogenic fungi in their natural soil environment, either by exploiting naturally occurring populations or by the application of new agents, is considered to be promising for pests that spend at least part of their life cycles in soil (Cross et al., 1999). Organically managed soil in particular might be a suitable habitat for insect pathogenic fungi: The absence of synthetic pesticides as well as the use of organic fertilizers might provide favourable conditions for insect pathogenic fungi (Klingen et al., 2002). It is known that the density of *B. bassiana* in orchard soils (Marjanska-Cichon et al., 2005) and on phylloplanes of hedgerow plants (Meyling & Eilenberg, 2006) is lower in spring than in autumn. Therefore, a spring application of entomopathogenic fungi might increase the activity of entomopathogenic fungi in the soil during the emergence period of cherry fruit flies.

As shown in part B, soil treatments can provide effective control of *R. cerasi*. Because the use of netting is rather expensive and labour-intensive, soil treatments with entomopathogenic fungi are considered to be an easier and less time-consuming alternative. The previous laboratory experiments (part A) showed that emerging flies could be infected with entomopathogenic fungi by soil treatments with conidia suspensions. Based on these results, soil treatments using the fungus isolates *M. anisopliae* 714, *B. bassiana* ATCC 74040 and *I. fumosorosea* Apopka 97 were conducted in 2006. The commercial products Naturalis-L and PreFeRal®WG as well as a conidia suspension of the fungus isolate *M. anisopliae* 714 were applied to the soil shortly before the emergence period of *R. cerasi*. *B. bassiana* ATCC 74040 and *M. anisopliae* 714 formulated on barley grains were tested in 2007. Flies were caught after emergence and brought into the laboratory to assess life span, fecundity, mortality rates and rate of mycosis. The aim of these semi-field experiments was to estimate the potential of soil treatments with entomopathogenic fungi for controlling emerging flies.

C.2. Materials & methods

C.2.1. Experiments in 2006

The trials in 2006 were conducted in orchards Aesch and Eptingen. Orchard locations are given in Annex I.

The orchard in Aesch consisted of 76 cherry trees, of which nine trees of the variety Star, nine trees of the variety Langstieler and nine trees of the variety Schauenburger were included in the experiment. The 26 year-old trees were seven to 10 metres tall and yielded 15 to 20 kg cherries each. The cherries in this orchard had not been harvested for more than five years. The experiment was arranged in a randomized block design with six replicates. The soil type was a loamy clay soil (35% clay, 46% silt, 2% organic matter). Details on experimental design are given in Annex II – Figure 3.

The orchard in Eptingen consisted of 26 cherry trees of the varieties Dolleseppler (8 trees), Langstieler (9 trees), Schauenburger (7 trees), and Rote Lauber (2 trees, not included in the trial). The 30 year-old trees were five metres tall and yielded approximately 20 kg cherries each. The orchard was arranged in six rows with two to eight trees at intervals of 7 to 14 m in each direction. The trial was arranged in a randomized block design with six replicates. The soil type was a loamy clay (47% clay, 26% silt, 5% organic matter). Details on experimental design are given in Annex II – Figure 4.

The products Naturalis-L (Lot no. 6001 14/03/06; concentration 2.3×10^7 CFU ml⁻¹) and PreFeRal®WG (Lot no. 52806.2; concentration 2×10^9 CFU g⁻¹), as well as a conidia suspension of *M. anisopliae* 714 (1×10^8 conidia ml⁻¹ with 0.013% Tween 80) were applied in both experiments. On the south side of each tree, 2.5 m² of soil were treated with 10 litres of water containing 3×10^9 CFU using a watering can. CFU concentrations for the products were adjusted by dilution with tap water according to the concentrations given in the package instructions (130.4 ml Naturalis-L per 10 l; 1.5 g PreFeRal®WG; 30 ml of conidia suspension of *M. anisopliae*). Control plots were treated with water. In the Aesch orchard, the first treatment was applied on 16 May 2006. Shortly after application, it started to rain (total precipitation: 7 mm). A second treatment using the same concentrations was applied on 1 June 2006. After this treatment, additional water (10 l per plot) was used to wash the conidia into the soil. The first treatment in the Eptingen orchard was applied on 08 June 2006. After this treatment additional water (10 l per plot) was used to wash the conidia into the soil.

Yellow sticky traps were used to monitor flight period and flight activity. Photo-electors (area 2 m², height 1.1 m, made from fine-mesh netting; see Annex II – Figure 4 for details) were used to catch emerging flies. Photo-electors were installed immediately after the first treatment. The catching containers on top of the electors contained a water supply. All photo-electors were checked daily. Flies were removed from the catching containers and brought to the laboratory. The electors were removed on 20 June 2006 in Aesch and on 23 June 2006 in Eptingen.

In the laboratory, the flies were kept in small plastic cages (3 cm diameter x 12 cm height) containing a water supply and honey under 16 h L : 8 h D at a light intensity of 3000 lux and at 23°C (day) / 17°C (night) and a relative humidity of 65%. Dead flies were placed on moist peat in order to confirm mycosis. Mortality and mycosis were monitored until 08 July 2006.

Statistical analysis was conducted using JMP version 5.0.1.2.. Normality of data and homogeneity of variance were tested before performing an ANOVA. If necessary, data were transformed. Data were analysed by one-way ANOVA [treatment] or two-way ANOVA [treatment, cherry variety]. Means were compared using Tukey HSD post hoc tests ($\alpha=0.05$).

Unless mentioned otherwise, the data presented in the tables and the text are means with standard errors.

C.2.2. Experiment in 2007

In 2007, the experiment was conducted in a meadow in Frick. The soil type was a loamy clay (54% clay, 28% silt, 4% organic matter). Each treatment was applied to six experimental plots of 1 m² size. Plots were arranged in a long row in a randomized block design. Distance between plots was 1.3 m. Details on experimental design are given in Annex II – Figure 5.

M. anisopliae 714 and *B. bassiana* ATCC 74040 formulated on barley grains were used for the experiment. Barley grains inoculated with *M. anisopliae* were obtained from Eric Schweizer AG (Thun, Switzerland). *B. bassiana* ATCC 74040 from the product Naturalis-L was formulated on barley grains according to the following procedure: Naturalis-L was spread-plated on semi-selective medium (see part A for composition). Single colonies were transferred to PDA (potato dextrose agar, CM139, Oxoid Ltd., Basingstoke, UK). A liquid medium with the following composition was prepared: 40 g corn steep (Solulys®AST, Roquette, Lestrem, France), 4.52 g KH₂PO₄ (product no. 60220, Fluka, Buchs, Switzerland) and 7.6 g Na₂HPO₄ (product no. 6580, Merck-Schuchardt, Hohenbrunn, Germany) dissolved in one litre distilled water; another litre of water containing 60 g of sugar was added after autoclaving both solutions separately at 120°C for 20 minutes. The liquid medium was inoculated with mycelium and conidia from the PDA plates. Liquid cultures were shaken at 100 rpm at 22°C for eight days. Barley grains were obtained from the company Eric Schweizer AG (1.3 kg of grains per plastic bag) and 250 ml water was added to each bag. Bags with grains were autoclaved twice in 24 h intervals. 100 ml of liquid culture were poured into each bag. Inoculated barley grains were incubated at 22°C and 70% relative humidity for 62 days and kept in cold storage for one week prior to application. To evaluate the quality of the formulated products, barley grains from both fungus isolates were placed on moist peat until sporulation. Conidia viability was evaluated by spread-plating the conidia onto water agar plates (Agar No. 1; LP0011, Oxoid Ltd., Basingstoke, UK; 15 g l⁻¹). Plates were incubated at 20°C. Percentage germination after 24 and 48 hours was determined by counting the number of germinated conidia per 100 conidia under the microscope (312.5x magnification) in at least three separate areas per plate. Conidia were considered to have germinated if the germ tube was longer than the diameter of the conidium.

Soil treatments were applied on 28 March 2007. The soil was perforated with 400 to 450 holes m⁻² (diameter of holes 0.8 cm; 4 to 5 cm deep). 100 g of fungus-inoculated barley grains were evenly distributed over each plot and brushed into the holes with a wire-tooth rake. Forty *R. cerasi* pupae were placed in small nylon gauze bags (upper side of the bags was open to allow the flies to exit) and buried at a depth of 3 cm in the middle of each plot. The pupae were field collected in Sissach and Eptingen in 2006. Silica sand (3 kg) was scattered over each plot to close the holes. On 2 May 2007 catching containers (diameter 9 cm; height 12 cm) were placed directly over the depot of pupae to catch the emerging flies. Flies were removed daily from the catching containers and brought to the laboratory. The catching containers were removed on 1 June 2007. In the laboratory, the flies were maintained under 16 h L : 8 h D at a light intensity of 3000 lux and at 23°C (day) / 17°C (night) and a relative humidity of 65% in clear round plastic cages (10 cm diameter x 25 cm height). The flies were provided with water and food strips (4/1/4 mixture of sucrose, yeast

hydrolysate as described in part A). Fly mortality was monitored until 11 June 2007. Dead flies were placed on moist peat to confirm mycosis.

Statistical analysis was conducted using JMP version 5.0.1.2.. Normality of data and homogeneity of variance were tested before performing an ANOVA. If necessary, data were transformed. Data were analysed by two-way ANOVA [treatment, origin of pupae]. Means were compared using Tukey HSD post hoc tests ($\alpha=0.05$). Unless mentioned otherwise, the data presented in the figures and the text are means with standard errors.

C.3. Results

C.3.1. Experiments in 2006

Climatic conditions and flight period of *R. cerasi* in 2006

Climatic conditions are given in Annex III – Figure 3. Flies began emerging on 22 May 2006 in the Aesch orchard. On this date, the first flies were caught in the photo-electors as well as on the yellow sticky traps. During the following 10 days, only nine flies were caught in the 24 photo-electors. The cool and overcast weather reduced the activity of flies. Flight activity on yellow sticky traps increased with the warmer weather in the second week of June (9 to 16 June); the number of flies in the catching containers of the photo-electors, however, remained at a low level. A second peak of flight activity was observed between 27 and 30 June.

In the Eptingen orchard, the first flies were caught on 8 June 2006. On this date, the soil was treated and the photo-electors were installed. On the following day, two flies were caught in the photo-electors. Emergence remained high during the warm, sunny period until mid-June, with 6 to 26 flies caught per day in the 24 photo-electors. Peak emergence was observed between 10 and 14 June 2006. However, the sunny weather with a constant breeze dried the soil. The first fissures in soil surface were observed on 10 June. Emergence declined after 18 June. Monitoring of emergence ended on 23 June. Peak flight activity was observed during the same period (10 and 14 June 2006). However, a second peak flight activity occurred around 26 June. On the Rebell® traps considerable flight activity was observed until mid-July.

Emergence, mortality and mycosis of flies

Soil treatments did not affect emergence (number of flies captured in catching containers of photo-electors; Table 3). On average, 1.13 flies per replicate were caught in the Aesch orchard, 5.29 flies per replicate were caught in the Eptingen orchard. Cherry variety had a significant effect on the number of flies in the Eptingen orchard (two-way ANOVA: treatment: $F_{3,18}=0.18$, $p=0.91$; variety: $F_{2,18}=3.83$, $p=0.04$; Tukey HSD-Test $\alpha=0.05$). Significantly more flies were caught under trees of the variety Langstieler (10.22 ± 4.66 flies per replicate) than under the varieties Dolleseppler (1.63 ± 0.53) and Schauenburger (3.14 ± 1.01).

Due to the low number of flies obtained in the Aesch orchard, a statistical analysis of mortality and mycosis data was not possible. High mortality was observed in flies from the control plots in the Eptingen orchard. Fungus treatments did not significantly increase mortality (Table 3). *B. bassiana* and *M. anisopliae* were able to induce mycosis in flies

emerging from treated soil. No mycosis was found in flies emerging from soil treated with PreFeRal®WG.

Table 3: Results of soil treatments with Naturalis-L, PreFeRal®WG and conidia suspensions of *M. anisopliae*.

Year / Orchard	2006 / Aesch	2006 / Eptingen
Average number of flies per photo-elector (emergence)		
Control	0.67±0.49	3.17±1.67
Naturalis-L	1.00±0.37	3.00±0.73
PreFeRal®WG	2.17±1.08	7.00±4.63
<i>M. anisopliae</i> 714	0.67±0.49	8.00±6.22
Statistical analysis (data transformed: $[\log_{10}(x+1)]$)	two-way ANOVA [treatment, variety]: treatment: $F_{3,18}=0.90$, $p=0.46$; variety: $F_{2,18}=0.33$, $p=0.72$	two-way ANOVA [treatment, variety]: treatment: $F_{3,18}=0.18$, $p=0.91$; variety: $F_{2,18}=3.83$, $p=0.04$
% Mortality of flies (absolute number of dead flies*)		
Control	0.00±0.00 (0)	66.94±15.03 (13)
Naturalis-L	75.00±14.43 (4)	67.33±13.09 (11)
PreFeRal®WG	45.24±23.21 (4)	58.89±19.58 (34)
<i>M. anisopliae</i> 714	16.67±16.67 (1)	94.12±4.18 (43)
Statistical analysis (data transformed: $[\arcsin\sqrt{x}]$)	small sample size: no statistical analysis	one-way ANOVA [treatment]; treatment: $F_{3,19}=1.21$, $p=0.33$;
Absolute number of flies showing mycosis* (% of flies showing mycosis)		
Control	0	1 (7.7%)
Naturalis-L	2	5 (45.5%)
PreFeRal®WG	0	0 (0%)
<i>M. anisopliae</i> 714	0	14 (32.6%)
Statistical analysis	small sample size: no statistical analysis	small sample size: no statistical analysis

* Cumulative over all replicates

C.3.2. Experiments in 2007

Climatic conditions and flight period of *R. cerasi* in 2007

Climatic conditions are given in Annex III – Figure 4. Soil treatments were applied on 28 March 2007 on a wet soil. During the following five weeks until the beginning of emergence (7 May 2007), the weather was very warm and sunny, with no precipitation. On 16 April, the soil was found to be dry to a depth of 12 cm; on 23 April the zone of aridity had increased to a depth of 23 cm. However, shortly before the emergence period (5 May) heavy rains occurred and completely drenched the soil. The soil remained wet until the end of the emergence period (23 May).

Emergence, mortality and mycosis of flies

To evaluate the quality of the formulated products, barley grains from both fungus isolates were placed on moist peat: all grains showed fungus outgrowth and heavy sporulation.

Conidia viability was tested by spread-plating the conidia onto water agar plates. *B. bassiana* showed a higher germination rate of conidia ($54.8 \pm 3.6\%$) than *M. anisopliae* ($13.0 \pm 3.6\%$).

Soil treatment had no effect on fly emergence (two-way ANOVA: treatment: $F_{2,14}=0.57$, $p=0.58$; origin of pupae: $F_{1,14}=0.07$, $p=0.80$). The emergence rate was $25.4 \pm 4.7\%$ in the control plots, and $20.0 \pm 7.0\%$ and $31.3 \pm 8.1\%$ in the *B. bassiana* and *M. anisopliae* treated plots, respectively. Fly mortality was affected by soil treatments: *B. bassiana* treatments significantly increased mortality compared to the control and compared to *M. anisopliae* treatments (Figure 21). No significant differences were found between the *M. anisopliae* treatments and the control. When placed on moist peat, $90.6 \pm 8.2\%$ of the dead flies in the *B. bassiana* treatment and $71.0 \pm 15.5\%$ of the dead flies in the *M. anisopliae* treatment showed mycosis. No fungus-infected flies were found in the control. Differences between the control and both fungus treatments were significant (Data transformed $[\arcsin\sqrt{x}]$, two-way ANOVA: treatment: $F_{2,13}=22.64$, $p<0.001$, origin of pupae: $F_{1,13}=5.95$, $p=0.03$). The origin of pupae exposed in the soil had a significant effect on the rate of mycosis. With a mycosis rate of $73.4 \pm 16.1\%$, the flies from Eptingen showed significantly higher mycosis rate than the flies from Sissach ($42.5 \pm 14.4\%$). The number of eggs per female was significantly reduced in the *B. bassiana* treatment (Figure 21). Based on the number of eggs, the efficacy (Abbott's formula) was 88% for *B. bassiana* and 41% for *M. anisopliae*.

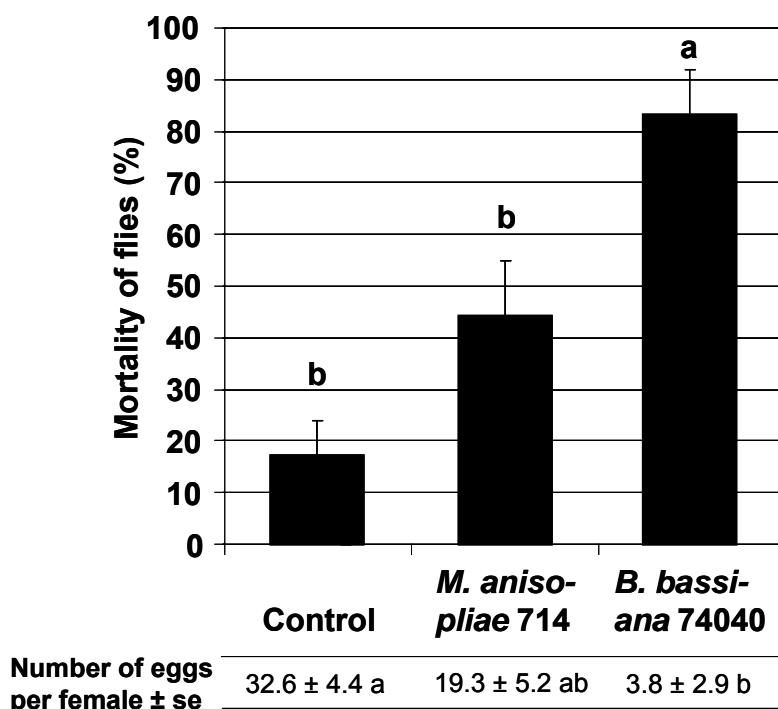

Figure 21: Effects of soil treatments with *B. bassiana* and *M. anisopliae* formulated on barley grains on mortality (\pm se) of emerging adult *R. cerasi* and on number of eggs (\pm se) per female (Statistical analysis for mortality: Data transformed $[\arcsin\sqrt{x}]$, two-way ANOVA; treatment: $F_{2,14}=13.07$, $p<0.001$; origin of fly pupae: $F_{1,14}=0.42$, $p=0.53$; statistical analysis for number of eggs per female: two-way ANOVA: treatment: $F_{2,13}=9.84$, $p=0.003$; origin of pupae: $F_{1,13}=1.12$, $p=0.31$; Tukey HSD-Test $\alpha=0.05$; different letters show significant differences).

C.4. Discussion

The 2007 experiment showed that soil treatments with barley grain formulated entomopathogenic fungi significantly increased mortality of adult *R. cerasi*. Hence,

oviposition rate was reduced by up to 90%. These results are consistent with those of the laboratory experiments (part A) as well as with those of the laboratory experiments of Yee & Lacey (2005), who tested soil treatments against emerging *R. indifferens*. The emergence rate of flies was not reduced by soil treatment. Again, this result is consistent with the laboratory results (part A) and with Yee & Lacey (2005). The low emergence rate observed in all experimental plots (only 25% of exposed pupae) might have been due to the extremely wet soil conditions. Although only lower moisture levels were compared in the laboratory experiments (part A), the observations show a similar trend: a significant reduction of emergence was found in soil with higher moisture content.

B. bassiana was found to be more effective than *M. anisopliae* in the semi-field experiments, whereas conidia suspensions of *M. anisopliae* were more effective than suspensions of *B. bassiana* in the laboratory experiments (part A). Differences between the two fungus isolates observed during the semi-field experiments might be attributable to the different production conditions of the barley grains: *M. anisopliae* was obtained from large scale production of the company Eric Schweizer AG (Thun, Switzerland), whereas *B. bassiana* was produced under small scale conditions in my own laboratory. Both fungus isolates seem worthwhile for further investigations under field conditions.

Besides the laboratory study of Yee & Lacey (2005), there are only a few publications on soil treatments with entomopathogenic fungi for controlling of Tephritid flies. In most cases, soil treatments were focused on L₃ larvae, mainly *C. capitata*, shortly before pupation with varying success (Garcia et al., 1989; Lezama-Gutierrez et al., 2000; Ekesi et al., 2003; Destefano et al., 2005; Ekesi et al., 2005; Mochi et al., 2006). No results are available on soil treatments to control univoltine Tephritid flies and under field conditions in temperate zones. The results of the 2007 experiments provide first evidence that infection of adult Tephritid flies by soil treatments with entomopathogenic fungi is possible under field conditions in temperate zones.

However, weather conditions in 2007 were rather atypical: The soil was very dry in April during the establishment of the fungi and extremely wet during the emergence period of the flies. Although Kessler et al. (2003) state that soil moisture is not a major factor influencing growth and establishment of *B. brongniartii*, waterlogged soils might inhibit the development of entomopathogenic fungi as a result of an oxygen deficiency. A similar observation was made by Lingg & Donaldson (1981), who observed that survival of *B. bassiana* spores decreased as soil moisture content increased. Because fungi and flies seem to be negatively affected by wet soil conditions, further research is needed before drawing general conclusions. In addition, the effect of different soil types should be evaluated, as it is known that soil type and pH level can affect fungus development. Groden (1991) showed that fungistatic levels of soils increased exponentially with increases in soil pH. He tested the effects on *B. bassiana* in soils with pH levels ranging from 5.1 to 7.0. With a pH level of 7.5, the soil in Frick is even more alkaline, which obviously had no marked negative effect on fungus development.

Comparing the rates of mycosis obtained by treatments with conidia suspensions in 2006 and the rates of mycosis observed after the treatment with barley grain formulated fungi, it seems that the barley grain formulation might be more suitable for soil application. Vänninen et al. (2000) showed that most of the conidia were retained in the application layer after soil

treatments with conidia suspensions. Clay particles can adsorb unformulated conidia, resulting in their retention in the surface layer (Vänninen et al., 2000). In contrast, for the application of barley grain formulated *B. brongniartii* at a rate of 40 kg ha⁻¹, Kessler et al. (2003) showed an average increase of 1 to 5x10³ CFU g⁻¹ dry soil three months after application.

In conclusion, the experiments provide first evidence that control of adult *R. cerasi* is possible with soil treatments of barley grain formulated entomopathogenic fungi under field conditions in temperate zones. Soil treatments are considered to be a promising approach lowering the population level of *R. cerasi*, especially in standard tree orchards, in which on-tree application methods are difficult. A further development of this control strategy seems worthwhile for both tested fungus isolates *B. bassiana* and *M. anisopliae*. However, the results of the one year semi-field experiments do not allow general conclusions. Many questions remain to be answered, notably the influence of climatic conditions, soil type and pH-level.

Discussion of methodological problems in the experiments in 2006

In 2006, some methodological problems were encountered in the experiments: The cool and rainy weather during the emergence period in Aesch prevented the flies from reaching the catching containers at the top of the photo-electors. Photo-electors made from fine-mesh netting were chosen for the experiments in order to affect the environmental impact on the soil surface as little as possible. However, flies were also negatively affected by environmental conditions. The numbers of flies in the catching containers still remained low during the subsequent warmer period in mid-June, indicating that flies might have died before or shortly after emergence.

The number of flies captured per yellow sticky trap in the Aesch orchard was ten times lower than in the previous years. Infestation of fruit was close to zero, not only in the Aesch orchard, but also in all other orchards in the vicinity. Apparently, the cold and rainy weather hit the flies in a very delicate stage of development. In the Eptingen orchard, which is located at a higher altitude, emergence started after the cold period. Flight activity and fruit infestation were comparable to the previous years.

In contrast to the experiment in the Aesch orchard, the experiment in Eptingen was conducted under sunny weather conditions with high temperatures. The constant breeze dried the soil. Under these conditions, more flies were caught in the photo-elector catching containers than in Aesch. However, differences between plots were considerable: under two neighbouring trees of the variety Langstieler five and 39 flies, respectively, were caught in the photo-electors. This difference is difficult to explain, as both trees were approximately the same size, yielded cherries the previous year, and care was taken to set up the photo-electors on the south side of each tree under densely foliated branches. Obviously, the distribution of pupae in the soil is very inhomogeneous and difficult to predict.

The mortality of flies caught in the Eptingen orchard was very high, even in the control treatments. This might have been due to several reasons: even though the catching containers were mostly placed in the shadows of tree canopies, contained a water supply, and the flies were removed daily, high temperatures in the catching containers might still have weakened the flies. In addition, the flies were kept in small plastic cages with only

honey for food during the laboratory evaluation. Although flies fed with honey or sugar showed a life span of approximately 30 days in previous laboratory studies, the lack of a protein source might have led to an increased mortality. Mortality in treated as well as in control flies mainly occurred seven to 14 days after emergence. Fecundity of flies could not be assessed in the small cages. Therefore, only a few conclusions can be drawn from this experiment. Not a single infested fly was found in the PreFeRal®WG treatments. This suggests that PreFeRal®WG is rather unsuitable for soil treatments.

To avoid similar problems in 2007, the depots of pupae were exposed in the soil. With this procedure, the number of flies and the particular emergence site were more predictable. Catching containers were used without photo-electors. They were placed directly on the soil surface above the depot of pupae. Therefore, no additional activity was required for the flies to reach the catching containers after they emerged. During the laboratory observation of mortality, the flies were kept in the same cages as used for the laboratory experiments (see part A). In addition, flies were fed with sugar and yeast hydrolysate. This procedure led to reliable results. However, the experiments have to be repeated in different years and in different soil types before drawing final conclusions on the efficacy of soil treatments for controlling *R. cerasi* during emergence.

Part D – Traps and baits: a prerequisite for attract-and-kill strategies

D.1. Introduction

Attract-and-kill pest management strategies are a clever combination of an attracting agent (e.g. pheromone or food bait) and a killing agent (e.g. insecticide or biocontrol agent). Compared to spray applications of insecticides or biocontrol agents, attract-and-kill strategies have several advantages: (1) They are usually more selective, therefore, side effects on non-target organisms are minimized. (2) They avoid residues on harvested crops. Moreover, (3) inside the bait stations, biocontrol agents are sheltered from environmental impacts.

An essential prerequisite for the development of an attract-and-kill strategy is a highly attractive bait. It has been known for a long time that protein hydrolysates and ammonia-releasing substances are attractive to *R. cerasi* (Wiesmann, 1944). These kinds of food baits are currently the only known attractants for *R. cerasi*. Although described by Katsoyannos (1982), the *R. cerasi* pheromone is still not fully identified (Raptopoulos et al., 1995).

In addition to olfactory baits, *R. cerasi* is known to be highly responsive to visual stimuli (Prokopy, 1969). Remund (1971) determined that daylight fluorescent yellow-coloured flat surfaces are most attractive. Prokopy (1971) suggested that large yellow surfaces represent a super-normal foliage-type stimulus eliciting food-seeking behaviour in *R. cerasi* and *R. pomonella*. He also hypothesized that flies react to yellow on the basis of true colour discrimination. This hypothesis was supported by Agee et al. (1982), who showed that adult *R. cerasi* have a major peak of electroretinographically assessed spectral sensitivity at 485 to 500 nm (yellow green region) and a secondary peak at 365 nm (ultraviolet region). Traps with a sharp increase of reflectance in the 500 to 520 nm region were found to be the most attractive for *R. cerasi* (Prokopy & Boller, 1971a; Agee et al., 1982). Based on this knowledge, a 3-dimensional wing-shaped trap was developed (Rebell® amarillo) and is now used throughout Europe for monitoring and controlling cherry fruit fly populations (Remund & Boller, 1978).

In addition to flat yellow surfaces, Prokopy (1971) showed that *Rhagoletis* flies also react to red or dark coloured spheres of approximately the same size as the host fruit. The attraction of fruit flies to spherical objects is believed to represent a response to mating- and oviposition-site type stimuli. Red spheres of 7.5 cm in diameter are used as traps for the apple maggot fly *R. pomonella* (Prokopy, 1968). The optimal spheres size for *R. cerasi* (2.5 cm in diameter), however, is too small to be used as an effective trap (Prokopy, 1969). Observations by Wiesmann (1937b) indicate that flies detect the location of host fruit solely through vision. Dark coloured spheres are preferred because they stand out in strongest contrast against the background (Levinson & Haisch, 1983). While fruit-mimicking spherical traps are superior for attracting *R. pomonella*, yellow panels were found to be more suitable for capturing *R. cerasi* (Prokopy, 1969; Economopoulos, 1989).

Based on findings cited in the literature, improving the attractiveness of yellow panels by adding a food bait seemed to be the most promising approach. Odour baits might increase the distance of attraction and thus enable the reduction of the required trap density.

In order to evaluate the efficacy of baits independently from field seasons, olfactometer experiments were conducted in the laboratory. Based on the assumption that food baits should mainly attract females during the pre-oviposition period, the reaction of young virgin females (zero to seven days old) was tested in different types of olfactometers. Fed and food-deprived females were used. In a four-chamber olfactometer similar to the one described by Steidle & Schöller (1997), but bigger in size (diameter 24 cm, height 16 cm), the flies were exposed to ammonium acetate (7.7 g per 100 ml) and Frutect® bait (undiluted and diluted 1:40). Absolutely no reaction was observed. Flies mainly remained on the top of the olfactometer and showed no explicit searching behaviour. Changing light intensity or adding a fan to provide airflow did not improve results. Other types of olfactometers were tested without any results. The only olfactometer described for *R. cerasi* in the literature was developed at the Federal Research Station Wädenswil, Switzerland (Katsoyannos et al., 1980). The original olfactometer (type B) was obtained from Dr. Ernst Boller (Federal Research Station Wädenswil, Switzerland) and used for experiments. However, within three hours only 20% of the food-deprived females reacted to Frutect® bait. Because reactions to food baits were very low, males were used to attract virgin, seven to 10 day old females. The results reported by Katsoyannos et al. (1980) and by Katsoyannos (1982), however, could not be reproduced. Experiments with olfactometers were finally abandoned and all baits were tested in field trials.

In preliminary field trials, different commercial trap types were compared: The Rebell® amarillo (Andermatt Biocontrol AG, Grossdietwil, Switzerland), the Frutect® trap with bait and without bait (RonPal Ltd., Rishpon, Israel) and the Celaflor® trap (Celafor® Naturen® Kirschfruchtfliegenfalle with bait; Scotts Celaflor GmbH & Co. KG, Mainz, Germany). Within the experimental period (19 May to 08 July 2003; Aesch orchard, four replicates), Frutect® traps with bait captured higher numbers of flies (373.3 ± 83.2 flies per trap) than the other trap types (Celaflor®: 141.5 ± 46.3 ; Rebell®: 161.3 ± 16.1 flies per trap). However, the Frutect® traps without bait clearly captured the lowest number of flies (88.6 ± 7.1 flies per trap).

Based on these preliminary results, additional experiments were planned. Because the Rebell® traps without bait were more attractive than the Frutect® traps without bait, Rebell® traps were chosen as the standard trap for additional experiments. The wing-shaped, 3-dimensional design of the Rebell® trap with its fluorescent yellow colour (Remund & Boller, 1978) seems better adapted to capture *R. cerasi* than the Frutect® trap. Although they were the least effective without bait, Frutect® traps were highly attractive when baited. The bait seems to have a major impact on numbers of flies captured per trap. The Frutect® bait was therefore chosen as the standard bait for further experiments.

The aim of the experiments was to find a bait suitable for use in an attract-and-kill-strategy in combination with entomopathogenic fungi, or for mass trapping purposes in extensive cherry production and private gardens.

D.2. Materials & methods

D.2.1. Experimental orchards and experimental design

The main experiments in 2004, 2005 and 2006 were conducted in the Aesch orchard. The location of the orchard is given in Annex I. The orchard consisted of 76 cherry trees, of which nine trees of the variety Star, nine trees of the variety Langstieler and nine trees of the

variety Schauenburger were included in the experiment. The trees, planted in 1980, were seven to 10 metres tall and yielded 15 to 20 kg cherries each. Cherries in this orchard had not been harvested in over five years, which led to a high infestation pressure.

In order to permit easy checking, traps were hung at 1.8 to 2.0 m above the ground on the lower branches, 50 cm from the periphery of the trees inside the canopy. Leaves and small branches were pruned around the traps for better exposure to the sun (Russ et al., 1973). Eleven different combinations of traps and baits were compared each year (Table 4). Two traps were placed in each tree on the south and on the southeast side with a distance of 3 to 5 m between traps. Five replicates of each trap/bait combination were arranged in a randomized block design. Details on experimental design are given in Annex II – Figure 6, 7, 8. At the beginning of May in 2004 and 2005, some Rebell® traps were placed in the orchard in order to detect the beginning of the flight period. The experiments were started within two days after the first capture of flies. This procedure was chosen because the beginning of the flight period was difficult to predict and because contamination of the traps prior to the beginning of the experiment needed to be avoided. In 2004, the experiment was started on 21 May and traps were renewed on 15 June. Traps were removed on 20 July 2004. In 2005, the experiment was started on 19 May and traps were removed on 15 July. As more precise knowledge regarding the beginning of the flight period in the Aesch orchard was obtained, the experiment in 2006 was started on 19 May, three days before the first flies were captured. Traps were removed on 04 July.

In 2005, three additional experiments were conducted in the Frick, Möhlin 1 and Sissach 5 orchards. Orchard locations are given in Annex I. The Frick orchard consisted of 14 cherry trees of the variety Langstieler. The trees were approximately seven metres tall and yielded 10 to 15 kg cherries each. In the Möhlin 1 orchard, trees of the variety Kordia were chosen for the experiment. The trees were approximately five metres tall and yielded 5 to 10 kg cherries each. In the Sissach 5 orchard, trees of the variety Kordia were chosen for the experiment. The trees were approximately 10 metres tall and yielded 20 kg cherries each. The same four trap/bait combinations were compared in each orchard (Table 4). A similar experimental design as in the Aesch orchard was chosen: two traps per tree on the south and the southeast side, arranged in a randomized block design with four replicates in each orchard. Details on experimental design are given in Annex II – Figure 9. The experiments were started shortly before the beginning of the flight period on 19 May (Frick orchard), on 23 May (Sissach 5 orchard) and on 27 May 2005 (Möhlin 1 orchard). All traps were removed on 13 July 2005.

In 2006, one additional experiment was conducted in the Eptingen orchard. The location of orchard is given in Annex I. Trees of the varieties Dolleseppeler and Langstieler were chosen for the experiment. The 30-year old trees were approximately four to five metres tall and yielded 15 to 25 kg cherries each. Eight trap/bait combinations were compared (Table 4). A similar experimental design as in Aesch was chosen: two traps per tree on the south and the southeast side, arranged in a randomized block design with four replicates. Details on experimental design are given in Annex II – Figure 10. The experiment was started one week after the beginning of the flight period on 16 June 2006 and the traps were removed on 14 July 2006.

D.2.2. Traps and baits

Based on the preliminary experiments, Rebell® amarillo traps (Andermatt Biocontrol AG, Grossdietwil, Switzerland) were chosen as the standard trap in combination with different baits. Fructect® traps (RonPal Ltd., Rishpon, Israel) baited with Fructect® bait or water were included in all experiments.

The Fructect® trap consists of one 29 cm x 29 cm yellow plastic panel (total sticky surface 1545 cm²) with an 11 cm diameter red sphere in the centre. The sphere is filled with a liquid bait. The Rebell® trap consists of two 20.5 cm x 15 cm yellow plastic panels fastened together at right angles (total sticky surface 1230 cm²). In combination with Rebell® traps, all baits were placed in 0.5 l plastic bottles. These bottles were hung under the Rebell® traps. In 2004, the effect of bait placement was evaluated using two types of bottles: bottles used for *Xyleborus dispar* F. (Coleoptera: Scolytidae) and plastic bottles cut open and nested closely under the trap. In 2005 and 2006, the bottles were just hung under the trap. To avoid the influence of bait colour on captures and to shelter the bait from direct sunlight, the bottom parts of the bottles were coloured dark green. Table 4 lists all details on traps and baits used in the experiments in the Aesch orchard in 2004, 2005, and 2006. In addition, details on traps and baits used in the Frick, Möhlin 1, and Sissach 5 orchards in 2005 as well as in the experiment in Eptingen in 2006 are given in Table 4.

D.2.3. Evaluations

In the Aesch and Eptingen orchards, the number of female and male flies per trap was counted twice a week. In the Frick, Möhlin 1, and Sissach 5 orchards, the number of female and male flies per trap was counted once a week. Bait bottles were refilled as necessary after rain or desiccation. To summarize the results, two time periods were considered: (1) The number of flies per trap over the experimental period (total captures). (2) The number of flies caught until two weeks prior to harvest (early captures). The latter period was chosen because it is desirable to catch the flies during the pre-oviposition period in order to avoid fruit damage. For both periods, the number of flies per week was calculated to adjust for the different lengths of flight periods in different experimental years.

In order to evaluate the side effects of the traps on non-target arthropods, all insects were counted and removed from the traps on 14 June 2005 (Frick orchard, 26 days after installation of traps) and on 22 June 2006 (Möhlin 1 and Sissach 5 orchards; 26 and 30 days after installation of the traps, respectively). Non-target arthropods and debris were removed from the trap surface after each counting.

Fly emergence was monitored in order to compare the period of emergence with the period of flight activity. In the Aesch orchard 2004, fly emergence under trees of the variety Langstieler was monitored using photo-electors made from cement (40 electors; area 0.22 m², Figure 22). The photo-electors were installed on 11 May 2004 and checked twice a week until 09 July 2004. In the Eptingen orchard in 2006, emergence was monitored using photo-electors made from fine-mesh netting (24 electors in each orchard; area 2 m², Figure 22). Photo-electors were installed on 08 June 2006, checked daily, and removed on 23 June 2006.

Table 4: Traps and baits used in the experiments. (x* "Agar"-bait not in bottle, but shrink-wrapped in plastic).

Abbreviation (Trap / bait)	Trap type	Bait	Aesch orchard			Frick, Möhlin 1, Sissach 5	Eptin- gen
			2004	2005	2006		
Rebell / Water	Rebell® with bottle	Water	x	x	x	x	x
Rebell / Fructect	Rebell® with bottle	Fructect® bait for <i>R. cerasi</i> (protein hydrolysate; RonPal Ltd., Rishpon, Israel)	x	x	x		x
Rebell X/ Fructect	Rebell® with bottle for <i>X. dispar</i>	Fructect® bait for <i>R. cerasi</i> (protein hydrolysate; RonPal Ltd., Rishpon, Israel)	x				
Fructect / Water	Fructect® trap	Water	x	x	x		x
Fructect / Fructect	Fructect® trap	Fructect® bait for <i>R. cerasi</i> (protein hydrolysate; RonPal Ltd., Rishpon, Israel)	x	x	x		x
Rebell / Fructect olive	Rebell® with bottle	Fructect® bait for <i>B. oleae</i> (protein hydrolysate; RonPal Ltd., Rishpon, Israel)	x				
Rebell / 5%+50%	Rebell® with bottle	New composition: phosphate buffer solution pH 6.3 (Fluka, Buchs, Switzerland) with 5% yeast hydrolysate (No.12011, Sonaris AG, Rheinfelden, Switzerland), 50% ammonium acetate (purity≥ 97.0%; Fluka, Buchs, Switzerland)	x	x	x		
Rebell / 2.5%+10%	Rebell® with bottle	New composition: phosphate buffer solution pH 6.3 with 2.5% yeast hydrolysate, 10% ammonium acetate, 0.1% Oxykuper®50 (50% copper oxychloride, Stähler Suisse SA, Zofingen, Switzerland; to minimize microbial decomposition)	x				
Rebell / Lysodin	Rebell® with bottle	Lysodin Algafert (liquid organic fertilizer produced from hydrolyzed hides; Intrachem Bio Italia S.P.A.)	x		x		x
Rebell / Nu Lure	Rebell® with bottle	Nu Lure (protein hydrolysate, Intrachem Bio Italia S.p.A.)	x				
Rebell / Agar	Rebell® with bottle	New composition: 9.5% ammonium acetate (purity≥ 97.0%; Fluka, Buchs, Switzerland), 21% Trimethylamine solution (purity ~45% in water, Fluka, Buchs, Switzerland), 1% 1,4-Diaminobutane (purity≥ 98.0%; Fluka, Buchs, Switzerland) formulated in Agar (15 g l ⁻¹ ; Agar bacteriological, Agar No. 1; LP0011, Oxoid Ltd., Basingstoke, UK)	x	x*	x		x*

Table 4: continued

Abbreviation (Trap / bait)	Trap type	Bait	Aesch orchard			Frick, Möhlin 1, Sissach 5	Eptin- gen
			2004	2005	2006		
Rebell / Agar+Pep	Rebell® with bottle	New composition: as above with additional 10% of proteose peptone (LP0085, Oxoid Ltd., Basingstoke, UK)		x*			
Rebell / Agar AA	Rebell® with bottle	9.5% ammonium acetate formulated in Agar (15 g l ⁻¹)		x*			
Rebell / Agar DAB	Rebell® with bottle	1% 1,4-Diaminobutane formulated in Agar (15 g l ⁻¹)		x*			
Rebell / Agar TMA	Rebell® with bottle	21% Trimethylamine solution formulated in Agar (15 g l ⁻¹)		x*			
Rebell / Biobest	Rebell® with bottle	Biobest lure for <i>R. cerasi</i> (Biobest N.V., Westerlo, Belgium)		x			
Rebell / Süsbin TMD	Rebell® with bottle	Trimedlure plugs for control of <i>C. capitata</i> (Süsbin, Division agro de Quemar S.R.L., Argentina)			x		
Rebell / Süsbin TMA	Rebell® with bottle	TMA-card containing Trimethylamine and other amines (Süsbin, Division agro de Quemar S.R.L., Argentina)			x		x
Rebell / Süsbin	Rebell®	Newly developed, not yet commercially available tablet with <i>R. cerasi</i> pheromone (Süsbin, Division agro de Quemar S.R.L.)			x		x
Rebell / Stable	Rebell® with bottle	Bait for stable flies (Rescue!® Fly trap; Sterling International Inc., Spokane, WA, USA)			x		
Rebell / Urevit	Rebell® with bottle	Urevit: urine processed by electro dialysis and subsequent ozonation as described by Pronk et al. (2007)					x



Figure 22: Photo-electric traps used to monitor fly emergence in Aesch 2004 (left) and in Eptingen 2006 (right).

D.2.4. Statistical analysis

The number of flies per trap and per week was calculated in order to adjust the different lengths of experimental periods in the different years to comparable values. These data were $[\log_{10}(x+1)]$ transformed before analysis. The proportion of females per trap was $[\arcsin\sqrt{x}]$ transformed. Normality of data and homogeneity of variance were tested. A linear model (ANOVA) was conducted using JMP version 5.0.1.2.. The most parsimonious model was chosen by stepwise elimination of non-significant factors.

The efficacy of the Rebell® and Frutect® traps with and without bait was compared based on pooled data from the three experimental years in the Aesch orchard. Means were compared using Tukey HSD post hoc tests ($\alpha=0.05$). Student's t-test ($\alpha=0.05$) was used to compare the efficacy of different baits with the standard trap (Rebell® baited with water). The proportion of females per trap was $[\arcsin\sqrt{x}]$ transformed. Because the total number of flies varied considerably between years and is not taken into account by analysing transformed percentage rates, a second analysis was conducted: a multiple logistic regression was calculated with the statistical software R (R Development Core Team, 2006), using the absolute numbers of female and male flies. Significance was assessed by the change in deviance (Chi-Square). The assumed error structures (binomial) were checked to avoid over-dispersion.

For small count data obtained from the evaluation of non-target insects, Poisson distributed error variances were assumed. A log-linear model was calculated using statistical software R. Significance was assessed by the change in deviance (Chi-Square). The assumed error

structures were checked to avoid over-dispersion. For large count data (<90), normal distributed error variances were assumed. These data were $[\log_{10}(x+1)]$ transformed, tested for normality and homogeneity of variance, and analysed by a linear model (ANOVA) using JMP version 5.0.1.2..

Unless mentioned otherwise, the results presented in the text and the tables are means with standard errors and letters indicating significant differences.

D.3. Results

D.3.1. Comparison of standard traps over three years

Aesch orchard 2004, 2005, 2006: Climatic conditions and flight period of *R. cerasi*

In order to compare the efficacy of Rebell® and Fructect® traps (with and without Fructect® bait), the data from the three experimental years in the Aesch orchard were pooled. Climatic conditions during the experimental periods are given in Annex III – Figures 1, 2, and 3. Peak flight activity was observed between 6 and 11 June 2004, and between 17 and 24 June 2005. In 2006, two peaks occurred: the first between 9 and 16 June and the second between 27 and 30 June.

Aesch orchard 2004, 2005, 2006: Total captures of *R. cerasi*

The factors trap and year were found to have a significant effect on the average number of flies per week captured over the whole experimental period (data transformed $[\log_{10}(x+1)]$; three-way ANOVA: trap/bait: $F_{3,52}=13.41$, $p<0.001$; variety: $F_{2,52}=3.09$, $p=0.05$; year: $F_{2,52}=76.33$, $p<0.001$; Tukey HSD test $\alpha=0.05$). With bait, both trap types captured significantly more flies than without bait: Baited Rebell® traps captured 23.84 ± 3.82 [a] flies per week and baited Fructect® traps captured 19.23 ± 3.37 [ab] flies per week. Unbaited Rebell® traps captured 14.73 ± 2.96 [b] flies per week, unbaited Fructect® traps captured 8.26 ± 1.49 [c] flies per week. No significant differences were found between baited Fructect® traps and unbaited Rebell® traps.

The flight activity in 2006 was significantly lower than in the two previous years (2004: 22.24 ± 2.56 ; 2005: 22.42 ± 2.57 ; 2006: 4.88 ± 1.33 flies per trap and week). Traps in the variety Star tended to capture fewer flies than traps in the variety Schauenburger.

Aesch orchard 2004, 2005, 2006: Early captures of *R. cerasi*

Similar effects were found in the early captures (data transformed $[\log_{10}(x+1)]$; three-way ANOVA: trap/bait: $F_{3,52}=7.65$, $p<0.001$; variety: $F_{2,52}=5.71$, $p=0.006$; year: $F_{2,52}=75.75$, $p<0.001$; Tukey HSD test $\alpha=0.05$). Baited Rebell® traps captured 25.12 ± 7.01 [a] flies per week and baited Fructect® traps captured 25.38 ± 7.26 [a] flies per week. On unbaited Rebell® traps, 12.82 ± 2.95 [ab] flies per week were captured. Unbaited Fructect® traps captured 7.07 ± 1.73 [b] flies per week.

Flight activity in 2004 (34.43 ± 5.75 [a] flies per week) was significantly higher than in 2005 (15.75 ± 4.25 [b] flies per week) and in 2006 (2.60 ± 0.56 [c] flies per week). Significantly more flies were captured on traps hanging in the variety Star and Langstieler than on traps hanging in variety Schauenburger.

Aesch orchard 2004, 2005, 2006: Proportion of females

The proportion of female flies was significantly affected by trap/bait combination, trap location, and year (early captures; data transformed [$\arcsin\sqrt{(x/100)}$]; three-way ANOVA: trap/bait: $F_{3,43}=5.02$, $p=0.005$; location [south vs. southeast side of tree]: $F_{1,43}=18.74$, $p<0.001$; year: $F_{2,43}=5.08$, $p=0.01$; location*year: $F_{2,43}=4.56$, $p=0.02$; trap/bait*year: $F_{6,43}=2.73$, $p=0.02$; Tukey HSD test $\alpha=0.05$). Unbaited Frutect® traps captured a significantly higher proportion of females ($62.28\pm 4.56\%$ [a] females) than unbaited Rebell® traps ($49.88\pm 2.50\%$ [b] females). On baited Frutect® and Rebell® traps, $58.36\pm 3.00\%$ [ab] and $56.63\pm 3.96\%$ [ab] females were captured. A significantly higher proportion of females was captured on traps on the southeast side of the tree ($62.21\pm 3.35\%$ females) than on traps on the south side of the trees ($52.76\pm 1.83\%$ females). In 2005, a significantly higher proportion of females was observed ($62.14\pm 2.62\%$ [a] females) than in 2004 ($53.11\pm 1.46\%$ [a] females; 2006: $54.54\pm 4.73\%$ [ab] females).

A second statistical analysis of these data gave similar results: sex ratio was significantly affected by trap/bait combination and trap location (Logistic regression: early captures; trap location [south vs. southeast side of tree]: Deviance=3.83, $df=1$, $p=0.05$; trap/bait: Deviance=12.66, $df=3$, $p=0.005$; year: Deviance=1.50, $df=2$, $p=0.47$; location*year: Deviance=14.48, $df=2$, $p=0.001$; trap/bait*year: Deviance=23.42, $df=6$, $p=0.001$). The sex ratio of the total captures was not affected by any of the measured factors.

D.3.2. Comparison of different baits

Aesch orchard 2004: Climatic conditions and *R. cerasi* emergence

Climatic conditions during the experimental period are given in Annex III – Figure 1. A total of 12145 flies were captured on the 55 traps over the whole experimental period in 2004.

Fly emergence was monitored using photo-electors. Peak emergence was observed between 1 and 11 June 2004 (Figure 23). Peak flight activity was observed during the warm and sunny days from 6 to 11 June 2004 (Figure 23). Although emergence was completed by mid-June, there was considerable flight activity until mid-July. More female (60.5%) than male flies were observed in the photo-electors. On the traps, however, fewer females (48.3%) than males were captured.

As shown in Table 5 more flies per week were captured in the beginning of the flight period (early captures) than over the whole flight period (total captures). In addition, the proportion of captured females was higher in the beginning of the flight period (average over all trap/bait combinations: 53.7% females) than over the whole flight period (48.3% females).

Aesch orchard 2004: Early captures of *R. cerasi*

The trap/bait combination had a significant effect on the number of flies captured until two weeks before harvest (data transformed [$\log_{10}(x+1)$]; three-way ANOVA: trap/bait: $F_{10,37}=4.83$, $p<0.001$; yield: $F_{3,37}=3.87$, $p=0.02$; block: $F_{4,37}=2.87$, $p=0.04$; Student's t-test $\alpha=0.05$; Table 5). Compared to the standard Rebell® trap baited with water, the following baits significantly increased the number of captured flies: bait made from 5% yeast hydrolysate and 50% ammonium acetate, "Agar"-bait, Frutect® bait, and bait made from

2.5% yeast hydrolysate and 10% ammonium acetate. No bait resulted in significantly greater captures than the standard bait (Fructect®). Nevertheless, compared to the Fructect® bait, the “Agar”-bait increased number of flies captured by 38%, and the bait made from 5% yeast hydrolysate and 50% ammonium acetate increased the number of flies captured by 50%. In 2004, the yield varied among the trees and was classified as 0 = no yield, 1 = very little yield, 2 = little yield, and 3 = normal yield. The class of yield had a significant effect on the number of flies captured (early captures): fly captures were lower in trees without yield (class 0) than in trees with little to normal yield (classes 1 to 3).

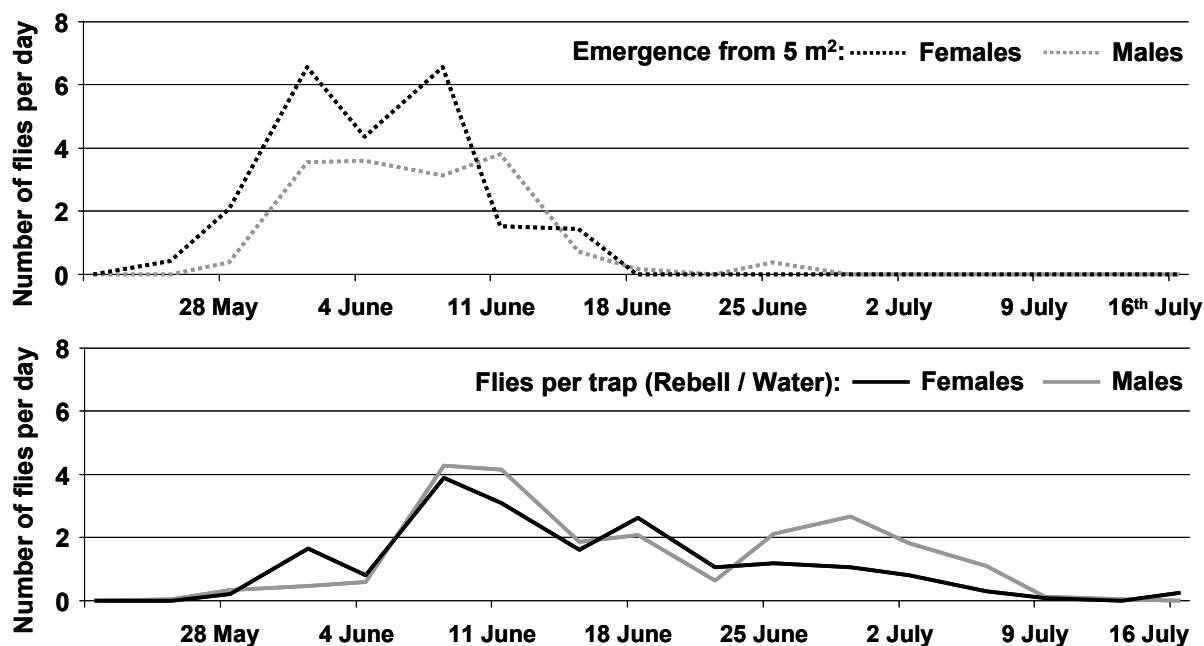

Figure 23: Fly emergence per 5 m² monitored with photo-electors and flight period monitored with Rebell® traps in the Aesch orchard in 2004.

Aesch orchard 2004: Total captures of *R. cerasi*

Similar effects were observed in terms of the number of flies captured per week over the whole experimental period. Differences, however, were less pronounced (data transformed [$\log_{10}(x+1)$]; three-way ANOVA: trap/bait: $F_{10,37}=3.10$, $p=0.006$; yield: $F_{3,37}=2.64$, $p=0.06$; block: $F_{4,37}=4.87$, $p=0.003$; Student's t-test $\alpha=0.05$; Table 5). Compared to the standard Rebell® trap with water, the following baits significantly increased the number of captured flies: “Agar”-bait, bait made from 5% yeast hydrolysate and 50% ammonium acetate, Fructect® bait, and bait made from 2.5% yeast hydrolysate and 10% ammonium acetate. No bait resulted in significantly greater captures than the standard bait (Fructect®). Nevertheless, compared to the Fructect® bait, the “Agar”-bait increased the number of flies captured by 21%, and the bait made from 2.5% yeast hydrolysate and 10% ammonium acetate increased the number of flies captured by 15%.

Aesch orchard 2004: Proportion of females

The proportion of female flies was significantly affected by trap/bait combination and cherry variety (early captures; data transformed [$\arcsin\sqrt{(x/100)}$]; three-way ANOVA: trap/bait: $F_{10,38}=3.65$, $p=0.002$; variety: $F_{2,38}=4.33$, $p=0.02$; block: $F_{4,38}=3.14$, $p=0.03$; Student's t-test

$\alpha=0.05$; Table 5). Compared to the standard Rebell® trap baited with water, the following baits significantly increased the proportion of female flies: bait made from 5% yeast hydrolysate and 50% ammonium acetate, and Fructect® bait for olive flies. A significantly higher proportion of females was captured in the variety Star than in the variety Langstieler.

Over the whole flight period, the factors trap/bait combination, cherry variety, and trap location had a significant effect on the proportion of females (total captures; data transformed [$\arcsin\sqrt{(x/100)}$]; four-way ANOVA: trap/bait: $F_{10,37}=4.77$, $p<0.001$; variety: $F_{2,37}=7.98$, $p=0.001$; location [south vs. southeast side of tree]: $F_{1,37}=12.93$ $p<0.001$; block: $F_{4,37}=2.60$, $p=0.05$; Student's t-test $\alpha=0.05$; Table 5). Compared to the standard Rebell® trap baited with water, the following baits significantly increased the proportion of female flies: "Agar"-bait, and bait made from 5% yeast hydrolysate and 50% ammonium acetate. A significantly higher proportion of females was captured in the variety Langstieler than in the variety Schauenburger. The location of the traps in the tree canopy significantly affected the proportion of captured females: traps in the southeast side of the canopy captured a higher proportion of females than traps in the south side of the canopy.

Table 5: Results of experiments in the Aesch orchard in 2004.

Aesch orchard, 2004	Early captures (21 May to 11 June, 21 days)		Total captures (21 May to 20 July, 60 days)	
	Flies per week	% females	Flies per week	% females
Rebell/Water	22.87±4.92 [cd]	51.27±2.25	17.20±4.32 [cd]	47.18±1.90
Rebell/Fructect	44.00±14.21 [ab]	56.23±3.11	29.05±5.16 [ab]	45.22±3.94
RebellX/Fructect	42.00±12.57 [a]	53.39±2.30	29.31±5.97 [ab]	46.11±3.51
Fructect/Water	14.87±2.21 [d]	47.26±2.70	13.23±1.85 [d]	43.75±2.37
Fructect/Fructect	56.00±11.35 [a]	57.67±1.19	29.47±4.95 [ab]	55.02±1.84
Rebell/Fructect-olive	37.67±5.07 [abc]	57.70±1.03	25.97±5.03 [abc]	50.52±2.33
Rebell/5%+50%	66.07±23.05 [a]	58.75±1.84	33.44±9.42 [a]	55.22±2.58
Rebell/2.5%+10%	43.47±11.09 [ab]	53.99±2.02	26.16±3.64 [ab]	48.56±1.07
Rebell/Lysodin	40.87±12.03 [abc]	47.82±3.00	24.55±4.83 [abc]	42.95±2.07
Rebell/Nu Lure	24.47±6.27 [bcd]	49.41±4.02	19.90±5.58 [bcd]	44.28±2.95
Rebell/Agar	60.80±9.38 [a]	57.26±3.89	35.12±4.25 [a]	52.20±4.01

Aesch orchard 2005: Climatic conditions and flight period of *R. cerasi*

Climatic conditions during the experimental period are given in Annex III – Figure 2. In 2005, a total of 9566 flies was captured on the 55 traps over the whole experimental period. Peak flight activity was observed between 17 and 24 June 2005. As shown in Table 6, fewer flies per week were captured in the beginning of the flight period (early captures) than over the whole flight period (total captures). The proportion of captured females was higher in the beginning of the flight period (average over all trap/bait combinations: 59.6% females) than over the whole flight period (48.4% females). In 2005, the yield was homogenous from all trees. The yield in the previous year (2004) did not affect the number of flies captured per trap.

Aesch orchard 2005: Early captures of *R. cerasi*

The trap/bait combination had a significant effect on the number of flies captured until two weeks prior to harvest (data transformed $[\log_{10}(x+1)]$; three-way ANOVA: trap/bait: $F_{10,39}=3.80$, $p=0.001$; trap location [south vs. southeast side of tree]: $F_{1,39}=4.55$, $p=0.04$; block: $F_{4,39}=15.26$, $p<0.001$; Student's t-test $\alpha=0.05$; Table 6). In the Rebell® traps, however, no bait resulted in significantly greater captures than the water-bait. Tested separately, the components of the "Agar"-bait (Ammonium acetate, Diaminobutane, Trimethylamine) were significantly less effective than in combination. Trap location within the trees significantly affected the number of flies captured: Traps on the on the south side captured an average of 15.57 ± 3.08 flies per week. Traps on the southeast side captured an average of 9.60 ± 1.49 flies per week.

Aesch orchard 2005: Total captures of *R. cerasi*

Similar results were obtained in terms of the number of flies caught per week over the whole experimental period. In the Rebell® traps, no bait resulted in significantly greater captures than the water-bait (data transformed $[\log_{10}(x+1)]$; three-way ANOVA: trap/bait: $F_{10,39}=6.36$, $p<0.001$; trap location [south vs. southeast side of tree]: $F_{1,39}=0.80$, $p=0.38$; block: $F_{4,39}=12.10$, $p<0.001$; Student's t-test $\alpha=0.05$; Table 6). Tested separately, the components of the "Agar"-bait (Ammonium acetate, Diaminobutane, Trimethylamine) were significantly less effective than in combination.

Aesch orchard 2005: Proportion of females

The baits had no effect on the proportion of female flies (early captures; data transformed $[\arcsin\sqrt{(x/100)}]$; two-way ANOVA: trap/bait: $F_{10,43}=1.27$, $p=0.28$; location [south vs. southeast side of tree]: $F_{1,43}=6.07$, $p=0.02$; Student's t-test $\alpha=0.05$; Table 6). Compared to the Rebell® trap baited with water, only the Frutect® trap baited with water tended to increase the proportion of female flies captured. The trap location in the tree canopy had a significant effect on the proportion of females captured: traps in the southeast side of the canopy captured a higher proportion of females than traps in the south side of the canopy.

Over the whole experimental period, the proportion of female flies was not affected by trap/bait combination (total captures; data transformed $[\arcsin\sqrt{(x/100)}]$; three-way ANOVA: trap/bait: $F_{10,41}=1.86$, $p=0.08$; location [south vs. southeast side of tree]: $F_{1,41}=6.82$, $p=0.01$; variety: $F_{2,41}=16.24$, $p<0.001$; Student's t-test $\alpha=0.05$; Table 6). A significantly higher proportion of females was captured in the variety Star than in the varieties Langstieler or Schauenburger. Trap location in the tree canopy had a significant effect on the proportion of captured females: traps in the southeast side of the canopy captured a higher proportion of females than traps in the south side of the tree canopy.

Table 6: Results of experiments in the Aesch orchard in 2005.

Aesch orchard, 2005	Early captures (19 May to 10 June, 22 days)		Total captures (19 May to 15 July, 57 days)	
	Flies per week	% females	Flies per week	% females
Rebell/Water	12.79±4.10 [ab]	54.75±2.48	22.62±5.21 [ab]	41.70±4.69
Rebell/Frutect	26.60±15.01 [a]	58.45±5.45	32.57±5.72 [a]	44.77±3.48
Frutect/Water	5.22±1.17 [c]	70.46±4.57	10.14±0.96 [c]	54.16±4.56
Frutect/Frutect	18.39±6.17 [a]	64.89±6.10	24.34±0.80 [a]	49.43±2.65
Rebell/5%+50%	18.45±3.79 [a]	62.75±2.35	25.64±4.87 [a]	54.34±1.93
Rebell/Agar	13.81±5.48 [a]	59.61±4.76	25.89±4.67 [a]	46.15±4.50
Rebell/Agar+Pep	11.84±3.21 [ab]	52.78±4.94	25.52±6.81 [a]	43.04±4.65
Rebell/Agar AA	7.51±2.47 [bc]	57.41±8.95	15.42±4.04 [bc]	49.26±6.79
Rebell/Agar DAB	7.51±1.72 [bc]	55.19±6.42	11.64±2.30 [c]	48.52±4.44
Rebell/Agar TMA	5.92±1.66 [bc]	60.20±5.95	15.72±3.05 [bc]	50.99±1.51
Rebell / Biobest	11.01±3.02 [ab]	58.60±3.01	25.45±5.34 [a]	49.87±4.59

Aesch orchard 2006: Climatic conditions and flight period of *R. cerasi*

Climatic conditions during the experimental period are given in Annex III – Figure 3. In 2006, flight activity was considerably lower compared to the prior years. A total of 2170 flies was captured on the 55 traps over the whole experimental period. Two peaks of flight activity were observed: the first between 9 and 16 June and the second between 27 and 30 June.

As shown in Table 7, fewer flies per week were captured in the beginning of the flight period (early captures) than over the whole flight period (total captures). The proportion of captured females was higher in the beginning of the flight period (average over all trap/bait combinations: 52.65% females) than over the whole flight period (43.42% females).

Aesch orchard 2006: Early captures of *R. cerasi*

The trap/bait combination had a significant effect on the number of flies caught until two weeks prior to harvest (data transformed [$\log_{10}(x+1)$]; three-way ANOVA: trap/bait: $F_{10,38}=4.73$, $p<0.001$; variety: $F_{2,38}=3.21$, $p=0.05$; block: $F_{4,38}=10.95$, $p<0.001$; Student's t-test $\alpha=0.05$; Table 7). Compared to the standard Rebell® trap baited with water, only the TMA-card resulted in a significantly greater number of flies captured. No bait resulted in significantly greater catches than the standard bait (Frutect®). Nevertheless, compared to the Frutect® bait, the TMA resulted in a 140% increase in the number of flies caught, and the bait made from 5% yeast hydrolysate and 50% ammonium acetate resulted in a 47% increase in the number of flies captured.

Aesch orchard 2006: Total captures of *R. cerasi*

Similar results were obtained in terms of the number of flies per week captured over the whole experimental period (data transformed [$\log_{10}(x+1)$]; three-way ANOVA: trap/bait: $F_{10,38}=4.64$, $p<0.001$; variety: $F_{2,38}=1.70$, $p=0.20$; block: $F_{4,38}=18.44$, $p<0.001$; Student's t-test

$\alpha=0.05$; Table 7). Compared to the standard Rebell® trap baited with water, only the TMA-card and the bait made from 5% yeast hydrolysate and 50% ammonium acetate significantly increased the number of flies captured. No bait resulted in significantly greater catches than the standard bait (Frutect®). Nevertheless, compared to the Frutect® bait, the TMA card resulted in a 12% increase in the number of flies captured, and the bait made from 5% yeast hydrolysate and 50% ammonium acetate resulted in a 37% increase in the number of flies captured.

Aesch orchard 2006: Proportion of females

No measured factor had any effect on the proportion of female flies caught in the beginning of the flight period (early captures; data transformed [$\arcsin\sqrt{(x/100)}$]; three-way ANOVA: trap/bait: $F_{10,39}=1.72$, $p=0.11$; variety: $F_{2,39}=1.68$, $p=0.20$; trap location [south vs. southeast side of tree]: $F_{1,39}=0.64$, $p=0.43$; Table 7). Over the whole experimental period, trap location had a significant effect on the proportion of females captured: Traps in the southeast side of the canopy captured a higher proportion of females than traps in the south side of the canopy. Trap/bait combination had no effect (total captures; data transformed: [$\arcsin\sqrt{(x/100)}$]; two-way ANOVA: trap/bait: $F_{10,42}=0.57$, $p=0.83$; trap location [south vs. southeast side of tree]: $F_{1,42}=10.26$, $p=0.003$; Table 7).

Table 7: Results of experiments in the Aesch orchard in 2006.

Aesch orchard, 2006	Early captures (19 May to 13 June, 25 days)		Total captures (19 May to 04 July, 46 days)	
	Flies per week	% females	Flies per week	% females
Rebell/Water	2.80±0.50 [bc]	43.64±6.17	18.80±6.45 [cd]	43.10±5.45
Rebell/Frutect	4.76±1.75 [bc]	55.22±11.15	46.18±23.65 [abc]	41.99±6.53
Frutect/Water	1.12±0.59 [e]	70.83±11.02	5.64±1.24 [e]	50.27±8.47
Frutect/Frutect	1.74±0.67 [de]	51.04±5.98	16.58±6.24 [de]	38.47±2.94
Rebell/5%+50%	7.00±2.63 [ab]	54.40±7.55	63.40±27.05 [a]	43.40±6.67
Rebell/Lysodin	2.24±0.48 [cde]	49.33±6.62	18.44±6.01 [cd]	42.68±7.05
Rebell/Agar	2.58±1.30 [cde]	67.05±13.88	15.29±6.92 [de]	48.21±7.97
Rebell/SüsbinTMD	2.13±0.98 [cde]	65.24±14.44	17.53±5.52 [cd]	42.60±3.76
Rebell/SüsbinTMA	11.42±6.75 [a]	52.43±5.26	51.87±25.17 [ab]	42.13±2.48
Rebell/Süsbin	3.02±1.23 [cde]	41.98±9.72	21.17±6.18 [bcd]	37.27±3.61
Rebell/Stable	2.86±0.82 [bcd]	31.34±11.86	20.38±7.98 [cd]	48.92±7.79

Frick, Möhlin 1 and Sissach 5 orchards, 2005: Climatic conditions and flight period of *R. cerasi*

Climatic conditions during the experimental period are given in Annex III – Figure 2. Flight activity differed considerably among the three orchards: in the Frick orchard a total of 2049 flies was captured on the 16 traps. With 2157 flies on 16 traps, the flight activity was in a similar range in the Möhlin 1 orchard. In the Sissach 5 orchard, however, flight activity was 10 times lower (240 flies). In all three orchards, the peak flight activity was observed between

15 and 22 June 2005. Flight activity (number of flies per week) and proportion of females were similar in the beginning of the flight period (early captures) and over the whole flight period (total captures, Table 8, Table 9 and Table 10).

Frick, Möhlin 1 and Sissach 5 orchards, 2005: Effect of orchard

In these experiments, four trap/bait combinations were compared in each orchard: unbaited Rebell® traps, Rebell® traps with “Agar”-bait, Rebell® traps with Lysodin, and baited Frutect® traps. After pooling the data from the three orchards, only the orchard factor was found to have had a significant effect on the number of flies captured: in the Sissach 5 orchard, fewer flies were captured than in the other orchards (early captures; data transformed [$\log_{10}(x+1)$]; three-way ANOVA: trap/bait: $F_{3,41}=1.65$, $p=0.19$; trap location [south vs. southeast side of tree]: $F_{1,41}=3.57$, $p=0.07$; orchard: $F_{2,41}=52.26$, $p<0.001$; Student’s t-test $\alpha=0.05$; total captures; data transformed [$\log_{10}(x+1)$]; three-way ANOVA: trap/bait: $F_{3,41}=2.73$, $p=0.06$; trap location [south vs. southeast side of tree]: $F_{1,41}=2.37$, $p=0.13$; orchard: $F_{2,41}=47.66$, $p<0.001$; Student’s t-test $\alpha=0.05$; Table 8, Table 9 and Table 10).

Frick, Möhlin 1 and Sissach 5 orchards, 2005: Early captures of *R. cerasi*

Examining the data for each orchard separately, the trap/bait combination did not affect the average number of flies caught until two weeks prior to harvest in any orchard (early captures Frick; data transformed [$\log_{10}(x+1)$]; three-way ANOVA: trap/bait: $F_{3,8}=2.92$, $p=0.10$; trap location [south vs. southeast side of tree]: $F_{1,8}=5.50$, $p=0.05$; block: $F_{3,8}=11.32$, $p=0.003$; early captures Möhlin 1; data transformed [$\log_{10}(x+1)$]; three-way ANOVA: trap/bait: $F_{3,8}=1.85$, $p=0.22$; trap location [south vs. southeast side of tree]: $F_{1,8}=0.52$, $p=0.49$; block: $F_{3,8}=0.26$, $p=0.85$; early captures Sissach 5; data transformed [$\log_{10}(x+1)$]; three-way ANOVA: trap/bait: $F_{3,8}=1.38$, $p=0.32$; trap location [south vs. southeast side of tree]: $F_{1,8}=4.83$, $p=0.06$; block: $F_{3,8}=1.31$, $p=0.34$; Table 8, Table 9 and Table 10).

Frick, Möhlin 1 and Sissach 5 orchards, 2005: Total captures of *R. cerasi*

In terms of the number of flies captured per week over the whole experimental period, significant differences among the trap/bait combinations were observed only in the Frick orchard. Unbaited Rebell® traps captured significantly fewer flies than Rebell® traps with “Agar”-bait and Frutect® traps with Frutect® bait (total captures Frick; data transformed [$\log_{10}(x+1)$]; three-way ANOVA: trap/bait: $F_{3,8}=5.57$, $p=0.02$; trap location [south vs. southeast side of tree]: $F_{1,8}=3.31$, $p=0.11$; block: $F_{3,8}=13.81$, $p=0.002$; Student’s t-test $\alpha=0.05$; total captures Möhlin 1; data transformed [$\log_{10}(x+1)$]; three-way ANOVA: trap/bait: $F_{3,8}=2.27$, $p=0.16$; trap location [south vs. southeast side of tree]: $F_{1,8}=1.85$, $p=0.21$; block: $F_{3,8}=2.16$, $p=0.17$; total captures Sissach 5; data transformed [$\log_{10}(x+1)$]; three-way ANOVA: trap/bait: $F_{3,8}=1.61$, $p=0.26$; trap location [south vs. southeast side of tree]: $F_{1,8}=0.91$, $p=0.37$; block: $F_{3,8}=2.56$, $p=0.13$; Table 8, Table 9 and Table 10).

Orchards Frick, Möhlin 1 and Sissach 5, 2005: Proportion of females

The proportion of female flies was not affected by any measured factor in any of the orchards.

Table 8: Results of the 2005 experiment in the Frick orchard.

Frick orchard, 2005	Early captures (19 May to 22 June, 34 days)		Total captures (19 May to 13 July, 55 days)	
Trap / bait	Flies per week	% females	Flies per week	% females
Rebell/-	9.11±4.89 [n.s.]	44.79±4.15	8.43±4.50 [c]	39.51±2.94
Frutect/Frutect	27.90±11.31 [n.s.]	48.16±6.32	30.04±11.96 [a]	43.28±5.92
Rebell/Lysodin	10.76±2.47 [n.s.]	44.65±2.66	9.99±2.14 [bc]	42.52±3.35
Rebell/Agar	15.75±6.13 [n.s.]	42.25±5.26	16.74±6.54 [ab]	38.79±6.13

Table 9: Results of the 2005 experiment in the Möhlin 1 orchard.

Möhlin 1 orchard, 2005	Early captures (27 May to 22 June, 26 days)		Total captures (27 May to 13 July, 47 days)	
Trap / bait	Flies per week	% females	Flies per week	% females
Rebell/-	19.99±8.06 [n.s.]	49.49±6.48	15.90±6.41 [n.s.]	44.41±4.25
Frutect/Frutect	38.03±6.21 [n.s.]	45.33±0.31	28.89±4.61 [n.s.]	41.26±1.97
Rebell/Lysodin	24.97±4.42 [n.s.]	49.59±2.57	19.21±4.67 [n.s.]	45.26±1.99
Rebell/Agar	16.69±4.80 [n.s.]	48.75±2.89	16.31±2.46 [n.s.]	38.57±3.62

Table 10: Results of the 2005 experiment in the Sissach 5 orchard.

Sissach 5 orchard, 2005	Early captures (23 May to 22 June, 30 days)		Total captures (23 May to 13 July, 51 days)	
Trap / bait	Flies per week	% females	Flies per week	% females
Rebell/-	1.05±0.31 [n.s.]	32.44±14.80	1.34±0.31 [n.s.]	34.24±6.09
Frutect/Frutect	1.58±0.54 [n.s.]	54.09±15.33	1.99±0.44 [n.s.]	47.46±6.53
Rebell/Lysodin	2.22±0.49 [n.s.]	31.46±9.32	1.78±0.29 [n.s.]	32.53±8.48
Rebell/Agar	2.68±0.49 [n.s.]	48.73±5.18	1.32±0.31 [n.s.]	38.50±4.08

Eptingen orchard in 2006: Climatic conditions and *R. cerasi* emergence

Climatic conditions during the experimental period are given in Annex III – Figure 3. A total of 2713 flies was captured on the 36 traps over the whole experimental period in 2006.

Fly emergence was monitored using photo-electors. Eight unbaited Rebell® traps were used to monitor the flight activity as a part of the soil treatment experiments described in part C. Peak emergence was observed between 10 and 14 June 2006 (Figure 24). Fewer female (31%) than male flies were observed in the photo-electors. Peak flight activity was observed during the same period. However, a second peak flight activity occurred around 26 June. On the Rebell® traps, 48% of the captured individuals were females. Monitoring of emergence ended on 23 June. On the Rebell® traps considerable flight activity was observed until mid-July. The experiment was started eight days after beginning of the flight period (16 June 2006). As shown in Table 11, more flies per week were captured in the beginning of the flight period (early captures) than over the whole flight period (total captures).

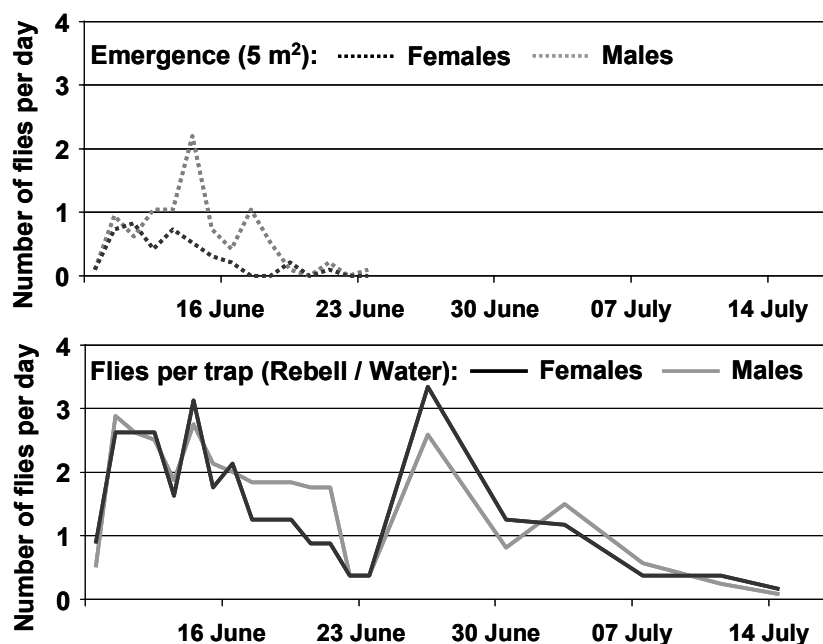

Figure 24: Fly emergence per 5 m² monitored by photo-electors and flight period monitored with Rebell® traps in the Eptingen orchard in 2006.

Eptingen orchard in 2006: Early captures of *R. cerasi*

The trap/bait combination had a significant effect on the number of flies captured until two weeks before harvest (data transformed [$\log_{10}(x+1)$]; two-way ANOVA: trap/bait: $F_{7,21}=12.25$, $p<0.001$; block: $F_{3,21}=8.51$, $p<0.001$; Student's t-test $\alpha=0.05$; Table 11). Compared to the standard Rebell® trap baited with water, the following baits resulted in significantly greater numbers of flies captured: Urevit, Fructect® bait, and TMA-card. No bait resulted in significantly greater catches than the standard bait (Fructect®). Nevertheless, compared to the Fructect® bait, the TMA-card resulted in a 25% increase in the number of flies caught.

Eptingen orchard in 2006: Total captures of *R. cerasi*

Similar effects were observed in terms of number of flies captured per week over the whole experimental period (data transformed [$\log_{10}(x+1)$]; two-way ANOVA: trap/bait: $F_{7,21}=11.43$, $p<0.001$; block: $F_{3,21}=6.03$, $p=0.004$; Student's t-test $\alpha=0.05$; Table 11). Compared to the standard Rebell® trap with water, the following baits resulted in significantly greater numbers of flies captured: Urevit, Fructect® bait, and TMA-card. No bait resulted in significantly greater catches than the standard bait (Fructect®). Nevertheless, compared to the Fructect® bait, the TMA-card resulted in a 11% increase in the number of flies caught.

Eptingen orchard in 2006: Proportion of females

Trap/bait combination had no effect on the proportion of female flies (early captures; data transformed [$\arcsin\sqrt{(x/100)}$]; two-way ANOVA: trap/bait: $F_{7,21}=0.22$, $p=0.98$; block: $F_{3,21}=21.03$, $p<0.001$; total captures; data transformed [$\arcsin\sqrt{(x/100)}$]; two-way ANOVA: trap/bait: $F_{7,21}=0.24$, $p=0.97$; block: $F_{3,21}=17.88$, $p<0.001$; Table 11).

Table 11: Results of the 2006 experiment in the Eptingen orchard.

Eptingen orchard, 2006	Early captures (16 June to 30 June, 14 days)		Total captures (16 June to 14 July, 28 days)	
	Flies per week	% females	Flies per week	% females
Rebell/Water	21.00±2.04 [bc]	48.83±7.51	14.25±1.45 [cd]	48.33±4.45
Rebell/Frutect	40.75±8.87 [a]	44.78±8.24	27.94±5.22 [a]	45.59±6.56
Frutect/Water	16.38±4.15 [c]	49.89±8.90	10.50±2.57 [d]	48.88±10.45
Frutect/Frutect	49.38±1.89 [a]	50.75±5.19	31.88±1.07 [a]	49.97±4.72
Rebell/Lysodin	25.25±3.92 [b]	49.33±6.45	17.13±1.83 [bc]	46.44±5.60
Rebell/SüsbinTMA	38.00±4.06 [a]	49.12±4.90	24.06±2.03 [ab]	49.10±0.41
Rebell/Süsbin	17.63±3.56 [bc]	48.60±9.81	11.69±1.96 [d]	45.52±8.25
Rebell/Urevit	50.86±12.00 [a]	50.89±9.16	32.13±8.14 [a]	49.60±8.16

D.3.3. Side effects of traps and baits on non-target arthropods

In 2006, the side effects of traps and baits were evaluated by counting the non-target arthropods one month after beginning of the experiments in the Frick, Möhlin 1 and Sissach 5 orchards. Identification to species level was not possible due to the difficulty in removing the insects from the sticky traps without damaging them.

Most of the non-target insects captured were **Diptera**. Because many small individuals (<5 mm) were captured, the coverage (% of trap surface covered by Diptera other than Syrphidae, Tachinidae or *Rhagoletis*) was estimated, rather than counting the exact number of individuals per trap. On average, 6.15% of the trap surface was covered with Diptera. Trap/bait combination, orchard and trap location had a significant effect on captures of Diptera (three-way ANOVA: trap/bait: $F_{3,41}=5.63$, $p=0.003$; trap location [south vs. southeast side of tree]: $F_{1,41}=6.42$, $p=0.02$; orchard: $F_{2,41}=4.26$, $p=0.02$; Tukey HSD test $\alpha=0.05$). Significantly more Diptera were captured on baited Frutect® traps (coverage 8.29±0.89%) than on any other trap/bait combination (coverage 5.19 to 5.77%). More Diptera were captured on the south side of the trees (coverage 6.82±0.65%) than on the southeast side (coverage 5.49±0.44%). Significantly more Diptera were captured in the Möhlin 1 orchard (coverage 7.34±0.78%) than in the Sissach 5 orchard (coverage 5.01±0.43%; Frick: 6.13±0.72%). As potentially beneficial insects, **Syrphidae** were counted separately. A total of 15 individuals was captured on 48 traps. Trap/bait combination had no effect on the number of Syrphidae captured (log-linear analysis: Deviance=4.226, $df=3$, $p=0.24$). Orchard and trap location had no effect on the number of Syrphidae captured. No **Tachinidae** were captured on the traps.

On 48 traps, 778 individuals of the order **Coleoptera** were captured, of which 103 individuals were *Phyllobius oblongus* (Curculionidae). *Agrius* sp. (Buprestidae) was also present in large numbers. Trap/bait combination had no effect on the number of Coleoptera captured. Orchard and trap location, however, had a significant effect on the numbers of Coleoptera per trap (three-way ANOVA: trap/bait: $F_{3,41}=0.86$, $p=0.47$; trap location [south vs. southeast side of tree]: $F_{1,41}=4.63$, $p=0.04$; orchard: $F_{2,41}=5.59$, $p=0.007$; Tukey HSD test $\alpha=0.05$).

Significantly more individuals were captured in the Sissach 5 orchard (21.88 ± 2.43 individuals per trap) than in the Frick (14.38 ± 3.94 individuals per trap) and in the Möhlin 1 orchards (12.38 ± 1.62 individuals per trap). More individuals were captured on the south side of the tree (19.75 ± 2.75 individuals per trap) than on the southeast side of the tree (12.67 ± 1.81 individuals per trap). The number of **Coccinelidae** captured was not affected by the trap/bait combination (two-way ANOVA: trap/bait: $F_{3,42}=0.94$, $p=0.43$; orchard: $F_{2,42}=15.42$, $p<0.001$; Tukey HSD test $\alpha=0.05$). Significantly more Coccinelidae were captured in the Möhlin 1 orchard (16.06 ± 2.13 individuals per trap) than in the Sissach 5 (6.00 ± 1.45 individuals per trap) and in the Frick orchards (3.19 ± 0.83 individuals per trap). Altogether, 404 individuals, mainly *Propylea 14-punctata*, were captured on 48 traps.

Only low numbers of **Neuroptera** were captured. A total of 10 Chrysopidae, 4 Hemerobidae and 3 Raphidioptera were captured on all traps. Trap/bait combination had no effect on the number of Neuroptera captured (log-linear analysis: Deviance=0.17, $df=3$, $p=0.98$). Orchard and trap location had no effect on the number of Neuroptera captured.

Special attention was given to certain sub-orders and families in the order **Hymenoptera**. A total of 281 individuals of **Ichneumonoidea** were captured on the 48 traps. Trap/bait combination had no effect. Orchard, however, had a significant effect on the numbers of Ichneumonoidea captured per trap (two-way ANOVA: trap/bait: $F_{3,42}=0.74$, $p=0.54$; orchard: $F_{2,42}=9.99$, $p<0.001$; Tukey HSD test $\alpha=0.05$). Significantly more individuals per trap were captured in the Frick orchard (9.44 ± 1.35) than in the Möhlin 1 (4.38 ± 0.62) and Sissach 5 orchards (3.75 ± 0.81). Most of the 91 **Apoidea** captured on the 48 traps were small wild bees. No bumble bees and only one honey bee were caught. No measured factor had any effect on the number of individuals captured (three-way ANOVA: trap/bait: $F_{3,41}=0.50$, $p=0.69$; trap location [south vs. southeast side of tree]: $F_{1,41}=1.16$, $p=0.29$; orchard: $F_{2,41}=0.65$, $p=0.53$). A total of 173 **Symphyta** was captured. The number of individuals was significantly different in the different orchards. Significantly more Symphyta were captured in the Frick orchard (7.56 ± 1.26) than in the Sissach 5 (1.75 ± 0.36) and Möhlin 1 orchards (1.50 ± 0.45 individuals per trap). Trap/bait combination had no effect on the number of captured Symphyta (two-way ANOVA: trap/bait: $F_{3,42}=0.34$, $p=0.80$; orchard: $F_{2,42}=15.68$, $p<0.001$; Tukey HSD test $\alpha=0.05$).

Similar effects were observed for the 265 **Hemiptera** captured on the 48 traps: trap/bait combination had no effect, whereas significant differences occurred among the orchards. Significantly more Hemiptera were captured in the Frick orchard (13.31 ± 4.42) than in the Sissach 5 (2.13 ± 0.83) and in the Möhlin 1 orchards (1.13 ± 0.31 individuals per trap; two-way ANOVA: trap/bait: $F_{3,42}=0.33$, $p=0.81$; orchard: $F_{2,42}=13.14$, $p<0.001$; Tukey HSD test $\alpha=0.05$).

Only 27 individuals of the order **Lepidoptera** were captured on all traps. Significantly fewer individuals were captured on the southeast side of trees (0.29 ± 0.09) than on the south side (0.83 ± 0.27 individuals per trap; log-linear analysis: trap location [south vs. southeast side of tree]: Deviance=6.53, $df=1$, $p=0.01$; orchard: Deviance=22.83, $df=2$, $p<0.001$; trap/bait: Deviance=11.35, $df=3$, $p=0.01$). Differences between orchards were also significant: no Lepidoptera were captured in the Möhlin 1 orchard. In the Frick orchard 1.00 ± 0.39 individuals per trap were captured; in the Sissach 5 orchard only 0.69 ± 0.37 individuals per trap were captured. Most individuals were captured on the Frutect® traps (1.00 ± 0.48), followed by the

unbaited Rebell® traps (0.67 ± 0.18), and by the Rebell® traps baited with "Agar"-bait (0.50 ± 0.26). The lowest number of individuals was captured on the Rebell® traps baited with Lysodin (0.08 ± 0.08 individuals per trap).

A total of 18 **Mecoptera** (*Panorpa sp.*) was captured. Significantly fewer individuals were captured on the southeast side of trees (0.17 ± 0.10) than on the south side (0.58 ± 0.24 individuals per trap; log-linear analysis: trap location [south vs. southeast side of tree]: Deviance=5.88, df=1, $p=0.02$; orchard: Deviance=31.83, df=2, $p<0.001$; trap/bait: Deviance=3.61, df=3, $p=0.31$). Differences between orchards were also significant: no Mecoptera were captured in the Sissach 5 orchard. In the Frick orchard 1.06 ± 0.34 individuals per trap were captured; in the Möhlin 1 orchard only 0.06 ± 0.06 individuals per trap were captured.

A total of 37 spiders (**Araneae**) was captured. The number of individuals was significantly different in the different orchards. Trap/bait combination, however, had no effect (log-linear analysis: orchard: Deviance=21.84, df=2, $p<0.001$; trap/bait: Deviance=5.46, df=3, $p=0.14$). In the Frick orchard significantly more spiders were captured (1.63 ± 0.31) than in the Möhlin 1 (0.44 ± 0.16) and the Sissach 5 orchards (0.25 ± 0.14 individuals per trap).

D.4. Discussion

The attractiveness of food baits to *R. cerasi* was evaluated using yellow sticky traps in combination with different baits. For effective control of *R. cerasi* – for an attract-and-kill strategy or for mass trapping purposes – the flies should be captured as soon as possible after emergence, preferably within the pre-oviposition period of about 10 days (Boller, 1966b) to avoid fruit damage. Flies captured only shortly before harvest or even after harvest are not relevant for rating the efficacy of traps and baits. Therefore, the discussion will focus on captures until two weeks prior harvest (early captures).

Performance of baits varied between the experimental years and between the experimental orchards. Therefore, only few general conclusions can be drawn from this series of experiments. Irrespective of year and locality, unbaited Rebell® traps performed better than unbaited Frutect® traps, capturing 1.3 to 2.5 times more *R. cerasi* of both sexes during the critical period. This shows the advantage of Rebell® traps over other trap types for cherry fruit fly attraction. Similar results were obtained by Katsoyannos et al. (2000) and Gajek & Olszak (1996): Rebell® traps were found to be more effective than other trap types.

Performance of newly developed baits

The bait made from 5% yeast hydrolysate and 50% ammonium acetate increased the number of flies by 47 to 50% compared to the Frutect® bait in two out of three experiments. In all experiments, this bait was among the best two baits tested. The bait made of 2.5% yeast hydrolysate and 10% ammonium acetate tended to capture fewer flies than the more concentrated bait. An ammonia-releasing substance was chosen as the main olfactory component for these baits. To ensure a slow release of ammonium over the whole flight period of *R. cerasi*, a buffer solution (pH 6.3) was used as a basis. Different authors state that ammonia-releasing substances are attractive to different *Rhagoletis sp.*: Frick (1952) captured 50 times more flies in traps with ammonium carbonate. He observed that *R. cingulata* flies near ammonium carbonate baited traps "appear agitated and excited. They walk around more rapidly than usual, fluttering their wings and making short, curving, rapid

flights generally towards the trap". Reissig (1976) noted that ammonia acetate increased the captures of *R. cingulata* on yellow sticky traps by 140%, whereas *R. fausta* showed no reaction. Pelz-Stelinski et al. (2005) confirmed these results by demonstrating that ammonium acetate lures on Rebell® traps more than doubled captures of *R. cingulata*. According to Casagrande et al. (1995) "increasing the quantity of ammonia being released improves attraction", which might explain the higher attractiveness of the 50%-concentrated bait. Vita et al. (1982) caught 50% more flies on traps baited with ammonium carbonate. For my experiments, I chose ammonium acetate based on the work of Katsoyannos et al. (2000), who showed that adding ammonium acetate to Rebell® traps increased the captures of *R. cerasi* by 50%, whereas ammonium carbonate had no significant effect. In addition to ammonium acetate, yeast hydrolysate was used as component of the baits, because Wiesmann (1944) hypothesized that the attractiveness of a bait might not only be due to the release of ammonia but mainly to other products of protein decomposition. Liburd et al. (2001), however, found that the addition of protein to an ammonium acetate bait did not increase captures of *R. cingulata*. Although the ammonium acetate bait was one of the best baits tested, it will probably not become commercially available because of the following points: (1) A liquid bait is difficult to handle and not appreciated by farmers. (2) The buffer makes the preparation of the bait rather expensive. (3) The efficacy of this bait is still too low to convince a company to start production.

The "Agar"-bait also contained ammonium acetate (9.5%) as a main component. Two other components – Trimethylamine (21%) and Diaminobutane (1%) – were added. The bait was formulated in agar as described by Robacker (1995) for *A. ludens*. He used ammonium carbonate, methylamine HCL and Diaminobutane in a 6:10:1 solution mixed with agar to increase the durability of the mixture. The "Agar"-bait increased captures by 38% compared to the Fructect® bait in the 2004 experiment. In the 2005 and 2006 experiments, captures were comparable to water-baited traps. Differences between the experiments can be attributed partly to differences in bait application: in 2004, the bait (100 ml) was poured into the plastic bottles hanging under the Rebell® traps. During experimental period, the bait shrunk to one sixth of its original volume. In 2005, the "Agar"-bait (20 ml) was shrink-wrapped in small plastic bags and placed under the Rebell® traps. This application, resulted in rather disappointing captures. Therefore, in 2006 the bait was again applied in the same fashion as in 2004. Captures, however, were again very low. The TMA-cards contain similar ingredients; however they are formulated as an impregnated cardboard rather than in agar. They captured 4.4 times more flies. The individual components of the "Agar"-bait tested separately were significantly less attractive than in combination. All three components captured equal numbers of flies. Mayer et al. (2000) also noted that ammonium acetate and diaminobutane formulated separately tended to capture fewer *R. indifferens* flies than in combination. In contrast, Katsoyannos et al. (2000) observed that adding Trimethylamine and Diaminobutane to the ammonium acetate did not increase captures of *R. cerasi*. The differences in the efficacy of "Agar"-bait observed in the different experimental years cannot be explained conclusively. Because a similar commercial formulation (TMA-card) is already available, there are no plans to make the "Agar"-bait commercially available.

The Urevit bait increased captures by 24% compared to the Fructect® bait. Urevit (urine processed by electro dialysis and subsequent ozonation as described by Pronk et al. (2007)) is still only being produced on a pilot scale. Pinero et al. (2003) evaluated urine – as a

naturally occurring, readily available substance – as bait for *Anastrepha* sp. to be used by resource-poor fruit growers in Mexico. They found that although urine significantly increased the number of captured flies, this bait was still less effective than baits containing hydrolyzed protein. Despite the good results, urine is not considered to be an acceptable bait due to possible consumer objections.

Performance of commercial baits

Adding Frutect® bait (RonPal Ltd., Rishpon, Israel) to Rebell® or Frutect® traps significantly increased the number of captured flies by 70 to 108% (Rebell® trap) and by 55 to 277% (Frutect® trap), respectively. No other bait resulted in significantly greater catches than the Frutect® bait. The Frutect® bait for olive fruit flies was slightly less effective than the Frutect® bait for cherry fruit flies. There were no significant differences compared to water-baited traps. The commercial bait Nu Lure (Intrachem Bio Italia S.p.A.) increased captures only 7% compared to water-baited Rebell® traps and the increase was not significant. Compared to the Frutect® bait, Nu Lure captured 55% fewer flies. A low efficacy of Nu Lure is also reported for captures of *R. completa* (Reynolds et al., 1996). The liquid organic fertilizer Lysodin Algafert (Intrachem Bio Italia S.p.A.) – containing hydrolyzed hides – showed variable efficacy. This bait was included in six experiments. Compared to water-baited traps, it increased captures by 78 and 111% in two experiments. In two other experiments, captures were only increased by 18 and 20%, and in the two subsequent experiments, captures were equal (+5%) or even lower (-20%) than in water-baited traps. The aforementioned baits – Frutect®, Nu Lure and Lysodin Algafert – contain protein hydrolysates. Obviously, the flies react differently to different protein hydrolysates. The exact compositions of the baits are corporate secrets and are thus not known. Reynolds et al. (1996) hypothesize that differences in attractiveness of protein baits might be due to different pH levels. The pH levels were not determined in my experiments.

The TMA-card marketed by the company Süsbin (Süsbin, Division agro de Quemar S.R.L.) captured 140% more flies compared to the Frutect® bait in the first experiment and showed a performance equal to the Frutect® bait in the second experiment. In both experiments, differences between water-baited traps and TMA-cards were significant. Due to the dry formulation and to the convenience in handling, this bait is probably the most suitable bait for cherry fruit fly control by mass trapping in home gardens or small scale production. For large-scale cherry production, however, this bait is too expensive at the present time.

The Trimedlure plugs (TMD), also marketed by the company Süsbin (Süsbin, Division agro de Quemar S.R.L.), did not increase captures compared to water-baited traps. Although highly attractive to males of *C. capitata* (Epsky & Heath, 1998), this kind of parapheromone does not elicit a reaction in *R. cerasi* – as demonstrated earlier by Haisch & Forster (1969). The bait for *R. cerasi* marketed by the company Biobest (Biobest N.V., Westerlo, Belgium) captured fewer flies than the water-baited traps. The bait for stable flies (Rescue!® Fly trap; Sterling International Inc., Spokane, WA, USA) was not effective in attracting *R. cerasi*: numbers caught did not exceed the numbers caught in the water-baited traps.

Proportion of female flies

About 50% of all captures were females, although their proportions varied between 31% and 70%. The mean value and the range of variance between years is consistent with the data in

the literature: Boller (1966b) and Prokopy (1969) mention a proportion of 50% females. In their laboratory experiments, Haisch (1975) and Haisch & Forster (1975) recorded 54% females and 60% females, respectively. Katsoyannos et al. (2000) captured 53% to 59% females on Rebell® traps in one experimental year, whereas in the following year 31% to 43% females were observed.

A higher proportion of females was captured in the beginning of the flight period than over the whole flight period. There are two possible reasons for this: (1) Female flies emerge a little earlier than males (Haisch, 1975) and might therefore be captured in higher proportions at the beginning of the flight period. (2) Young females need protein for egg maturation (Boller & Prokopy, 1976) and might therefore be more responsive to food baits. Toward the end of the flight period, females are mainly searching for fruit for oviposition and might become less responsive to food baits. A similar observation was made by Prokopy (1969).

Summarized over all trap/bait combinations, the proportion of females flies captured in Aesch in 2006 was about 10% lower than in the two previous years. The main reason for this was probably the very cool and rainy weather interrupting the 2006 emergence period. This obviously killed a large part of the fly population and resulted in total captures five times lower compared to the previous years. Due to their earlier emergence, females might have suffered more than males from these weather conditions. In addition, the estimation of the proportion of females might be less precise due to the lower total number of flies captured in 2006. For example, the high proportion of females (70%) calculated for the Fructect® trap baited with water is based only on a total number of 20 captured individuals. Although Fructect® traps baited with water tended to capture a higher proportion of females than Rebell® traps baited with water, the absolute number of females captured by Rebell® traps was always higher than the absolute number of females captured by Fructect® traps.

Position of traps within the tree canopy affected captures of females: traps on the southeast side captured more females (in proportion and in total numbers) than traps on the south side.

Side effects of traps and baits

The capture of non-target arthropods is undesirable for two reasons: (1) it leads to a reduction of beneficial insects and (2) captured non-target arthropods can substantially reduce the effectiveness of traps. Neuenschwander (1982) observed that 16 times more parasitoids and predators than olive fruit flies (*B. oleae*) were captured on yellow sticky traps in olive groves. He suggested that three to five yellow sticky traps per tree would be enough to eliminate all beneficial insects from an olive tree.

Most non-target insects captured on the yellow traps were Diptera. Similar observations were made by many authors (Howitt & Connor, 1965; Prokopy, 1974; Trottier et al., 1974; Thomas, 2003). Prokopy (1974) noted that many of the captured Diptera were Tachinidae. However, no Tachinidae were observed on the traps in my experiments. Trap type and bait only affected the numbers of other Diptera captured on the traps. No effect was found for any other group of arthropods. In contrast to my results, Howitt & Connor (1965) observed that the most effective baits for *R. pomonella* also captured the highest number of non-target insects. In contrast, Thomas et al. (2001) and Thomas (2003) noted that a synthetic bait containing ammonium acetate and diaminobutane attracted fewer non-target insects.

Differences between the three orchards were more pronounced and might be attributed to different cultivation practices. Traps suspended over an uncut meadow (Frick orchard) captured a much greater variety of insects. The grass was more than 1 m high during the experimental period. Consequently, more phytophagous insects (Symphyta, Hemiptera, Lepidoptera) were captured in this orchard. Ichneumonoidea, Araneae and Mecoptera were also present in higher numbers. Sheep were kept in the Sissach 5 orchard and the grass was mulched regularly under the trees in the Möhlin 1 orchard. The high number of Coccinellidae captured in the Möhlin 1 orchard might have been due to a heavy black cherry aphid (*Myzus cerasi*; Homoptera: Aphididae) infestation in the neighbouring, young cherry trees of the variety Kordia.

In order to minimize captures of non-target arthropods, attention should be paid to the following points: (1) The meadow under the cherry trees should be cut two or three days before trap placement. (2) Traps should be installed on the southeast side of the canopy, as traps on the southeast side of the trees captured less Diptera, Coleoptera, Lepidoptera and Mecoptera. In addition, traps placed in the southeast part of the canopy captured higher numbers of female *R. cerasi*.

Flight period and flight activity of *R. cerasi*, cherry varieties

Peak flight activity always occurred around mid-June and was mainly affected by weather conditions. In 2006, peak flight activity was similar in the Aesch and Eptingen orchards, although the Eptingen orchard is situated at a 350 m higher altitude than the Aesch orchard. Differences were found when the emergence period and the flight period were compared: emergence lasted two to three weeks, whereas the flight period lasted five to seven weeks. This indicates that most flies were not captured immediately after emergence. In mark and release experiments, young *R. completa* also showed an unexpected delay in responsiveness to food-based lures and yellow sticky traps (Reynolds et al., 1996). Additional, more detailed research is needed to evaluate the dynamics of fly behaviour after emergence until capture.

An effect of cherry variety on the number of flies was observed in some years. This effect, however, was inconsistent between years. Generally, the captures were highest in the early ripening varieties (Star) at the beginning of the flight period. Over the whole flight period, traps in the late ripening varieties (Schauenburger) tended to capture more flies.

Significantly fewer flies were captured on trees without yield. In trees with low yield, however, the flight activity was similar to that in trees with normal yield. Wiesmann (1934b) observed that flies leave the trees if they cannot find enough fruit for oviposition.

Conclusions & recommendations

Although some baits were able to double the number of captured flies, the response of the flies to the different baits was rather low. More effective traps and baits are needed in order for their application to be economical. Wiesmann (1944) hypothesized that cherry fruit flies find enough food (nitrogen sources) within the trees and are thus not highly attracted to food baits. Haisch & Forster (1969) also observed a weak response of cherry fruit flies to olfactory baits. Baits were most effective in combination with yellow coloured traps (Haisch & Forster, 1969; Haisch & Forster, 1970; Katsoyannos et al., 2000), which led most authors to conclude

that yellow colour is more attractive to cherry fruit flies than olfactory baits (Boller, 1969; Haisch & Forster, 1970; Boller & Prokopy, 1976; Katsoyannos et al., 2000).

Two traps per tree were used in my experiments. In 2004, a total of 12145 cherry fruit flies was captured in the Aesch orchard, which had nearly no impact on the population. A total of 9566 flies was captured in the same orchard in 2005. A higher number of traps per tree is therefore needed to control cherry fruit flies by mass trapping. In addition, the number of traps should be in proportion to the size of the tree. Boller (1969) showed that out of 7000 released flies, only 18.6% were recaptured on yellow sticky traps. He used 350 traps in an orchard of 900 trees. Remund & Boller (1983) suggest using one to eight Rebell® traps, depending on the size of tree, on the southeast side of the canopy. With bait, half the number of traps may suffice. However, four traps per tree are still too many to be economically feasible. Too much labour is involved, especially as the traps should be hung in the upper part of the canopy. Traps and baits are therefore not a suitable method for controlling cherry fruit flies in commercial production or for establishing an effective attract-and-kill system.

In small-scale backyard production and home gardens, however, mass trapping of cherry fruit flies might be a possibility. For mass trapping in home gardens, the Rebell® traps in combination with the TMA-card are considered to be the best method, as liquid baits are difficult to handle. The use of a liquid bait in combination with the Fructect® trap is especially complicated: The opening in the red sphere is rather small and filling the trap with bait is difficult and time consuming. Moreover, liquid baits often spill during transport and installation and while in the field, which is rather unpleasant due to the strong smell. In addition, the Fructect® trap is very susceptible to wind. A gentle breeze is enough, to cause the Fructect® trap to rotate about its own axis, causing leaves to stick to the trap or even causing the trap to fall. In addition, the Fructect® trap and Fructect® bait are not available in Switzerland. Therefore, the TMA-card is the most effective bait currently available. The formulation of this bait allows a quick, easy and clean installation. When yellow sticky traps are used, attention should be paid to the following points: (1) The grass under the cherry trees should be cut two to three days before trap placement. (2) Traps should be placed on the southeast side. (3) Leaves should be removed around the traps to expose them to full sun.

Part E – Foliar applications of mycopesticides for controlling *R. cerasi*

E.1. Introduction

The pathogenicity and virulence of different entomopathogenic fungi on different life stages of *R. cerasi* were evaluated in previous laboratory experiments. Adult flies were found to be the only life stage susceptible to fungus infection. *B. bassiana* ATCC 74040 showed a high virulence (part A). Therefore, foliar applications using this fungus isolate, which is formulated in the commercial product Naturalis-L (Intrachem Bio Italia), were evaluated in five field trials in 2006 and 2007. *I. fumosorosea* Apopka 97 also showed a good efficacy in laboratory experiments. This fungus isolate, formulated in the commercial product PreFeRal®WG (Biobest N.V. Belgium), was included in one of the experiments.

The aim of these trials was to transfer the good laboratory results into a field application strategy. Foliar applications of entomopathogenic fungi focusing on adult *R. cerasi* were applied in order to reduce infestation levels in cherries.

E.2. Materials & methods

E.2.1. Applications of mycopesticides in 2006 and 2007

Experimental orchards

In 2006, the trials were conducted in the orchards Sissach 2 and Sissach 4. In 2007, the experiments were set up in the orchards Sissach 2, Sissach 3, and Eptingen. Locations of orchards are given in Annex I. In the previous years, only yellow sticky traps were used to control *R. cerasi* in these orchards.

The Sissach 2 orchard consisted of 30 young standard cherry trees (planted in 2000) of the varieties Dolleseppler (16 trees), Schauenburger (six trees), Wölflisteiner (four trees), Hollinger (two trees), and Waadt (two trees). An examination of flight activity over the last two years indicated that *R. cerasi* did not show a preference for any one variety. The trees were approximately 3.5 m tall and yielded 2 to 2.5 kg cherries each. The trees were arranged in a long with 10 m spacing between trees. The trial was arranged in randomized block design with five replicates (three trees per plot). Details on experimental design are given in Annex II – Figure 11.

The Sissach 3 orchard consisted of 28 young standard cherry trees (planted in 1999) of the varieties Dolleseppler (26 trees) and Wölflisteiner (two trees). The trees were approximately 3.5 m tall and yielded 2 to 2.5 kg cherries each. The trees were arranged in two rows with 10 m spacing between trees. The trial was arranged in randomized block design with four replicates (two trees per plot). Details on experimental design are given in Annex II – Figure 12.

The Sissach 4 orchard consisted of 21 young standard cherry trees (planted in 2000) of the varieties Dolleseppler (18 trees) and Wölflisteiner (3 trees). The trees were approximately 3 m tall and yielded 0.5 to 1 kg cherries each. The orchard was arranged in five rows with three to seven trees each at intervals of 10 m in each direction. This orchard was treated with sulphur on 26 May 2006. No other pesticide treatment was applied. The trial was arranged in

randomized block design with seven replicates (one tree per plot). Details on experimental design are given in Annex II – Figure 13.

The Eptingen orchard consisted of 26 semi-intensively managed standard cherry trees (planted in 1976) of the varieties Dolleseppler (eight trees), Langstieler (nine trees), Schauenburger (seven trees), and Rote Lauber (two trees, not included in the trial). The trees were approximately five metres tall and yielded 15 to 25 kg cherries each. The orchard was arranged in six rows with two to eight trees each at intervals of 7 to 14 m in each direction. The trial was arranged in a block design with seven replicates (one tree per plot). Details on experimental design are given in Annex II – Figure 14.

Treatments

B. bassiana ATCC 74040 (product: Naturalis-L; Intrachem Bio Italia S.p.A.; trials in 2006: Lot no. 6001 14/03/06; trials in 2007: Lot no. 6004 14/12/06) was applied in all experiments. *I. fumosorosea* Apopka 97 (product: PreFeRal®WG, Biobest, Belgium; Lot no. 52806.2) was only applied in the Sissach 4 orchard in 2006. In order to evaluate the effect of additives used in the formulation of the product Naturalis-L, one treatment using only the additives of Naturalis-L was applied in the Sissach 3 orchard in 2007. Untreated trees served as a control. The fungus isolates were applied at a concentration of 5.75×10^4 CFU ml⁻¹ to runoff (3 l per tree in the Sissach 2, 3 and 4 orchards; 15 l per tree in the Eptingen orchard) using a commercial high-pressure hand-held gun. CFU concentrations for the products were adjusted by dilution with tap water according to the concentrations given in the package instructions (250 ml Naturalis-L per 100 l; 2.88 g PreFeRal®WG per 100 l). The beginning of the flight period was determined by using yellow sticky traps. The first application was made within five days after the first fly captures. Four treatments at seven day intervals were applied in the Sissach 2, 3, and 4 orchards. Two strategies were compared in the Eptingen orchard: intensive application of Naturalis-L at seven day intervals (five treatments) and extensive application of Naturalis-L at 14 day intervals (two treatments). The last application was made seven to 14 days before harvest. Details on application dates are given in Table 12.

Measurements

Flight period and flight activity of *R. cerasi* were monitored using one yellow sticky trap per tree (Rebell® amarillo; Andermatt Biocontrol AG, Grossdietwil, Switzerland). Details on the monitoring period are given in Table 12. Traps were checked at weekly intervals. In 2006, the flies were removed from the traps, placed on moist peat, and incubated at 23°C as described in part A in order to confirm mycosis. The reliability of this method was evaluated in preliminary laboratory tests. It was shown that this method is unsuitable for a quantitative assessment of infestation level. Especially for flies trapped at an early stage of infection, the fungus often failed to grow out during incubation. Trapped flies probably die too rapidly for the fungus to develop. However, this method allows a qualitative assessment of the pathogenicity of the fungi to *R. cerasi* under field conditions.

Fruit infestation was assessed at harvest. The cherries were dissected under a binocular microscope to estimate *R. cerasi* infestation level. The numbers of all larval instars and damaged fruit, already abandoned by larvae going into pupation were assessed. Sample

size varied, depending on the total yield of the trees. Sampling date varied depending on the ripening dates of the various cherry varieties. Details are given in Table 12.

Statistical analysis

Normality of data and homogeneity of variance were tested before performing an ANOVA. If necessary, data were transformed. The number of flies per trap and the infestation rate of cherries were analysed for each orchard separately by one- or two-way ANOVA [treatment, variety]. Pooled data from all five experiments (treatments Naturalis-L and control) were analysed by three-way ANOVA [treatment, orchard, year]. Means were compared using Tukey HSD post hoc tests ($\alpha=0.05$). Unless mentioned otherwise, the data presented in the tables and the text are means with standard errors. The correlation between efficacy (% , Abbott's formula) and the number of days between the last application and sampling was calculated.

Table 12: Monitoring period, application and sampling dates and sample size in the 2006 and 2007 experiments.

2006		2007		
Sissach 2	Sissach 4	Sissach 2	Sissach 3	Eptingen
Monitoring of flight activity				
From 17 May to 06 July 2006	From 05 June to 06 July 2006	From 10 May to 27 June 2007	From 10 May to 27 June 2007	From 10 May to 04 July 2007
Application dates				
05 June 2006	05 June 2006	23 May 2007	16 May 2007	23 May 2007
12 June 2006	12 June 2006	30 May 2007	23 May 2007	30 May 2007*
19 June 2006	19 June 2006	06 June 2007	30 May 2007	06 June 2007
26 June 2006	26 June 2006	13 June 2007	06 June 2007	13 June 2007*
				20 June 2007
Sampling dates				
06 July 2006	06 July 2006	20 June 2007 ⁽¹⁾	20 June 2007	27 June 2007 ⁽³⁾
		27 June 2007 ⁽²⁾		02 July 2007 ⁽⁴⁾
				04 July 2007 ⁽⁵⁾
Sample size				
75 cherries / tree	50 cherries / tree	50 cherries / tree	75 cherries / tree	200 cherries / tree

* Application dates for extensive application strategy of Naturalis-L; ⁽¹⁾ varieties Dolleseppler, Wölfisteiner, Waadt; ⁽²⁾ varieties Schauenburger, Hollinger; ⁽³⁾ variety Langstieler; ⁽⁴⁾ variety Dolleseppler; ⁽⁵⁾ variety Schauenburger

E.2.2. Persistence of fungal propagules on the phylloplanes

To estimate the survival time of fungal propagules on cherry leaves, leaf samples were taken immediately after the first treatment, and one, three, and seven days after the first treatment in the orchards Sissach 2 and Sissach 4 in 2006. One leaf sample consisted of 10 leaves. Three samples per fungus isolate and orchard were analysed in the laboratory. Leaf samples were cooled down immediately after sampling, transported to the laboratory, stored at 4 to 7°C and analysed four days later. Due to logistics and time needed, the samples could not be analysed the same day. Leafstalks were removed and leaves were roughly cut with scissors and weighed. From each sample, 5 g were taken, homogenized in 100 ml demineralised water containing 0.05% Tween®80 (Merck-Schuchardt, Hohenbrunn,

Germany) with a blender (Ika Ultra Turrax T18 basic) at 22000 rpm for 20 sec and filtered through Nylon mesh (0.4 mm mesh size) under vacuum. The suspensions obtained from the samples immediately and one day after treatment were diluted 1:10, the samples taken three days after treatment were diluted 1:5, the samples taken seven days after treatment remained undiluted. Of each suspension, 100 µl were spread plated on selective medium in petri dishes (described in part A) with a Trigalsky spatula (2 petri dishes per sample). After incubation at 22°C for 10 days, the number of colonies was counted and the number of CFU g⁻¹ leaf was calculated. To identify fungus colonies based on morphological criteria, some petri dishes were inoculated with a suspension of the two products Naturalis-L and PreFeRal®WG. These cultures were compared to the fungus colonies obtained from the leaf samples. To evaluate the effect of cold storage of leaves during for four days until processing, an additional sample (20 leaves per tree) was taken immediately after application in Sissach on 19 June 2006. Ten leaves were processed as described above on the same day, and 10 leaves were analysed after four days of cold storage. The data on the effect of cold storage on the number of CFU were [\sqrt{x}] transformed and analysed by two-way ANOVA [treatment, storage, treatment*storage].

Single branches on the south side of three cherry trees (variety Langstieler) in the Frick orchard were treated on 13 July 2007. Because the batch of PreFeRal®WG used for this experiment had been stored in the refrigerator for more than a year, the density of CFU in both products was determined in April 2007 by spread plating dilution series of Naturalis-L (Lot no. 6004, 14/12/06) and PreFeRal®WG (Lot no. 52806.2). The number of CFU was 1.47x10⁹ CFU g⁻¹ in the product PreFeRal®WG (concentration given in package instructions: 2x10⁹ CFU g⁻¹) and 1.73x10⁸ CFU ml⁻¹ for Naturalis-L (concentration given in package instructions: 2.3x10⁷ CFU ml⁻¹). For field application, the concentration for both products was adjusted to 5x10⁵ CFU ml⁻¹ using 2.6 ml Naturalis-L per litre and 0.34 g PreFeRal®WG per litre. Branches were treated to runoff. Leaf samples (15 leaves per sample) were taken immediately after treatment, and one, three, seven, and 14 days after treatment. Leaves were analysed in the laboratory as described above within two hours after sampling. The number of CFU g⁻¹ leaf was calculated. The number of CFU ml⁻¹ tank mixture was determined by spread plating 100 µl of 1:10³ diluted tank mixture.

E.3. Results

E.3.1. Applications of mycopesticides in 2006 and 2007

Climatic conditions and flight period of *R. cerasi* in 2006 and 2007

The climatic conditions are given in Annex III – Figure 3 and 4. In the 2006 experimental period (5 June – 6 July; Annex III – Figure 3), the relative humidity averaged 68.1%, with high humidity levels during the night (RH_{max}: 99%), appearance of dew in the early morning, and low humidity during the afternoon (RH_{min}: 29.0%). Temperature averaged 19.2°C, with low temperatures during the night (T_{min}: 6.8°C) and high temperatures during the afternoon (T_{max}: 31.0°C). Over the whole experimental period, a total precipitation of 59.8 mm was recorded. Average global radiation was 6.6 kWh m⁻² per day.

The *R. cerasi* flight started in the first week of June and strongly increased in the Sissach 4 orchard during the subsequent warm and sunny days (peak flight activity: 10 to 26 June). Flight activity remained at a low level in the Sissach 2 orchard, possibly due to intense wind.

The Sissach 2 orchard is located on a hill exposed to wind, whereas the Sissach 4 orchard is in a valley protected from the wind. The first application of fungus products was made on 05 June 2006. The following days were sunny and increasingly warm. A second application was made seven days later, under hot and sunny weather conditions. A week later after two rainy days, the third application was made on 19 June 2006. The last application was made on 26 June 2006, after 15 mm of rain. These four applications covered the whole flight period of *R. cerasi*.

In 2007 (16 May – 4 July; Annex III – Figure 4), less sunlight and clearly more rain were recorded. The relative humidity averaged 81.0%, with high humidity levels during the rainy periods and during the night (RH_{\max} : 100%) and low humidity during the afternoon (RH_{\min} : 40%). The temperature averaged 15.9°C, with low temperatures during the night (T_{\min} : 2.6°C) and high temperatures during the afternoon (T_{\max} : 28.1°C). Over the whole experimental period a total precipitation of 281.2 mm was recorded. Average global radiation was 5.1 kWh m⁻² per day.

In the Sissach 2 and Sissach 3 orchards, the *R. cerasi* flight started in mid-May (23 May and 12 May, respectively) and remained at a very low level until the end of June. In the Eptingen orchard, which is located at a higher altitude, the flight period started on 23 May, reached a peak in mid-June (13 to 20 June) and decreased at the end of June. The first application of fungus products was made on 16 May 2007 in the Sissach 3 orchard. One week later on 23 May, the first treatments were applied in the Sissach 2 and Eptingen orchards. Although the overall experimental period was very wet and rainy, all treatments were applied under dry conditions. No rain occurred during or within five hours after the applications. Heavy rains occurred frequently one day after application, however.

Flight activity and mycosis

The cumulative number of flies caught per trap during the experimental periods is given in Table 13. No differences between treatments were found in any experiment. In all experiments, however, traps in treated trees tended to catch fewer flies. Pooling the data for the Naturalis-L treatment and the control over all experiments, the differences in number of flies per trap were significant (three-way ANOVA, data transformed [$\log_{10}(x)$]; treatment: $F_{1,49}=5.56$, $p=0.02$; orchard: $F_{3,49}=143.41$, $p<0.001$; year: $F_{1,49}=35.17$, $p<0.001$). Traps in Naturalis-L treated trees caught significantly fewer flies than traps in control trees. Differences between the orchards and the two years of the experiment were also significant.

In Eptingen, the number of flies per trap was significantly affected by cherry variety: traps in the variety Dollesepler caught significantly more flies (153.0 ± 16.7 flies per trap) than traps in the varieties Langstieler (72.4 ± 12.6) and Schauenburger (62.0 ± 4.0 ; two-way ANOVA [treatment, variety]; variety: $F_{2,16}=16.90$, $p<0.001$, Tukey HSD-Test $\alpha=0.05$; treatment: $F_{2,16}=0.32$, $p=0.23$).

The percentage of mycosis in flies caught on sticky traps was only examined in 2006. An infection of flies under field conditions was possible. Mycosis was clearly higher in treated plots (Table 13). A morphological comparison with mycosed flies from laboratory trials indicated that the mycosis was due to *B. bassiana* and *I. fumosorosea*.

Table 13: Summarized results of field application experiments with mycopesticide.

Year / Orchard	2006 / Sissach 2	2006 / Sissach 4	2007 / Sissach 2	2007 / Sissach 3	2007 / Eptingen
<i>Average number of flies per trap</i>					
Control	6.7±0.7 [n.s.]	11.0±2.3 [n.s.]	1.6±0.4 [n.s.]	4.0±1.4 [n.s.]	115.9±18.3 [n.s.]
Naturalis-L	4.4±1.1 [n.s.]	6.0±0.8 [n.s.]	1.1±0.1 [n.s.]	3.1±0.9 [n.s.]	94.6±26.2 [n.s.]
PreFeRa@WG		7.6±1.5 [n.s.]			
Naturalis-L Additives				1.8±0.3 [n.s.]	
Naturalis-L Extensive					90.0±18.1 [n.s.]
Statistical analysis, (data transformed: $[\log_{10}(x)]$)	one-way ANOVA, treatment: $F_{1,8}=4.62$, $p=0.06$	two-way ANOVA, treatment: $F_{2,15}=2.66$, $p=0.10$; variety: $F_{1,15}=0.01$, $p=0.92$	one-way ANOVA, treatment: $F_{1,8}=1.07$, $p=0.33$	one-way ANOVA, treatment, $F_{2,9}=0.48$, $p=0.64$	two-way ANOVA, treatment: $F_{2,16}=0.32$, $p=0.23$, variety: $F_{2,16}=16.90$, $p<0.001$
<i>Mycosis of flies (%)</i>					
Control	1.4±1.4	1.9±1.9			
Naturalis-L	7.2±3.1	8.9±4.8			
PreFeRa@WG		22.6±11.0			
<i>Fruit infestation (%)</i>					
Control	9.7±0.9 [a]	14.3±3.7 [a]	3.9±1.5 [n.s.]	1.3±0.8 [n.s.]	17.1±3.1 [a]
Naturalis-L	2.5±1.3 [b]	4.3±1.3 [b]	1.2±0.5 [n.s.]	0.5±0.3 [n.s.]	8.8±3.7 [b]
PreFeRa@WG		10.0±3.0 [ab]			
Naturalis-L Additives				0.5±0.3 [n.s.]	
Naturalis-L Extensive					13.5±3.2 [ab]
Statistical analysis (data transformed: $[\arcsin\sqrt{x}]$)	one-way ANOVA, treatment: $F_{1,8}=16.63$, $p=0.004$	two-way ANOVA, treatment: $F_{2,15}=6.62$, $p=0.009$; variety: $F_{1,15}=9.60$, $p=0.007$	one-way ANOVA, treatment: $F_{1,8}=1.67$, $p=0.23$	one-way ANOVA, treatment: $F_{2,9}=0.26$, $p=0.78$	two-way ANOVA, treatment: $F_{2,16}=7.37$, $p=0.005$; variety: $F_{2,16}=21.05$, $p<0.001$
<i>Efficacy of Naturalis-L (%; Abbott's formula)</i>					
Efficacy	74.2	69.9	69.2	61.5	48.5 (18% - 78%)*

(* Considerable differences between varieties: see text)

Fruit infestation level

The fruit infestation level differed considerably between the orchards and years. Pooled data from all experiments for the Naturalis-L treatment and the control revealed significant effects of the factors treatment, orchard and year (three-way ANOVA, data transformed [$\arcsine\sqrt{x}$]); treatment: $F_{1,49}=20.68$, $p<0.001$; orchard: $F_{3,49}=13.19$, $p<0.001$; year: $F_{1,49}=4.12$, $p=0.047$). Examining the experiments separately, Naturalis-L (applied in seven day intervals) significantly reduced the infestation rate in all experiments in which there was $>4\%$ infested fruit in the untreated control (Table 13). No significant differences could be detected in orchards with low infestation levels (Sissach 2 and Sissach 3 orchards in 2007). No significant differences were found between the control and the treatments PreFeRal®WG, Additives of Naturalis-L, and extensive application of Naturalis-L, respectively. In four out of five experiments, the efficacy (Abbott's formula; (Abbott, 1925) of Naturalis-L ranged between 62% and 74%. In the 2007 experiment in Eptingen the overall efficacy of Naturalis-L was only 49%.

In this experiment, the different cherry varieties showed significantly different rates of infested fruit: the number of infested cherries in the variety Schauenburger ($23.6\pm 2.9\%$ infested fruit) was significantly higher than in the varieties Langstieler ($11.9\pm 6.0\%$) and Dolleseppler ($6.4\pm 3.0\%$). Calculated separately for each variety, the efficacy of Naturalis-L was 78% in the variety Langstieler, 73% in the variety Dolleseppler, and 18% in the variety Schauenburger. Interactions [treatment x variety] were not significant and therefore not included in the final statistical model (Table 13). Fruit samples from the three varieties in Eptingen were taken at 7, 12, and 14 days after the last application, respectively. Based on the data from all five experiments, a negative correlation was found between efficacy and days until harvest (Efficacy calculated according to Abbott; linear regression: [efficacy= $128.7-5.9*\text{days}$]; $R^2=0.57$; $F_{1,5}=6.60$; $p=0.05$). Efficacy increased with shorter time interval between the last application and harvest.

E.3.2. Persistence of fungal propagules on the phylloplanes

During the 2006 experimental period (5 June to 12 June), the temperature averaged 15.8°C . Relative humidity averaged 53.9%. Average global radiation was 7.6 kWh m^{-2} per day. No rain occurred. A total of 882 fungus colonies was obtained from the leaf samples. Ten colonies were identified as *Penicillium sp.*; all other colonies (872) were *B. bassiana* and *I. fumosorosea*. A few colonies of bacteria were found, but not counted or identified. The number of CFU g^{-1} leaf on the different sampling dates is given in Table 14. In the sample taken immediately after application in the PreFeRal®WG treated plots, 275 times less living fungal propagules were found than in the Naturalis-L treated plots. A high variability was observed within the different PreFeRal®WG samples. Three days after application, no living fungal propagules could be detected in PreFeRal®WG treatment. On the Naturalis-L treated trees, living fungal propagules could still be detected seven days after application. However, a rapid decline was observed. Only 15.1 to 20.7% and 0.5 to 1.8% of the fungal propagules were still active one day and seven days after application, respectively.

Four days of cold storage led to a significant, 43% reduction of CFU on leaves (two-way ANOVA [product, storage, product*storage]; Data transformed [\sqrt{x}]); storage: $F_{1,8}=19.73$, $p=0.002$; product: $F_{1,8}=102.96$, $p<0.001$; product*storage: $F_{1,8}=0.1$, $p=0.76$). The differences

between the two products were also significant: On Naturalis-L (*B. bassiana*) treated leaves without cold storage, 17.5×10^4 CFU g^{-1} were counted, whereas only 4.5×10^4 CFU g^{-1} were found on PreFeRal®WG (*I. fumosorosea*) treated leaves. Cold storage seemed to have a stronger effect on *I. fumosorosea* (69% reduction of CFU after four days of cold storage) than on *B. bassiana* (37% reduction of CFU). However, interactions between fungus isolate and storage were not significant.

Table 14: Number of CFU g^{-1} leaves (\pm se) and percent CFU compared to the first sampling date in the Sissach 2 and 4 orchards in 2006 and in the Frick orchard in 2007.

Location	Treatment	directly after treatment	1 day after treatment	3 days after treatment	7 days after treatment	14 days after treatment
Sissach 4, 2006	Control	0 \pm 0	0 \pm 0	0 \pm 0	0 \pm 0	
	Naturalis-L	$9.2 \pm 0.8 \times 10^4$ (100%)	$13.9 \pm 2.1 \times 10^3$ (15.1%)	$4.4 \pm 1.4 \times 10^3$ (4.8%)	$0.50 \pm 0.35 \times 10^3$ (0.5%)	
	PreFeRal®WG	$0.03 \pm 0.03 \times 10^4$	$0.3 \pm 0.3 \times 10^3$	0 \pm 0	-	
Sissach 2, 2006	Control	0 \pm 0	0 \pm 0	0 \pm 0	0 \pm 0	
	Naturalis-L	$11.5 \pm 2.4 \times 10^4$ (100%)	$23.8 \pm 2.3 \times 10^3$ (20.7%)	$5.1 \pm 0.4 \times 10^3$ (4.5%)	$2.0 \pm 0.6 \times 10^3$ (1.8%)	
Frick, 2007	Control	$0.1 \pm 0.08 \times 10^4$	0 \pm 0	0 \pm 0	0 \pm 0	0 \pm 0
	Naturalis-L	$3.4 \pm 0.7 \times 10^4$ (100%)	$9.5 \pm 3.2 \times 10^3$ (27.9%)	$4.1 \pm 1.3 \times 10^3$ (12.1%)	$1.1 \pm 0.6 \times 10^3$ (3.2%)	$0.9 \pm 0.4 \times 10^3$ (2.7%)
	PreFeRal®WG	$2.8 \pm 0.3 \times 10^4$ (100%)	$13.2 \pm 3.7 \times 10^3$ (48.1%)	$2.8 \pm 1.1 \times 10^3$ (10.2%)	$0.5 \pm 0.3 \times 10^3$ (1.7%)	$0.3 \pm 0.2 \times 10^3$ (1.0%)

In order to obtain more precise information, single branches of three trees were treated with the two products in 2007. Each treatment was present on each of the three trees. Samples were analysed without cold storage. A period of fine weather was forecast before starting the experiments. During the first three days weather conditions were comparable to 2006 (sunny; temperature 22.8°C; relative humidity: 66.5%; global radiation: 7.8 kWh m^{-2} per day; no rain). Days four to seven were cloudy with little rain (temperature 21.7°C; relative humidity: 76.0%; global radiation: 5.6 kWh m^{-2} per day; sum of precipitation 9.1 mm). Days eight, 10 and 11 were very rainy. From day eight to day 14 there was a total of 85.9 mm of precipitation. Temperature averaged 18.2°C, relative humidity 79.6%, global radiation 5.5 kWh m^{-2} per day. Over the whole experimental period in 2007 (13 July – 27 July), the relative humidity averaged 73.1%, temperature averaged 19.5°C, and average global radiation was 5.8 kWh m^{-2} per day. Total precipitation was 95.0 mm. The number of CFU g^{-1} on the different sampling dates is given in Table 14. The analysis of the tank mixtures showed densities of 5.7×10^5 CFU ml^{-1} for the PreFeRal®WG treatment and 4.0×10^5 CFU ml^{-1} for the Naturalis-L treatment. In the leaf sample taken immediately after treatment, PreFeRal®WG

showed slightly lower CFU densities. However, CFU degradation was similar for Naturalis-L and PreFeRal®WG. For both products, living fungal propagules could still be detected 14 days after application. However, a rapid decline was observed. Only 27.9 to 48.1% and only 1.0 to 2.7% of CFU were still active one day after application and 14 days after application, respectively. Few fungus colonies were obtained from control leaves.

E.4. Discussion

Foliar applications of *Beauveria bassiana* (product Naturalis-L) in seven day intervals significantly reduced the number of infested fruit by 60 to 70%. The results were obtained from five experiments in two years with considerably different weather conditions and in different orchards with different flight intensities of *R. cerasi*. The other treatments tested (PreFeRal®WG, additives of Naturalis-L and extensive application regime of Naturalis-L) were less effective.

Flight activity monitored by yellow sticky traps was only slightly affected by treatments. This result is not surprising, as flies remain active during three to four days post exposure and might be trapped during this time.

An infection of flies under field conditions was shown to be possible. Mycosis was clearly higher in treated plots than in control plots. A morphological comparison with mycosed flies from laboratory trials indicated that the mycosis observed in the field trials was most likely due to *B. bassiana* and *I. fumosorosea*. The less than 2% mycosed flies found in the control plots probably migrated from treated plots.

Climatic conditions have major impact on the efficacy of mycopesticides. A temperature of 20 to 25°C is considered to be the optimum for development of entomopathogenic fungi. Above 35°C and below 15°C, development is limited (Inglis et al., 2001; Dimbi et al., 2004; Devi et al., 2005). In my field trials, the average temperature was below the optimum (19.2°C in 2006 and 15.9°C in 2007). Considering only the temperature, conditions were more favourable for fungus development in 2006 than in 2007.

High levels of humidity are needed for germination of conidia and for sporulation on cadavers. Doberski (1981), Walstad et al. (1970) and Gillespie (1988) found that the germination of conidia was reduced when relative humidity was below 95%. However, the microclimate is considered to be more important than the ambient environment. Shipp et al. (2003) noted that the infection rate of insects on leaves was higher than the infection rate of insects in petri dishes at the same ambient humidity. They hypothesize that a zone of high humidity (boundary layer) exists in immediate proximity to the leaf surface. This idea is supported by Wraight et al. (2000), who showed that an infection of *Bemisia argentifolii* Bellows & Perring (Hemiptera: Aleyrodidae) with *B. bassiana* and *I. fumosorosea* on leaves was possible at a relative humidity of 25 to 54%. In the laboratory trials (part A), a high infection level was observed at 60% relative humidity in cages without host plants. Inglis et al. (2001) and Wraight et al. (2000) stated that sufficient moisture even exists within the microenvironment of the host's body surface. In my field trials the relative humidity was higher (68.1% in 2006 and 81.0% in 2007) than the humidity during the laboratory experiments. Considering only the relative humidity, conditions were more favourable to fungus development in 2007 than in 2006.

Another crucial factor is sunlight. According to Inglis et al. (1995) and Daoust & Pereira (1986), sunlight is the most important parameter limiting survival of conidia in epigeal habitats. UV-B radiation in particular has a detrimental effect on micro-organisms (Smits et al., 1997; Ulevicius et al., 2004). Smits et al. (1997) stated that it took a greater amount of solar UV-B radiation in the field to produce the same effect on *I. fumosorosea* as achieved indoors with artificial radiation. A similar observation was made by Ignoffo (1992): when exposed to simulated sunlight in the laboratory, the half-life of conidia of *B. bassiana* ranged from 1.9 to 2.0 hours, whereas a half-life of two to three days was observed under natural sunlight. He hypothesized that highly reactive radicals produced by near-ultraviolet irradiation are primarily responsible for reducing persistence. This statement is supported by the observation that the decline of viable conidia in the lower part of the canopy is slower than in the upper parts, which are more exposed to the sun (Inglis et al., 1993; James et al., 1995). In the 2006 experiments, leaf samples were taken from all parts of the tree canopy. As the trees were quite small, I assumed that the samples were representative of the whole tree canopy. In 2007, samples were taken from branches on the south side of the cherry trees, as flies are also mainly active on the south side of the trees. In the experiments in 2006, a faster degradation of CFU per leaf was observed than in 2007. It is not clear whether these differences were due to the higher global radiation observed in the experimental period in 2006 or whether the cold storage of leaf samples before analysis in 2006 distorted the results. Fungus colonies obtained from control leaves in 2007 most likely resulted from drift during application, as leaf samples for the treatment and the control were taken from the same trees. No rain occurred in either the 2006 leaf sampling period or in the first three days of the 2007 experimental period. Therefore, fungal propagules were not washed off but, degraded by UV.

Within 24 hours after application, 52 to 70% of the original inoculum was lost and 90% was degraded three days after treatment. However, living fungal propagules could still be detected 14 days after treatment. Other studies show a broad range of variation in persistence of fungal propagules on leaves: On tomato fruit the persistence of *B. bassiana* under field conditions ranged from 32.4 to 48.6 hours (Karabrantanal & Awaknavar, 2005). Gardner et al. (1977) found that one-half of the activity of *B. bassiana* was lost five to 10 days after treatment, whereas James et al. (1995) noted that 10% of the original inoculum of *B. bassiana* was still present after 28 days under mild and wet field conditions. According to Inglis et al. (1993), temperature, relative humidity, and rainfall do not have an overriding impact on the survival of *B. bassiana* conidia. They found a 75 to 90% reduction of conidia on alfalfa within four days, whereas on wheatgrass activity was reduced by more than 99% within four days. Kouassi et al. (2003) found a conidia persistence and infectivity of *B. bassiana* of up to 26 days on foliage of lettuce and celery, with substantial differences between plant species. They reasoned that host plant characteristics can significantly affect persistence of conidia, and therefore efficacy of pest control with fungi on phylloplanes may be dependent on plant type.

The differences observed in 2006 between PreFeRal®WG and Naturalis-L might be due to formulation: Naturalis-L contains conidia of *B. bassiana* in an oil formulation, whereas PreFeRal®WG contains blastospores of *I. fumosorosea* formulated as water dispersible granules. Formulation might influence persistence on the leaves as well as the resistance of leaf samples to cold storage. In 2007, without cold storage of leaf samples, no differences

between PreFeRal®WG and Naturalis-L were observed. Although Inglis et al. (1993) stated that the persistence of conidia in oil was not significantly different from that of conidia formulated in water-Tween or a 5% oil emulsion, an adaptation of formulation might improve efficacy.

CFU concentrations in tank mixtures were adjusted according to concentrations given in the package instructions. However, spread plated samples from the products revealed that both products contained higher CFU densities than indicated in the instructions. Concentrations applied in treatments were therefore higher and slightly different between the treatments (13.1×10^5 CFU ml⁻¹ Naturalis-L in 2006; 4.3×10^5 CFU ml⁻¹ Naturalis-L in 2007; 5.9×10^5 CFU ml⁻¹ PreFeRal®WG in 2006). When kept in the refrigerator until application, no loss in CFU concentration below the level given in the package instructions was observed. Nevertheless, products must still be treated with care especially during shipment and storage.

To evaluate whether contact with treated leaves is sufficient to cause mycosis, two branch cage trials were conducted in 2007. Branches of cherry trees were treated with the products Naturalis-L and PreFeRal®WG. After the treatment layer had dried, branch cages made from fine mesh netting containing 10 to 15 flies and a water supply were installed. Five branches per treatment served as replicates. After three days the branches were cut, taken to the laboratory, and dead and surviving flies were retrieved from the branch cages. Results, however, were difficult to interpret. In the first experiment (conducted under humid weather conditions; 7.5 mm rain during three days), 77% of the flies in the untreated control died. Mortality was similar in treated plots. Many of the dead flies (60% in PreFeRal®WG treatment, and 80% in Naturalis-L treatment) showed signs of mycosis when placed on moist peat. The second experiment was conducted under sunny and warm conditions (maximum temperature: 33°C). Although flies had a water supply in the branch cages, nearly 50% of the flies in the control cages died during field exposure and another 40% of the flies disappeared. Mortality was lower (20%) and disappearance was higher (50 to 55%) in treated plots. Mycosis was observed on 17% of the dead flies in PreFeRal®WG treatment, and on 7% of the dead flies in the Naturalis-L treatment. No mycosis occurred in the control. As neither predators nor holes were found in the field cages, the reasons for the disappearance of the flies cannot be explained. Too few flies remained to evaluate mortality in the laboratory.

A significant effect of cherry variety on number of flies per trap as well as on fruit infestation was observed in the orchard in Eptingen: most flies were trapped on the variety Dolleseppler, and the fewest in the variety Schauenburger. Infestation level, however, was highest in the variety Schauenburger and lowest in the variety Dolleseppler. This was perhaps due to the different structure of the cherry trees: trees of the variety Schauenburger were very compact with dense, dark green leaves, whereas trees of the variety Dolleseppler were slender, with rather sparse, small and yellowish leaves. In addition, the variety Dolleseppler yielded many small fruit hanging in clusters, whereas the variety Schauenburger yielded fewer, bigger fruit, rather hidden beneath the leaves. The more open tree tops of the variety Dolleseppler might have made traps more visible. The lower number of fruit in the variety Schauenburger might have contributed to higher percent infestation levels. Fimiani (1989) noted similar discrepancies between number of flies per trap and percent infestation level.

In the 2007 experiment in Eptingen, the efficacy of Naturalis-L treatments in the variety Schauenburger (18% efficacy) was considerably lower than in the varieties Langstieler (78%) and Dolleseppler (73%). The low efficacy in the variety Schauenburger was most likely due to the extended period between last application and harvest (14 days). A negative correlation was found between efficacy and number of days from last application until harvest. The shorter the time between last treatment and harvest, the greater was the efficacy. This observation was supported by the distribution of larval instars found in the variety Schauenburger: more than 50% of the larvae found in Naturalis-L treated cherries were in the L₁ or L₂ instar, whereas only 4% of larvae in the treated cherries of the variety Dolleseppler were in the L₁ or L₂ instar. This observation is remarkable and difficult to explain. In the laboratory experiments, the median survival time of treated flies was shown to be five to seven days. In addition, larvae start hatching six to 10 days after oviposition, depending on temperature (Wiesmann, 1933b). Thus, within one week before harvest, treatments focused on adult flies should have had no effect on number of larvae. Based on these considerations, applications early in the flight period were considered to be important in order to kill the flies during the pre-oviposition period. All experiments were therefore started immediately after the beginning of the flight period. However, applications until shortly before harvest seem necessary for good efficacy. However, the correlation between efficacy and days between treatment and harvest should not be over-interpreted, as it is only based on seven data points. Further research is needed to find the best application strategy and to clarify this point.

In conclusion, the results show that an infection of adult flies under field conditions is possible. The formulation of Naturalis-L is suitable to keep the conidia of *B. bassiana* viable for more than seven days. However, more than 70% of the original inoculum degraded within 24 hours after application. Therefore, repeated applications seem necessary. With applications at seven day intervals, the fruit infestation was reduced by 60 to 70%. Nevertheless, the market tolerance for infested cherries (maximum 2% infested fruit) was still exceeded. However, for more than 10 years only yellow sticky traps were used to control *R. cerasi* in the experimental orchards, which led to high infestation pressure. With well-timed applications of Naturalis-L in succeeding years, it might be possible to lower the population level below the economic threshold. Further research is needed to determine (1) if applications in subsequent years are able to lower the infestation to a tolerable level; (2) if the formulation of the entomopathogenic fungi might be improved and (3) if better adapted application regimes can increase efficacy.

Part F – Repellent and oviposition deterrent effect of oil products and of Naturalis-L

F.1. Introduction

Oviposition behaviour of cherry fruit flies is influenced by host fruit characteristics, such as size, shape (Wiesmann, 1937b), colour (Boller, 1968), texture (Katsoyannos, 1975), surface structure (Wiesmann, 1937b), and chemosensory stimuli (Katsoyannos, 1975; Levinson & Haisch, 1983; Boller et al., 1998). Katsoyannos (1975) noted that duration of oviposition was six times longer in green and hard cherries than in fruit of optimal ripeness. Observing the flies during oviposition gives the impression that much effort is required to penetrate the fruit (Wiesmann, 1937b). Therefore, the question arose as to whether a mechanical barrier on the fruit surface could prevent oviposition. Oil products, such as formulated rape oil or Naturalis-L, which contains oil as additive, produce an oily film on the fruit surface after application. The effect of oil treatments on the oviposition behaviour of *R. cerasi* was evaluated in three experiments: a laboratory experiment, a semi-field experiment and a field experiment. The experiment under laboratory conditions focused on evaluating the general effect of rape oil and Naturalis-L on oviposition rate. In the semi-field experiment, the field persistence and degradation of oil products were investigated. In the field experiment, the efficacy of rape oil treatments in reducing fruit infestation was examined.

The aim of the experiments was to evaluate the possible repellent or oviposition deterrent properties of oil products and of formulation additives of Naturalis-L.

F.2. Materials & methods

F.2.1. Laboratory experiment

Field collected *R. cerasi* were used for the laboratory experiment. Flies originated from pupae collected in Hottwil AG and Eptingen BL in 2005. Collection procedure, settings of the climate chamber, and experimental cage size are given in part A. Each cage contained two female flies and one male fly. Flies were 23 to 31 days old at the beginning of the experiment. To ensure a high oviposition pressure, the flies were not provided with any oviposition sites prior to the experiments.

Cherries of the variety Dolleseppler at the stage of colour change from green to yellow were obtained from the northwest side of a cherry tree in the Eptingen orchard. Cherries were washed, and a sample of fruit was retained to estimate the initial infestation with *R. cerasi* eggs. Cherries for the experiment were treated to run-off (4 ml per replicate) using hand-held, air-assisted spraying equipment (Devilbiss SRI 510, 1 bar). The following products were applied at a concentration of 0.25%: Naturalis-L (Intrachem Bio Italia S.p.A.), sterile Naturalis-L (autoclaved at 121°C for 15 minutes) and rape oil (Telmion, Omya AG, Oftringen, Switzerland). After the product coating had dried, the cherries were exposed to *R. cerasi*. Four cherries were hung in the middle of each cage (replicate). Cherries were changed daily and the number of eggs was counted using a binocular microscope (6.3x magnification). The experimental design comprised four cages (replicates) of the following treatments: control (no-choice; four untreated cherries per cage); Telmion (no-choice; four Telmion treated cherries per cage); Naturalis-L (no-choice; four Naturalis-L treated cherries per cage); sterile

Naturalis-L (no-choice; four cherries per cage treated with sterile Naturalis-L); Choice (one cherry of each of the four aforementioned treatments). The experiment was stopped after four days to avoid a direct effect of *B. bassiana* on the flies.

The average number of eggs per cherry per day was calculated. Data were $[\log_{10}(x+1)]$ transformed. Normality of data and homogeneity of variance were tested before performing an ANOVA. The number of eggs per cherry per day were analysed by two-way ANOVA [product, choice/no-choice]. Means were compared by Tukey HSD post hoc tests ($\alpha=0.05$). The data presented in the figure are means with standard errors.

F.2.2. Semi-field experiment

Field collected *R. cerasi* were used for the semi-field experiment. Flies originated from pupae collected in Hottwil AG in 2006. Collection procedure, settings of the climate chamber, and experimental cages are described in part A. Each cage contained six female flies and two male flies. At the beginning of the first experiment, flies were five to 10 days old. For the second experiment, 14 to 17 day old flies were used. To ensure a high oviposition pressure, the flies were not provided with any oviposition sites prior to the experiments.

In contrast to the laboratory experiment, treatments were not applied indoors, but on fruit on the trees. Each treatment was applied to run-off on two branches of one tree (one branch on the north side and one branch on the south side). Fruit samples were taken immediately and three, six, and nine days after treatment. Two cherries – one from each side of the tree provided with water supply – were exposed to the flies in the laboratory for 48 hours. The number of eggs was counted using a binocular microscope (6.3x magnification). Dead flies in the cages were replaced. Flies were kept for 24 hours without oviposition sites before the next fruit were exposed.

The experiment was replicated twice: the first experiment was conducted using cherries of the variety Star at the stage of colour change from green to yellow from the Frick orchard (application date: 18 May 2007), the second experiment was conducted using cherries of the variety Schauenburger at the same stage from the Eptingen orchard (application date: 13 June 2007). The experimental design of the **first semi-field experiment** comprised five cages (replicates) of the following treatments: untreated control, Telmion 0.3% (Omya AG, Oftringen, Switzerland, rape oil; concentration 0.3%), Telmion 1% (concentration 1%), Genol Plant 1% (Syngenta Agro AG, Dielsdorf, Switzerland, rape oil; concentration 1%), Mineral oil 1% (Omya AG, Oftringen, Switzerland, mineral oil; concentration 1%), Promanal 1% (W.Neudorff GmbH KG, Emmerthal, Germany, paraffin oil; concentration 1%), Additives of Naturalis-L 1% (additives of Naturalis-L without conidia of *B. bassiana* obtained from Intrachem Bio Italia S.p.A.; concentration 1%). The experimental design of the **second semi-field experiment** comprised five cages (replicates) of the following treatments: untreated control, Telmion 1% (rape oil; concentration 1%), Telmion 1% mixed with Nufilm 0.1% (Intrachem Bio Italia S.p.A., Pinolene, concentration 0.1%), Telmion 1% mixed with Heliosol 0.1% (Omya AG, Oftringen, Switzerland, Pinolene, concentration 0.1%), Genol Plant 1% (rape oil; concentration 1%), Mineral oil 1% (mineral oil; concentration 1%), Additives of Naturalis-L 1% (concentration 1%).

The average number of eggs per cherry per day was calculated. Data were $[\log_{10}(x+1)]$ transformed if necessary. Normality of data and homogeneity of variance were tested before

performing an ANOVA. The number of eggs per cherry per day were analysed by one-way ANOVA. Means were compared by Tukey HSD post hoc tests ($\alpha=0.05$). The data presented in the figure are means with standard errors.

F.2.3. Field experiment

The field experiment was conducted in the Eptingen orchard in 2006. The location of the orchard is given in Annex I.

The orchard consisted of 26 semi-intensively managed standard cherry trees (planted in 1976) of the varieties Dolleseppler (eight trees), Langstieler (nine trees), Schauenburger (seven trees), and Rote Lauber (two trees, not included into trial). The trees were approximately five metres tall and yielded 15 to 25 kg cherries each. The orchard was arranged in six rows with two to eight trees each at intervals of 7 to 14 m in each direction. The trial was arranged in a randomized block design with four replicates (one tree per plot; three replicates of the variety Schauenburger, one replicate of the variety Langstieler). Details on experimental design are given in Annex II – Figure 15. In previous years only yellow sticky traps had been used to control *R. cerasi* in this orchard.

Rape oil (product: Telmion, Omya AG, Oftringen, Switzerland) was sprayed to run-off (15 l per tree) at a concentration of 1% using a commercial high-pressure hand-held gun. Untreated trees served as the control. Fly emergence was monitored daily by photo-electors. Flight period and flight activity were monitored by yellow sticky traps. The first application was made on 21 June 2006, seven days after peak emergence (14 days after the beginning of the flight period). Two additional applications were made on 26 June 2006 and on 3 July 2006. Fruit samples were taken immediately before the first application in order to estimate the initial infestation of cherries. Fruit infestation was assessed at harvest on 11 July (variety Langstieler) and on 14 July (variety Schauenburger). A sample of 200 cherries was taken from each tree. The fruit were dissected under a binocular microscope to estimate the infestation level by *R. cerasi*. The numbers of all larval instars and damaged fruit already abandoned by larvae for pupation were assessed.

Normality of data and homogeneity of variance were tested before performing an ANOVA. The infestation rate of cherries was analysed by two-way ANOVA [treatment, variety]. The data presented in the text are means with standard errors.

F.3. Results

F.3.1. Laboratory experiment

Cherries for the experiment were taken from the shady northwest side of the tree canopy, as it was assumed that this fruit would have the lowest initial infestation level. Nevertheless, 20 to 25% of fruit already contained *R. cerasi* eggs (initial infestation). Oviposition rate was significantly reduced by the treatments, although no differences were found between the different products. Whether or not the flies had the choice between treated and untreated cherries had no significant effect on oviposition rate (Data transformed [$\log_{10}(x+1)$]; two-way ANOVA: product: $F_{3,27}=18.70$, $p<0.001$; choice/no-choice: $F_{1,27}=3.04$, $p=0.09$; Tukey HSD test $\alpha=0.05$; Figure 25).

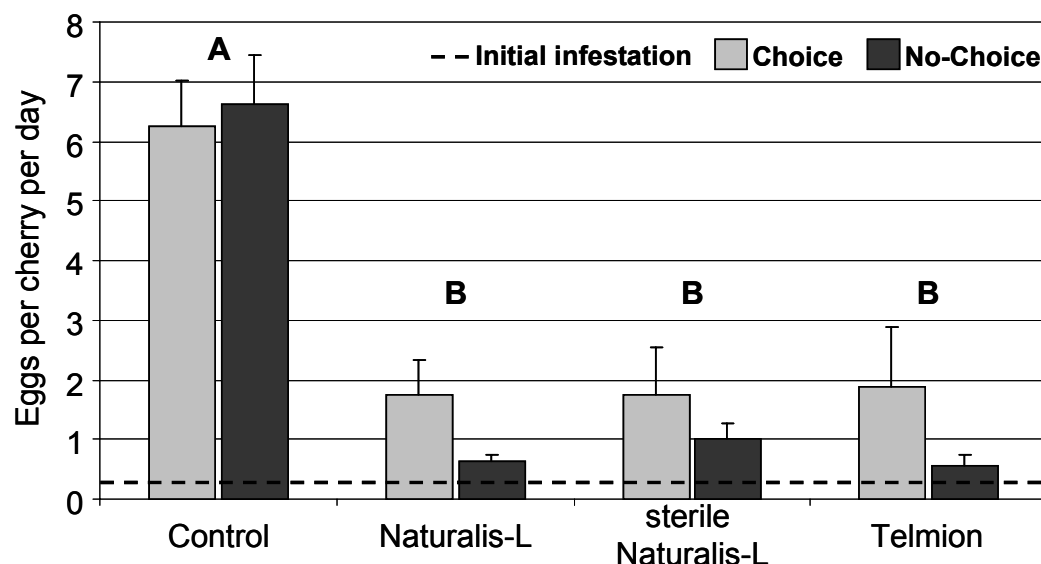

Figure 25: Oviposition deterring effect of Naturalis-L, sterile Naturalis-L and rape oil (Telmion) in the laboratory experiment: Number of eggs per day (\pm se) in differently treated cherries.

F.3.2. Semi-field experiment

Climatic conditions during the experimental period are given in Annex III – Figure 4. The results of the first semi-field experiment are given in Figure 26. Immediately after treatment (0d), the oviposition rate was significantly reduced by all treatments – except for Telmion 0.3% (data transformed $[\log_{10}(x+1)]$; one-way ANOVA: $F_{6,28}=15.92$, $p<0.001$; Tukey HSD test $\alpha=0.05$). Three days after treatment (3d), a significant effect was only observed for the treatments Telmion 1% and Promanal 1% (data transformed $[\log_{10}(x+1)]$; one-way ANOVA: $F_{6,28}=7.88$, $p<0.001$; Tukey HSD test $\alpha=0.05$). Six days and nine days after treatments, no differences were found between any of the treatments and the untreated control (data transformed $[\log_{10}(x+1)]$; one-way ANOVA: six days after treatment: $F_{6,28}=2.37$, $p=0.06$; nine days after treatment: $F_{6,28}=1.40$, $p=0.25$). The weather was sunny (average temperature 19.2°C , $T_{\min}=6.5^{\circ}\text{C}$, $T_{\max}=30.0^{\circ}\text{C}$) during the experiment. Slight precipitation (14 mm) occurred in the night from day three to day four. Promanal caused phytotoxicity: small black spots on the lower end of the fruit caused by product droplets remaining after runoff. This product was thus not included in the second semi-field experiment.

In the second semi-field experiment, Telmion was tested in combination with the pinolene products Heliosol and Nufilm to enhance stability. The results of this experiments are given in Figure 27. Immediately after treatment (0d), the oviposition rate was significantly reduced by all products except Telmion 1% and the additives of Naturalis-L 1% (data transformed $[\log_{10}(x+1)]$; one-way ANOVA: $F_{6,28}=10.33$, $p<0.001$; Tukey HSD test $\alpha=0.05$). After this first fruit sampling and before sampling on the third day of the experiment, 52.9 mm of rain occurred. Between the sampling on day three and on day six, another 38.1 mm of rain was recorded. Thus, climatic conditions during this experiment differed considerably from those during the first experiment (average temperature 19.3°C , $T_{\min}=11.2^{\circ}\text{C}$, $T_{\max}=30.4^{\circ}\text{C}$). No differences were found between any product and the untreated control three and six days after application (one-way ANOVA: three days after treatment: $F_{6,28}=0.95$, $p=0.47$; six days after treatment: $F_{6,28}=0.92$, $p=0.49$).

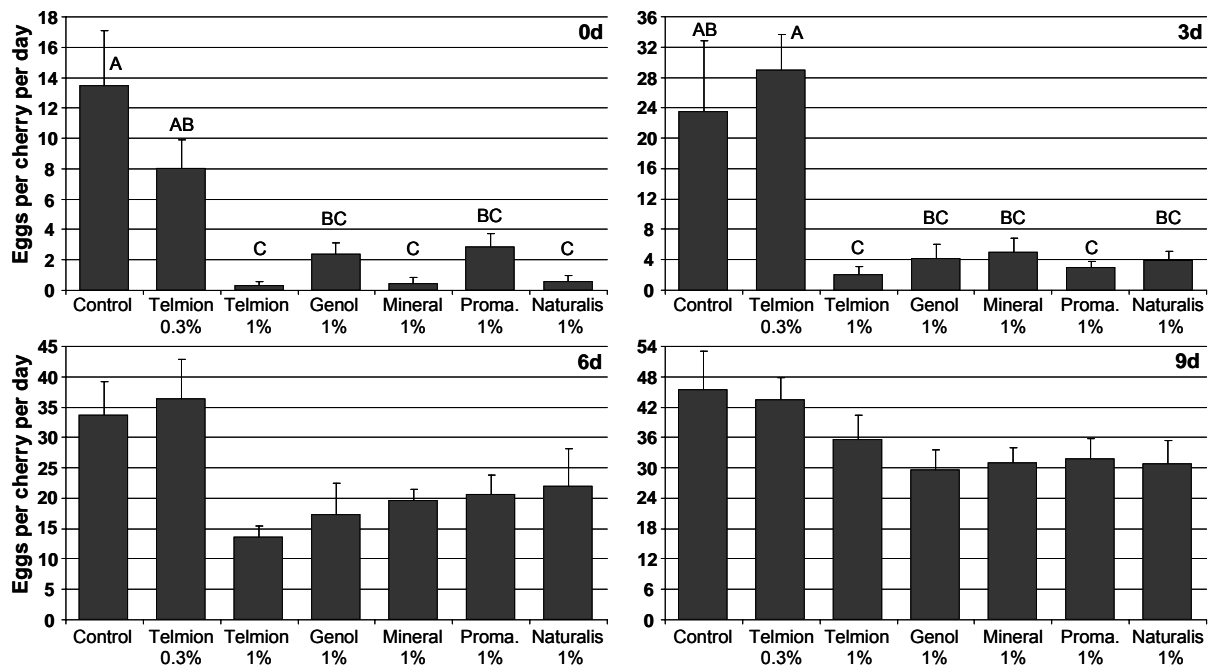

Figure 26: Oviposition deterring effect of oil products in the first semi-field experiment: Number of eggs per day (\pm se) in differently treated cherries, fruit samples taken immediately (0d), three, six, and nine days after treatment.

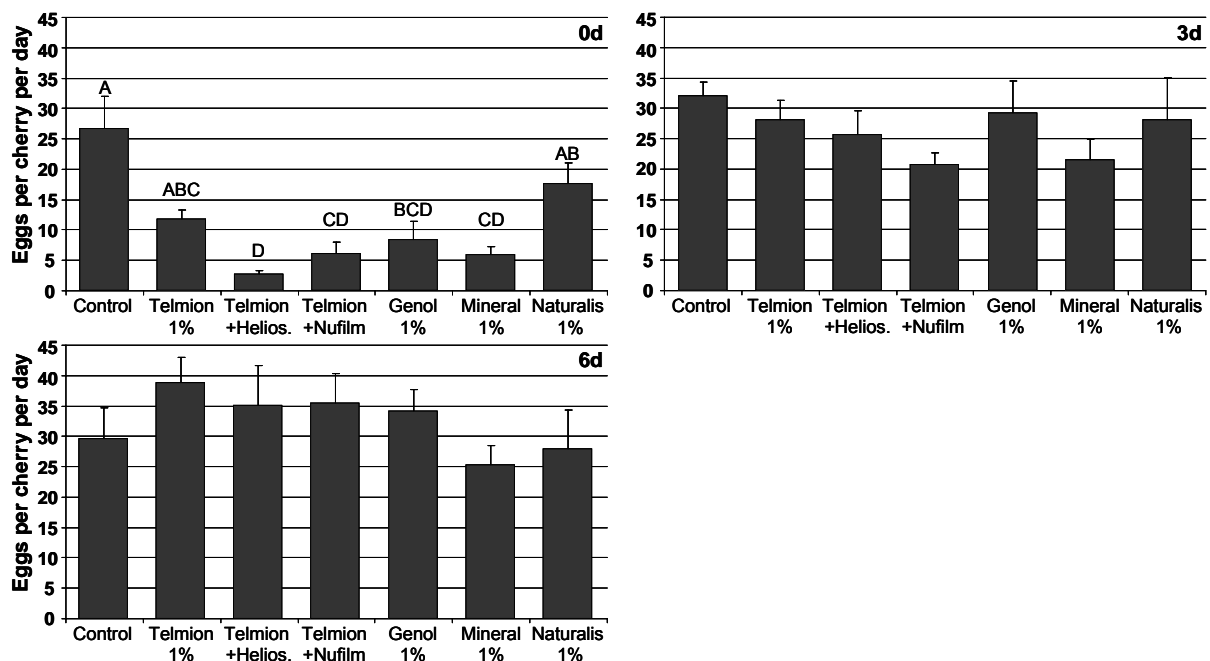

Figure 27: Oviposition deterring effect of oil products in the second semi-field experiment: Number of eggs per day (\pm se) in differently treated cherries, fruit samples taken immediately (0d), three, and six days after treatment.

F.3.3 Field experiment

Climatic conditions during the experimental period are given in Annex III – Figure 3. Four days after the first application, 11.4 mm of rain occurred. Therefore, a second application was made five days after the first one. A third application was made one week later after 6.8 mm of rain. Fruit samples taken before the first application showed that 5.8% of the cherries already contained eggs. Infestation level at harvest was $41.5 \pm 4.82\%$ in the control

trees and $27 \pm 5.68\%$ in the Telmion treated trees. Differences were not significant (two-way ANOVA: treatment: $F_{1,5}=4.56$, $p=0.09$; variety: $F_{1,5}=2.22$, $p=0.20$).

F.4. Discussion

Oil products have an oviposition deterring effect on *R. cerasi*. Observations of the behaviour of the flies in the laboratory experiments showed that flies frequently landed on treated fruit and started their typical oviposition behaviour (Katsoyannos, 1975). However, due to the slippery, oily surface, the flies were not able to penetrate the skin with the ovipositor. The attempt at oviposition was interrupted for a cleaning of tarsae, followed by a new attempt at oviposition. If flies were only supplied with treated cherries, this behaviour was often observed for more than an hour. The observation of repeated attempts to oviposit in treated fruit suggests that the oviposition deterring effect is mainly due to a mechanical barrier and not to the flies reacting to non-host volatiles, as observed for soy protein (Cirio & Vita, 1975) and *Cornus*-extract treated fruit (Levinson & Haisch, 1983). This observation is in contrast to the observations made for *B. tryoni*: the flies were repelled as soon as their tarsae came in contact with oil treated surfaces and they did not try to oviposit into oil treated fruit (Nguyen et al., 2007).

For the **laboratory experiment**, old females with high oviposition pressure were used. The experiment was stopped after four days to avoid a direct effect of *B. bassiana* on the flies. Thus the observed effects are only due to the repellent effect. Rape oil and Naturalis-L showed a similar efficacy. In this experiment, the flies were supplied with freshly treated fruit of the same stage daily. Therefore, the effects of fruit ripening, i.e. increasing fruit surface and decreasing firmness of fruit, and degradation of the treatment film by sun or rain could not be evaluated in this experiment. **Semi-field experiments** were conducted to clarify these points. In the first semi-field experiment in the Frick orchard, the reduction of efficacy seems mainly attributed to UV-mediated degradation of the products. During the second semi-field experiment, however, the loss of efficacy observed on the third day after treatment might be due to a wash-off of the treatment film by rain. At a concentration of 1%, all oil products showed a similar efficacy in the first experiment. However, in the second experiment the additives of the product Naturalis-L and Telmion showed a lower efficacy. In summary, the effects of the different oil products are too short-lived to provide sufficient control of *R. cerasi* under sunny or rainy conditions. Nevertheless, a **field experiment** using 1% Telmion was conducted. Prior to the first application, fruit samples already showed an infestation rate of 5.8%. This was surprising, because the variety Schauenburger was only at the very beginning of colour change from green to yellow. Moreover, the peak emergence was only seven days past and the pre-oviposition period of *R. cerasi* is considered to last about 10 days (Boller, 1966b). Anyway, with an infestation rate of 42% in the untreated control at harvest, this initial infestation might have only slightly biased the results. Rape oil treatments showed a strong tendency to lower the infestation level. However, differences were not significant, which might have been due to the low sample size (four replicates). The percent infestation (27%) in the rape oil treated trees exceeded the market tolerance (2%) by more than tenfold.

A direct comparison of rape oil, Naturalis-L and the additives of Naturalis-L in one field experiment was not possible due to too small experimental orchards. A comparison of Naturalis-L treatments and treatments with “Additives only” was conducted in the Sissach 3

orchard in 2007 (see part E, Table 13). However, the infestation rate in this experiment was too low to draw any conclusion.

In conclusion, rape oil products seem to degrade too rapidly to provide a good control of fruit infestation. For the product Naturalis-L, these results suggest a dual mode of action: (1) some flies are killed due to fungus infection, resulting in a lower flight activity in the treated trees (see part E), and (2) sub-lethally infected and weakened flies might be overtaxed by the oily film on the fruit surface and therefore unable to oviposit. Although not entirely proven, this hypothesis is supported by two observations: (1) Treatments of Naturalis-L are necessary until shortly before harvest in order to provide an effective control (part E) and (2) although the fungus isolate contained in the product PreFeRal®WG showed a similar efficacy in the laboratory experiments (part A), the field efficacy of PreFeRal®WG (formulated in water dispersible granules instead of oil) was considerably lower (part E). Further research is needed to determine whether the efficacy of the *B. bassiana* product Naturalis-L is partly due to formulating agents.

Part G – Occurrence of the American cherry fruit flies *R. indifferens* & *R. cingulata*

G.1. Introduction

The two American cherry fruit fly species *Rhagoletis indifferens* Curran and *Rhagoletis cingulata* are closely related to the European cherry fruit fly *R. cerasi*. Morphologically the two American species are difficult to separate (Foote, 1981). One individual of this species complex was first observed in Switzerland (canton Ticino) in the 1980s. From 1991 to 1993, there were repeated captures of the American cherry fruit flies in the south of the canton Ticino (Boller & Mani, 1994). Until now, no stable populations of this species group are known in Switzerland (Boller, 2000). However, this may be due to a too low monitoring intensity. A close monitoring in the Rhine Valley (Rheinhessen, Germany) from 2002 to 2004 has revealed that the American cherry fruit fly is widespread and established in many orchards (Lampe et al., 2005; Lampe et al., 2006). The biology of both American species is similar to the European species. The only differences are: the peak flight activity of the American species occurs two weeks later than the peak flight activity of *R. cerasi*, eggs are deposited in yellow fruit, and sour cherries are also attacked.

G.2. *R. cingulata* or *R. indifferens*?

R. cingulata is known as the “Eastern cherry fruit fly“, whereas *R. indifferens* is known as the “Western cherry fruit fly“. Both species are closely related and a morphological or biological discrimination is hardly possible. *R. cingulata* was first described by Loew 1862. In 1932, *R. indifferens* was described as a new species by Curran – a classification which was highly debated during the following years (Simkover, 1953; Frick et al., 1954). It was the work of Bush (1966) that led to the general acceptance of two species. Morphological criteria for determination are given by Bush (1966): *R. indifferens* may be separated from *R. cingulata* by the “presence of black shading on the posterior surface of coxa I. The epandrium is black instead of yellow. [...] Generally, *indifferens* is much more heavily pigmented with black. [...] The thorax is always entirely black.” Male genitalia structure is unsuitable for determination. The wing pattern varies within the species: the apical spot (Figure 28) was observed in 60 to 84% of individuals of *R. cingulata*, but only in 1 to 3% of the individuals of *R. indifferens* (Bush, 1966). According to White & Elson-Harris (1992), the two species are separated mainly according to geographical distribution; for Switzerland the occurrence of *R. indifferens* is mentioned. Information given in current databases is inconsistent: According to the Catalogue of Life (Anonymous, 2007c), *R. cingulata* is a misapplied name for *R. indifferens*. According to ITIS – Integrated taxonomic Information system (Anonymous, 2007b) – both names are valid.

First captures of the American cherry fruit fly in Switzerland were identified as *R. indifferens* by A.L. Norrbom (USDA, Washington D.C.) (Merz, 1991; Mani et al., 1994). Subsequent captures were also identified as *R. cingulata* by A.L. Norrbom (Boller, 2000). The European and Mediterranean Plant Protection Organisation (EPPO) gives the following information on the distribution of the two species: *R. indifferens* is considered to be present in Switzerland, whereas *R. cingulata* was considered to be absent within the EPPO-region until the 1990s (EPPO & CABI, 1996). Until 2003, only a single individual of *R. cingulata* was detected in

Germany (EPPO, 2003). In the Netherlands, however, *R. cingulata* is considered to be present, whereas *R. indifferens* is considered to be absent (EPPO, 2004). In 2006, *R. cingulata* was still present in the Netherlands, whereas it was no longer detectable in Germany (EPPO, 2006).



Figure 28: The American cherry fruit fly *R. cingulata* / *R. indifferens* (left) and the European cherry fruit fly *R. cerasi* (right).

G.3. Monitoring *R. cingulata* / *R. indifferens*

Whenever the flight activity of cherry fruit flies was monitored by yellow sticky traps in field experiments and whenever flies from field collected pupae were used in laboratory experiments, attention was paid to a possible occurrence of *R. cingulata* / *R. indifferens*. Table 15 and Table 16 show numbers of *Rhagoletis* flies monitored in the experiments. Most experiments were conducted in northwestern Switzerland in the cantons Aargau (AG), Baselland (BL) and Zurich (ZH). In addition, a few traps were set up in a private garden in canton Ticino (TI, south Switzerland). During the four experimental years, 45853 *Rhagoletis* flies were captured on yellow sticky traps and 37291 *Rhagoletis* flies were obtained from field collected pupae. In all experiments, only one individual of the American species complex was captured (male, Fructect® trap, Frick orchard, 06 July 2005, Figure 28). It was not possible to determine whether this individual belonged to *R. cingulata* or *R. indifferens*.

Table 15: Monitoring of cherry fruit flies by yellow sticky traps.

Year	Monitoring period	Orchards	Number of traps	Number of captured flies
2004	25 May to 20 July	1 orchard (Aesch, canton BL)	55	12145
	13 May to 10 July	1 orchard (Tegna, canton TI)	4	313
2005	14 May to 15 July	6 orchards (cantons AG, BL)	193	14811
	28 April to 15 July	1 orchard (Tegna, canton TI)	4	1160
2006	10 May to 14 July	6 orchards (canton AG, BL)	194	13573
2007	12 May to 4 July	6 orchards (canton AG, BL)	111	3851

Table 16: Collection of cherry fruit fly pupae for laboratory experiments.

Year	Orchard	Number of collected pupae
2004	20 orchards (canton AG, BL)	12377
2005	14 orchards (canton AG, BL, ZH)	12941
2006	13 orchards (canton AG, BL)	11973

Because there is only a limited production of sour cherries in Switzerland, monitoring was mainly restricted to sweet cherry orchards. In 2007, six traps were installed in sour cherry trees in a mixed (sweet-sour) orchard. These traps captured a total of 1110 flies, none of them belonging to *R. cingulata* / *R. indifferens*. All traps were removed shortly after harvest.

G.4. Conclusions

It can be assumed that the population of *R. cingulata* / *R. indifferens* in northwestern Switzerland is rather small. *R. cingulata* / *R. indifferens* do not cause economic damage to sweet cherry production. However, a monitoring of cherry fruit fly populations until Mid-August on late ripening sour cherries, on wild host plants as well as at higher altitudes is necessary in order to make a general statement on the distribution of *R. cingulata* / *R. indifferens* in Switzerland. According to Boller (2000), *R. cingulata* / *R. indifferens* were often captured at unusually high altitudes (1500 m above sea level).

6. Conclusions

The aim of this thesis was to develop a new control strategy for *R. cerasi* using entomopathogenic fungi.

Laboratory experiments

In a first step, different isolates of entomopathogenic fungi were screened in laboratory experiments (part A). In these experiments, all entomopathogenic fungi tested were found to be pathogenic to *R. cerasi* larvae and adults. These results confirm the susceptibility of Tephritid flies to entomopathogenic fungi reported by different authors (Garcia et al., 1985; Carneiro & Salles, 1994; Castillo et al., 2000; De La Rosa et al., 2002; Dimbi et al., 2003a; Dimbi et al., 2004; Destefano et al., 2005; Ekesi et al., 2005; Konstantopoulou & Mazomenos, 2005; Yee & Lacey, 2005). In addition, these results are the first evidence of the susceptibility of *R. cerasi* to infection with hyphomycetous fungi. Because the flies for the laboratory experiments were collected from different locations in northwestern Switzerland, the susceptibility to entomopathogenic fungi can be generalized for the cherry fruit fly population in the whole region.

Although all tested fungus isolates were pathogenic to adults and larvae, virulence varied considerably among fungus isolates and *R. cerasi* live stages. Larvae showed only a low susceptibility. The infection rates under natural conditions are assumed to be close to zero. Adult flies were found to be highly susceptible to all fungus isolates (*Metarhizium anisopliae* 714, *M. anisopliae* 786, *Isaria fumosorosea* 531, *I. fumosorosea* Apopka 97 and *Beauveria bassiana* ATCC 74040) except *Isaria farinosa* 954. A high mortality during the pre-oviposition period led to reduced oviposition. Thus biological control of *R. cerasi* within the pre-oviposition period of about 10 days (Böhm, 1949) seems possible. Only minor differences were observed between the different fungus isolates: At low concentrations, *Beauveria bassiana* ATCC 74040 tended to be the most virulent.

Field application strategies

L₃ larvae, pupae, and adults are the only life stages which can come in contact with entomopathogenic fungi. Eggs and younger larvae develop inside the fruit and are well protected from any environmental impact. Because natural mortality of pupae during diapause is usually high (Boller, 1966b) and because fungi were shown to have only low efficacy on L₃ larvae and pupae of Tephritid flies (De La Rosa et al., 2002; Ekesi et al., 2002), control of *R. cerasi* should focus on adult flies. Therefore, three application strategies targeted on adult flies were assessed in the second step: (1) the use of entomopathogenic fungi in an attract-and-kill strategy as suggested by Dimbi et al. (2003a) for *Ceratitis* sp.; (2) soil treatments with entomopathogenic fungi focused on teneral adults (Yee & Lacey, 2005), (3) and foliar applications of entomopathogenic fungi as mycoinsecticides.

The commercial fungus isolates *B. bassiana* ATCC 74040 (product: Naturalis-L, Intrachem Bio Italia S.p.A.), *I. fumosorosea* Apopka 97 (product: PreFeRal®WG, Biobest Belgium) and *M. anisopliae* (product: Metarhizium Schweizer®, LBU, Switzerland) were chosen for field applications for several reasons: (1) Only minor differences in virulence were observed between the different fungus isolates in the laboratory experiments. (2) The commercial fungus isolates were available in the large quantities necessary for field applications. (3) The

requirements for registration for *R. cerasi* were considered to be less strict for commercially available products than for new fungus isolates. (4) The whole process of developing a ready-to-use product could be omitted.

Traps and baits for attract-and-kill and mass trapping strategies

For the development of an attract-and-kill strategy, highly attractive traps and baits are needed. The efficacy of different traps and baits was therefore evaluated in field experiments (part D). Results, however, were disappointing. Two baited traps per tree (standard tree in semi-intensive management) were used in the experiments. With effective baits, high captures of *R. cerasi* would be expected in the beginning of the flight period and fewer or no captures closer to harvest. This pattern would indicate that flies are captured shortly after emergence and that the population is reduced considerably by traps and baits. However, as no difference in flight activity was observed between the beginning of the flight period and the whole flight period, I hypothesize that it is not possible to attract a large proportion of flies to the traps and baits shortly after emergence. Although some baits significantly increased captures, none of the baits was outstanding. If more than two traps per tree are needed to achieve good efficacy, attract-and-kill as well as mass trapping strategies become economically unreasonable. According to Remund & Boller (1983), one to eight Rebell® traps, depending on the size of tree, are necessary for good efficacy. A costs calculation (Table 17) shows that the use of traps for mass trapping exceeds any economic benefit. In combination with the TMA-card as bait, half as many traps might be enough. However, the use of this bait at the current price is not economical.

In conclusion, none of the baits tested showed economic potential as an effective attract-and-kill system or for mass trapping in commercial production. Nevertheless, mass trapping may still be the only option for controlling *R. cerasi* in home gardens, in which the application of insecticides or mycoinsecticides is often impossible due to the lack of proper application equipment.

Soil treatments using netting and entomopathogenic fungi

Soil treatments can only be effective if the migration of flies between differently treated trees is low. In order to examine the general potential of soil treatments and to understand the dispersal and flight behaviour of *R. cerasi* in orchards, experiments using netting to cover the soil were conducted (part B). These experiments were set up in commercial, organically managed orchards. The netting reduced fruit infestation by 91%. In addition, it was shown that the flies move only very short distances (less than 5 m) within orchards. Convinced by these results and in the absence of other methods for controlling the cherry fruit fly in organic standard tree orchards, some cherry growers started to use netting in 2007. Because the flies can survive for a long time under the netting, it is advisable to bury the edges of the netting completely. This, however, leads to high labour costs (Table 17). Moreover, expensive, fine-mesh netting (0.8 mm mesh width) is considered to be necessary, as previous laboratory examinations showed that young flies after emergence can easily get through nets with mesh widths of 1.3 mm. Nevertheless, this method could be an option for controlling *R. cerasi* in extensively managed standard tree orchards.

Costs for materials and labour could be reduced (Table 17) by using entomopathogenic fungi formulated on barley grains for soil treatment instead of netting. In the laboratory (part A) and

in a semi-field experiment (part C), it was possible to infect emerging flies by soil treatments. The emergence rate was not reduced, however, adult mortality was significantly increased, which in turn led to reduced oviposition. This strategy is very promising for reducing the population level in standard tree orchards, because the meadow under the trees can still be used for fodder production (which is not possible using netting). In addition, the appearance of the landscape is not disturbed by netting and the work peak for application of barley grains is in early spring and not during the busy time in May/June. Until now, neither large scale experiments nor experiments under on-farm conditions using barley grain-formulated entomopathogenic fungi for soil treatment have been conducted. The efficacy of this strategy needs to be verified in different locations and in different years. In the semi-field experiment, *B. bassiana* ATCC 74040 showed slightly better efficacy than *M. anisopliae*. However, *B. bassiana* ATCC 74040 is currently unavailable in barley grain formulation. If the good results of the first experiment can be replicated, commercial production of *B. bassiana* ATCC 74040 on barley grains needs to be initiated.

For the semi-field experiment, high application rates of barley grains (1000 kg ha⁻¹) were chosen. This rate has to be reduced in order to be economically feasible. For controlling other pests such as *Melolontha melolontha* (Coleoptera: Scarabaeidae), 100 kg ha⁻¹ are recommended. Further research is needed to adjust the dosage. Moreover, the possibility of a long-term establishment of entomopathogenic fungi in the orchard habitat should be examined. Enkerli et al. (2004) showed that applied *Beauveria brongniartii* isolates were still present at test sites up to 14 years after application.

In conclusion, soil treatments with barley grain-formulated entomopathogenic fungi show promise, but final recommendations would be premature given the current state of knowledge. Additional research is needed.

Foliar application of entomopathogenic fungi

Foliar applications of mycoinsecticides are another method for exposing the flies to entomopathogenic fungi. Two commercial mycoinsecticides, Naturalis-L (*B. bassiana* ATCC 74040) and PreFeRal®WG (*I. fumosorosea* Apopka 97), were tested in five field experiments in two years (part E). PreFeRal®WG was only included in one of the experiments and showed a low efficacy. Naturalis-L applied at seven day intervals reduced fruit infestation by 70%. In the experiments, the level of market tolerance could not be achieved by Naturalis-L treatments in orchards with a high infestation level. However, with well-timed applications of Naturalis-L in succeeding years and by applying other phytosanitary measures, e.g. early and complete harvest, removal of infested cherries, it should be possible to lower the population level below the economic threshold.

Based on the laboratory findings, application dates were focused on young flies during the pre-oviposition period. The first application was made within five days after the beginning of the flight period. Four or five treatments were applied in seven day intervals until 14 to seven days before harvest. The period until harvest was considered to be of minor importance, as flies should have been killed before. However, field results proved this hypothesis to be false: a significant negative correlation between the time period until harvest and the infestation level was observed. In addition, captures on yellow sticky traps were only slightly affected by Naturalis-L treatments, indicating that some, but far from all flies were killed by fungus infestation. These observations suggest that there might be a second mode of action of

Naturalis-L. Indeed, additional experiments succeeded in showing that oil products applied on the fruit surface create a mechanical barrier (part F), which hinders the females in drilling a hole and ovipositing in the cherry. Because the Naturalis-L formulation contains oil as an additive, a dual mode of action is hypothesized: (1) some flies are killed due to fungus infection and (2) sub-lethally infested and weakened flies might be overtaxed by the oily film on the fruit surface and therefore unable to oviposit.

In conclusion, the application of Naturalis-L is a suitable and economically reasonable strategy (Table 17) for controlling *R. cerasi*. However, this strategy is not applicable to standard trees taller than eight metres due to possibly insufficient coverage of fruits in the upper canopy. For good efficacy, four treatments of 0.25% Naturalis-L (5×10^4 CFU ml⁻¹) with 1000 l water per hectare should be applied at seven to ten day intervals. The first application should be made five to ten days after the beginning of the flight period. The time period between the last application and harvest should not exceed seven days. Other phytosanitary measures (early and complete harvest; removal of infested cherries) can further enhance the efficacy of Naturalis-L treatments.

Natural occurrence and safety of entomopathogenic fungi

Entomopathogenic fungi are generally considered as soil inhabitants, although conidia can be found on the phylloplanes of hedgerows at 1.5 m above soil level (Meyling & Eilenberg, 2006). Ulevicus et al. (2004) detected conidia of *Beauveria sp.* and *Isaria sp.* from air samples in Lithuania. Marjanska-Cichon et al. (2005) isolated *B. bassiana* and *I. fumosorosea* from orchard soils. Meyling & Eilenberg (2006) suggest that the *B. bassiana* inoculum is present on phylloplanes throughout the growing season in Denmark; however, inoculum density on phylloplanes of hedgerows was lower in May than in September. These observations show that fungal propagules are present in the habitat, however, the natural fungus activity on phylloplanes during the crucial period (May/June) is considered to be very low. Repeated applications of mycoinsecticides might fill this gap.

According to Cook et al. (1996), potential adverse effects of micro-organisms are: (1) the competitive displacement of other micro-organisms, (2) allergenic potential to humans or animals, (3) toxicity of metabolites and (4) pathogenicity to non-target insects. The risk of side effects is considered to be low for foliar applications of Naturalis-L, as fungal propagules are only active for a few days after application. In addition, the oil-based formulation of Naturalis-L makes inhalation of *B. bassiana* conidia nearly impossible, which greatly reduces the possibility of allergic reactions to conidia. Additional information on methods used to assess side effects of biocontrol agents (Babendreier et al., 2005), on side effects of *B. bassiana* on soil arthropods (Parker et al., 1997; Huber et al., 2004), on side effects of entomopathogenic fungi on beneficial arthropods (Flexner et al., 1986; James et al., 1995; Roy & Pell, 2000), as well as on metabolites produced by entomopathogenic fungi (Strasser et al., 2000) are given in the literature. In their literature review, Goettel et al. (2001) concluded that: "history has already demonstrated that fungi can be effectively and safely used in biological control" and, that "hazards must also be weighed in consideration of the benefits of microbials, which to date almost always outweigh those of chemical pesticides."

Integration of mycoinsecticides in pest management programmes

The impact of pesticides on entomopathogenic fungi in the soil is considered to be small (Mochi et al., 2005). Mietkiewski et al. (1997) found that pesticides used under field conditions are unlikely either to kill the entomopathogenic fungi present in the treated area or to limit their recolonization. However, fungal propagules are much more exposed to pesticides when applied to phylloplanes. Therefore, close attention has to be paid to the whole pest management programme. The use of fungicides particularly can interfere with entomopathogenic fungi. In Swiss organic cherry production, only sulphur and neem oil are likely to be applied during the critical period. Fortunately, both pesticides were found to be compatible with entomopathogenic fungi (Tamai et al., 2002; Depieri et al., 2005; Luke & Bateman, 2006). However, many of the synthetic fungicides used in integrated pest management strategies were found to be highly toxic to *B. bassiana* (Jaros-Su et al., 1999; Cavalcanti et al., 2002) and *I. fumosorosea* (Er & Gökçe, 2004). Among 36 fungicides tested, only three were compatible with *B. bassiana*, whereas insecticides were less toxic: 24 out of 54 tested insecticides interfered with fungus development (Tamai et al., 2002). In some cases, differences were found among products containing the same active ingredient (Dimethoate) in different formulations. Thus, the integration of mycoinsecticides for cherry fruit fly control in an organic plant protection system seems possible; including mycoinsecticides into integrated pest management programmes might, however, be challenging.

R. indifferens* and *R. cingulata

It is known that the two American cherry fruit fly species *R. indifferens* and *R. cingulata* were introduced in Europe in the 1980s (Mani et al., 1994). The isolates of entomopathogenic fungi selected for *R. cerasi* may exhibit a different virulence towards these species. However, the pathogenicity and virulence of fungus isolates could not be tested against these species because it was not possible to collect enough individuals for laboratory experiments. It is thus not certain, whether mixed populations of American and European cherry fruit flies might lead to a reduced efficacy of the treatments. Therefore, it is crucial to know the densities of the American species in commercial cherry orchards. The results of a four-year monitoring campaign (part G) indicate that the population density of the American species is very low in commercial sweet cherry orchards in northwestern Switzerland. The entomopathogenic fungi should therefore work as expected in this region. In other cherry growing areas with high infestation levels caused by *R. indifferens* or *R. cingulata* (Rhine Valley, Germany) (Lampe et al., 2006), close attention needs to be paid to this possible gap in efficacy. However, because Naturalis-L is effective on other Tephritid species (such as *B. oleae* and *C. capitata*) in Italy, a certain degree of efficacy of Naturalis-L or soil treatments with entomopathogenic fungi can also be expected for the American cherry fruit fly species.

Other possibilities for controlling *R. cerasi*

One application of Dimethoate has been the standard for controlling *R. cerasi* in Swiss sweet cherry production since the 1960s. First attempts to reduce the application of chemical insecticides were made in the 1970s (Boller et al., 1980). However, Dimethoate is still widely used because it is by far the most cost-efficient method for controlling *R. cerasi* (Table 17). In Germany, however, this active ingredient is no longer registered for use in fruit production because of problems of ecotoxicity and residues on harvested cherries. In addition,

Dimethoate is not allowed in organic agriculture. The application of alternative insecticides compatible with organic agricultural standards was evaluated at the Research Institute of Organic Agriculture (FiBL, Switzerland) from 1996 to 2002. None of the insecticides tested (neem oil, quassia, spinosad, pyrethrin) significantly reduced infestation levels in fruit.

With the increasing number of dwarf tree orchards shielded from rain to prevent the large sized cherry varieties (>24 mm fruit diameter) from splitting, crop netting has become a possible method of cherry fruit fly control (Häseli et al., 2005). Experiments using netting to cover the trees were conducted at the Palatinate Agricultural Service Centre (DLR Rheinpfalz, Germany (Balmer, 2005)), at the Bavarian State Research Centre for Agriculture (LfL Bayern, Germany (Geipel, 2002)) and at the Research Institute of Organic Agriculture (FiBL, Switzerland, Häseli, personal communication). All experiments showed that crop netting is a viable, cost-efficient strategy (Table 17) for protecting cherries from infestation. The “Rantai K” net-type with a mesh size of 1.3 mm was used in all experiments. In my laboratory experiments with small cages, some cherry fruit flies (males and young, small females) were able to pass through these nets. However, under field conditions the passage of cherry fruit flies through a net with 1.3 mm mesh size is considered to be unlikely, as it is mostly mature females that migrate to new habitats driven by high oviposition pressure (Katsoyannos, 1979). Orientation of cherry fruit flies during dispersal flight is considered to be based mainly on visual cues, such as shrub or tree-like silhouettes (Katsoyannos et al., 1986). Whether a hail net with a mesh size much bigger than the body size of cherry fruit flies could prevent an immigration of flies into the orchard just by blocking the trees from view, has not yet been tested in meaningful experiments. Experiences of Swiss cherry growers, however, show that orchards covered with hail nets have remained free from infestation for many years. The use of hail nets would be less expensive than the use of insect nets. Based on the current knowledge, however, the fine-mesh insect net should be used for cherry fruit fly control. Netting should be installed before the beginning of the flight period and the netting should remain in place until the latest ripening cherry varieties are harvested.

Costs of different strategies for controlling *R. cerasi* are given in Table 17. The application of Dimethoate is by far the cheapest solution for cherry fruit fly control. However, the higher prices obtained for organically grown cherries might justify the higher input for pest control. The Arbokost 2007 program ((Anonymous, 2007a), see Table 17) assumes a yield of 14.4 kg of cherries per tree (Kordia variety) in conventional cherry orchards. With 800 trees per hectare, 11500 kg cherries per hectare can be harvested. In experiments conducted at the Research Institute of Organic Agriculture (FiBL, Switzerland; Häseli, personal communication), it was shown that a similar yield can be obtained in organic production systems. Grower prices in Switzerland depend on the diameter of the fruit and on the production system. Details are given in Table 18. The revenue per hectare in organic production is 15000 € higher than in conventional production. This would cover the additional costs for cherry fruit fly control.

Table 17: Costs per hectare of different cherry fruit fly control methods.

	Intensively managed dwarf-tree orchard	Standard trees in semi-intensive systems	Extensively managed standard trees
Trees per ha	800 trees per ha	200 to 500 trees per ha (350 trees per ha)	50 to 80 trees per ha (65 trees per ha)
Tree size	height of first branches: 0.5 m, tree height: 3.5 m, canopy diameter: 3 to 4 m (7 to 12 m ²)	height of first branches: 1.2 m, tree height: 5 to 6 m, canopy diameter: 5 to 7 m (20 to 40 m ²)	height of first branches: 1.8 m, tree height: 8 to 10 m, canopy diameter: 11 to 13 m (100 to 130 m ²)
Dimethoate treatment ¹	400 l ha ⁻¹ with 0.8 l Perfekthion®, one application: materials: 24.20 € + machines: 50.50 € + labour: 13.42 € = 88.12 €	400 l ha ⁻¹ with 0.8 l Perfekthion®, one application: materials: 24.20 € + machines: 50.50 € + labour: 13.42 € = 88.12 €	400 l ha ⁻¹ with 0.8 l Perfekthion®, one application: materials: 24.20 € + machines: 50.50 € + labour: 13.42 € = 88.12 €
Mass trapping with yellow sticky traps ²	One Rebell® trap per tree: materials: 1812.5 € + labour: 134.19 € = 1946.69 €	Five Rebell® traps per tree: materials: 3964.84 € + labour: 1761.21 € = 5726.05 €	12 Rebell® traps per tree: materials: 1767.19 € + labour: 785.00 € = 2552.18 €
Mass trapping with baited yellow sticky traps ³	0.5 Rebell® traps per tree with 0.5 TMA-cards: materials: 2156.25 € + labour: 89.64 € = 2245.89 €	Three Rebell® traps per tree with three TMA-cards: materials: 5660.17 € + labour: 1115.90 € = 6776.06 €	Seven Rebell® traps per tree with seven TMA-cards: materials: 2452.73 € + labour: 483.56 € = 2936.29 €
Soil covering with netting ⁴	materials: 930.75 € + labour: 1610.25 € = 2541.00 €	materials: 930.75 € + labour: 1610.25 € = 2541.00 €	materials: 930.75 € + labour: 1610.25 € = 2541.00 €
Soil treatment with barley grain-formulated fungi ⁵	100 kg ha ⁻¹ Metarhizium Schweizer® : materials: 200 € + machines: 312.5 € + labour: 201.28 € = 713.78 €	100 kg ha ⁻¹ Metarhizium Schweizer® : materials: 200 € + machines: 312.5 € + labour: 201.28 € = 713.78 €	100 kg ha ⁻¹ Metarhizium Schweizer®: materials: 200 € + machines: 312.5 € + labour: 201.28 € = 713.78 €
Application of Naturalis-L ⁶	800 l ha ⁻¹ with 2 l Naturalis-L, four applications: materials: 515.00 € + machines: 202.00 € + labour: 53.68 € = 770.68 €	1000 l ha ⁻¹ with 2.5 l Naturalis-L, four applications: materials 643.75 € + machines: 202.00 € + labour: 53.68 € = 899.43 €	Not possible because of insufficient coverage in the upper parts of the canopy.
Crop netting ⁷	materials: 242.37 € + labour: 268.38 € = 510.75 €	Not possible.	Not possible.

Only results of one year in a small-plot, semi-field experiment! Further research is needed to evaluate efficacy!

Table 17: Explanatory notes

Standard costs were calculated according to Arbokost 2007 (Anonymous, 2007a), a business management simulation program based on data evaluated in Switzerland. This program is provided by the Federal Research Station agroscope ACW Wädenswil and uses the following values: labour costs 13.42 € per hour; machine costs for pesticide application: 50.50 € per ha and application; time for installation and removal of crop netting 20 hours per ha. For investments: discount rate: 3.5%, amendment factor for discounting 0.6; Costs were calculated using Swiss prices for products. Currency was converted assuming an exchange rate of 1 € = 1.60 CHF.

- 1.) Perfekthion® (Dimethoate): 30.25 € per litre (Leu Gygax AG, Switzerland), 0.8 l ha⁻¹, one application. One hour per application per hectare for machine and labour costs.
- 2.) Rebell® amarillo: 2.27 € per trap (Andermatt Biocontrol AG, Switzerland). Labour input for installation and removal: 45 s per trap (dwarf trees), 4.5 min per trap (in standard tree orchards; estimation made by cherry growers). The traps can be cleaned and re-used: labour input 1 h for 10 traps, material input 9.00 € per 10 traps: 22.42 € per 10 traps = 2.24 € per trap (more or less the same price as new traps).
- 3.) TMA-card: 3.13 € per card (Andermatt Biocontrol AG, Switzerland). Additional time needed to attach the bait to the trap: 15 s per trap.
- 4.) Biocontrol Net 0.8: 0.85 € m⁻² (Andermatt Biocontrol AG, Switzerland). Because it is not necessary to cover the whole surface, the area covered per ha is reduced to 0.75 ha. Costs for net: 6375 € Costs per year (8 years): 930.75 € Labour input: 120 h (estimated from time needed to set up my experiments).
- 5.) Metarhizium Schweizer ®: 20 € per 10 kg (LBU, Switzerland). 100 kg ha⁻¹. Machine costs for lawn aerator: 31.25 € per hour (10 hours). Total labour input: 15 h (time estimated according to field experiences by LBU, Switzerland). Because it is not necessary to treat the whole surface, but only the soil immediately under the branches, the treated area over which the 100 kg are distributed is reduced to 0.5 to 0.75 ha.
- 6.) Naturalis-L: 64.38 € per litre (Andermatt Biocontrol AG, Switzerland), 2 - 2.5 l ha⁻¹, four applications. One hour per application per hectare for machine and labour costs.
- 7.) Rantai K: 0.77 € m² (Hortima AG, Switzerland). Costs for net: 1291.50 € Costs per year (6 years): 242.37 €. Assuming that a plastic cover to shelter the fruits against rain is already installed: time for installation and removal of netting: 20 h. Size of net and time needed was calculated according to Balmer (2005) and Balmer (personal communication).

Table 18: Prices for organic and conventional cherries in Switzerland 2007 (*according to Arbokost 2007).

Category	Fruit size (diameter)*	% of total yield*	Grower price for conventional cherries*	Grower price for organic cherries
Class I	21-23 mm	5%	2.31 € per kg	3.75 € per kg
Class Extra	24-25 mm	60%	3.25 € per kg	4.69 € per kg
Class Premium	26-28 m	30%	5.63 € per kg	4.38 € per kg
Income per ha			38848.44 € per ha	53906.25 € per ha

7. Recommendations of insecticide-free strategies for controlling *R. cerasi*

Well-managed orchards are a prerequisite for the effective control of *R. cerasi*:

- Trees should be regularly pruned and trees height should be limited to 10 m to allow good coverage of Naturalis-L and to facilitate an early and complete harvest of fruit.
- For new plantings of extensively managed standard trees, varieties suitable for mechanical harvest should be chosen to enable a quick harvest. Harvesting the cherries early and completely reduces the population level of *R. cerasi* by removing the larvae from the orchards before pupation.
- Infested fruits should not be dropped on the ground.
- If possible, early ripening cherry varieties should be chosen, because they are harvested before the majority of the flies are ready to oviposit.
- It is recommended not to cut the grass under the tree canopies until shortly before harvest. With a higher plant cover the soil temperatures remain low, which can delay fly emergence for about ten days (Müller, 1970).
- *Lonicera* sp. shrubs and neglected cherry trees in the close vicinity (200 to 500 m) of orchards should be removed in order to reduce the immigration of flies.

Knowledge of first fly appearance is important for a proper timing of control measures. Depots of pupae in the soil can be used for precise monitoring of emergence (Russ et al., 1973). Flight period and flight activity of *R. cerasi* can also be monitored using yellow sticky traps (Rebell® amarillo). In mid-May prior to fly emergence, one or two traps per cherry variety should be placed on the southeast side of the tree canopy in full sun and should be examined twice a week. However, traps are not good indicators of the infestation level (Fimiani, 1989). Depending on yield, weather conditions and trap position, the economic threshold ranges between two and ten flies per trap. Treatment decisions should therefore be based on the infestation level in the previous year. The infestation level can be estimated using the salt solution test (Schneider, 1947): 100 randomly picked cherries of each cherry variety are crushed until the pits are separated from the pulp. A saturated salt solution (350 g salt per litre water) is added. Floating larvae can be counted after 10 minutes.

Based on economic considerations, the following strategies for cherry fruit fly control are recommended.

- Crop netting with fine-mesh insect net (1.3 mm) to avoid immigration of flies into the orchard is considered to be the most effective and most economic strategy in intensively managed dwarf tree orchards covered by plastic or hail net.
- In intensively managed dwarf tree orchards without plastic cover or hail net as well as in semi-intensively managed standard tree orchards, foliar applications of Naturalis-L (*B.*

bassiana) are most suitable. Currently, Naturalis-L is registered for cherry fruit fly control in Italy and Switzerland. Registration in the Netherlands and in Germany is pending.

- In extensively managed standard trees, *R. cerasi* management is still difficult and expensive. Most of these trees are used to produce cherries for the distillery industry and are not suited to mechanical harvest. Therefore, fruit are usually harvested late, which allows the larvae to pupate in the soil leading to high infestation pressure in the following year. In addition, the grass under the trees is often used for hay or green fodder production. The use of netting to cover the soil is therefore not always practicable. Mass trapping with traps and baits is expensive, and there are considerable side effects on non-target insects. In addition, cherry growers usually use too few traps per tree, resulting in poor efficacy. Further research is needed to evaluate whether soil treatments with barley grain formulated fungi could be a viable strategy for controlling *R. cerasi* in extensively managed standard trees.

8. Register of figures and tables

Figures

Figure 1: The European cherry fruit fly: newly emerged female with ptilinum (left), female (middle) and male (right).	14
Figure 2: Mating of <i>R. cerasi</i> .	15
Figure 3: Infested cherries.	19
Figure 4: Damaged cherries with exit holes of larvae.	19
Figure 5: Pupae of <i>R. cerasi</i> .	20
Figure 6: Cumulative mortality of adult <i>R. cerasi</i> after treatment with different fungus isolates.	33
Figure 7: Effects of different fungus treatments on mortality (\pm se) of adult <i>R. cerasi</i> (collection site: Arlesheim BL, Switzerland) and on fecundity (number of eggs \pm se). Statistical analysis for mortality: Data transformed [arcsine \sqrt{x}]; one-way ANOVA: Day 5: $F_{5,24}=17.29$, $p<0.001$; Day 30: $F_{5,24}=21.38$, $p<0.001$; Tukey HSD-Test $\alpha=0.05$; Statistical analysis for number of eggs: One-way ANOVA: $F_{5,24}=13.97$, $p<0.001$; Tukey HSD-Test $\alpha=0.05$, different letters show significant differences.	34
Figure 8: Mycosis of flies placed on moist peat A: Female <i>R. cerasi</i> treated with Ma 714, three days after death; B: Male <i>R. cerasi</i> treated with Ma 714, five days after death; C: Female <i>R. cerasi</i> treated with Ma 786, three days after death; D: Male <i>R. cerasi</i> treated with Ma 786, six days after death; E: Female <i>R. cerasi</i> treated with Ifr 531, two days after death; F: Female <i>R. cerasi</i> treated with Ifr 531, six days after death; G: Female <i>R. cerasi</i> treated with Ifr 97, one day after death; H: Female <i>R. cerasi</i> treated with Ifr 97, two days after death; I: Male <i>R. cerasi</i> treated with Bb 74040, one day after death; J: Female <i>R. cerasi</i> treated with Bb 74040, five days after death.	34
Figure 9: Effects of different fungus treatments on mortality (\pm se) of adult <i>R. cerasi</i> (collection site: Eptingen BL, Switzerland) and on fecundity (number of eggs \pm se). Statistical analysis for mortality: Data transformed [arcsine \sqrt{x}]; one-way ANOVA: Day 5: $F_{5,24}=3.11$, $p=0.03$; Day 30: $F_{5,24}=12.76$, $p<0.001$; Tukey HSD-Test $\alpha=0.05$; Statistical analysis for number of eggs: Data transformed [$\sqrt{x+1}$]; one-way ANOVA: $F_{5,24}=0.70$, $p=0.63$; different letters show significant differences.	35
Figure 10: Cumulative mortality of adult <i>R. cerasi</i> after treatment with different fungus isolates at three concentration levels.	36
Figure 11: Effects of different fungus treatments on mortality (\pm se) of adult <i>R. cerasi</i> (collection site: Hottwil AG, Switzerland) and on fecundity (number of eggs \pm se). Statistical analysis for mortality: Data transformed [arcsine \sqrt{x}]; one-way ANOVA: Day 5: $F_{12,52}=14.49$, $p<0.001$; Day 30: $F_{12,52}=32.97$, $p<0.001$; Tukey HSD-Test $\alpha=0.05$; Statistical analysis for number of eggs: Data transformed [$\sqrt{x+1}$]; one-way ANOVA: $F_{12,52}=21.06$, $p<0.001$; Tukey HSD-Test $\alpha=0.05$, different letters show significant differences.	37
Figure 12: Effects of different fungus treatments on mortality (\pm se) of three age-groups of adult <i>R. cerasi</i> (collection sites: Hottwil AG and Sissach BL, Switzerland). Statistical analysis for mortality: Data transformed [arcsine \sqrt{x}]; two-way ANOVA: Day 5: fungus isolate: $F_{4,60}=56.46$, $p<0.001$; age-groups: $F_{2,60}=12.27$, $p<0.001$; isolate*age: $F_{8,60}=2.42$, $p=0.02$; Day 30: fungus isolate: $F_{4,60}=56.49$, $p<0.001$; age-groups: $F_{2,60}=26.37$, $p<0.001$; isolate*age: $F_{8,60}=2.488$, $p=0.009$; Tukey HSD-Test $\alpha=0.05$; different letters show significant differences. Statistical analysis for number of eggs: Data transformed [$\sqrt{x+1}$]; two-way ANOVA: fungus isolate: $F_{4,60}=53.67$, $p<0.001$; age-groups: $F_{2,60}=13.42$, $p<0.001$; isolate*age: $F_{8,60}=2.15$, $p=0.04$; Tukey HSD-Test $\alpha=0.05$, different letters show significant differences.	38
Figure 13: Effects of soil treatments with different fungus isolates on mortality (\pm se) of emerged adult <i>R. cerasi</i> (collection site: Hottwil AG, Switzerland). Pooled data over the two moisture levels. Statistical analysis for mortality: Data transformed [arcsine \sqrt{x}]; two-way ANOVA: Fungus isolate: $F_{4,54}=64.49$, $p<0.001$; Tukey HSD-Test $\alpha=0.05$; Statistical analysis for number of eggs per female: two-way ANOVA: Fungus isolate: $F_{4,54}=21.54$, $p<0.001$; Tukey HSD-Test $\alpha=0.05$; different letters show significant differences.	40
Figure 14: Installation of the soil covering netting in the Sissach 1 orchard on 18 May 2005.	47
Figure 15: Experimental trees (Möhlin 2 orchard).	48
Figure 16: Effects of soil covering with netting on average number of <i>R. cerasi</i> (\pm se) on yellow sticky traps in the Sissach 1 orchard (2005) and the Möhlin 1 orchard (2006). Statistical analysis for the Sissach 1 orchard: one-way ANOVA: total captures: $F_{2,12}=34.99$, $p<0.001$; early captures: $F_{2,12}=11.50$, $p=0.001$; Statistical analysis for the Möhlin 1 orchard: two-way ANOVA [treatment, cherry variety]: total captures: treatment: $F_{2,9}=118.46$, $p<0.001$, variety: $F_{4,9}=4.70$, $p=0.03$; early captures: treatment: $F_{2,9}=40.10$, $p<0.001$, variety: $F_{4,9}=3.21$, $p=0.07$; Tukey HSD-Test $\alpha=0.05$; different letters show significant differences.	49
Figure 17: Effects of soil covering with netting on percentage infestation rate of cherries with <i>R. cerasi</i> larvae (\pm se) in the Möhlin 1 orchard (2006). Statistical analysis: two-way ANOVA [treatment, cherry variety]: treatment: $F_{2,9}=6.61$, $p=0.02$, variety: $F_{4,9}=1.36$, $p=0.32$; Tukey HSD-Test $\alpha=0.05$; different letters show significant differences.	50
Figure 18: Flight activity of <i>R. cerasi</i> in the Sissach 1 orchard in 2005.	51

Figure 19: Flight activity of <i>R. cerasi</i> in the Möhlin 1 orchard in 2006.....	51
Figure 20: Flight activity of <i>R. cerasi</i> in the Möhlin 2 orchard in 2005.....	51
Figure 21: Effects of soil treatments with <i>B. bassiana</i> and <i>M. anisopliae</i> formulated on barley grains on mortality (\pm se) of emerging adult <i>R. cerasi</i> and on number of eggs (\pm se) per female (Statistical analysis for mortality: Data transformed [$\arcsin\sqrt{x}$], two-way ANOVA; treatment: $F_{2,14}=13.07$, $p<0.001$; origin of fly pupae: $F_{1,14}=0.42$, $p=0.53$; statistical analysis for number of eggs per female: two-way ANOVA: treatment: $F_{2,13}=9.84$, $p=0.003$; origin of pupae: $F_{1,13}=1.12$, $p=0.31$; Tukey HSD-Test $\alpha=0.05$; different letters show significant differences).....	58
Figure 22: Photo-electors used to monitor fly emergence in Aesch 2004 (left) and in Eptingen 2006 (right).....	68
Figure 23: Fly emergence per 5 m ² monitored with photo-electors and flight period monitored with Rebell® traps in the Aesch orchard in 2004.	71
Figure 24: Fly emergence per 5 m ² monitored by photo-electors and flight period monitored with Rebell® traps in the Eptingen orchard in 2006.	78
Figure 25: Oviposition deterring effect of Naturalis-L, sterile Naturalis-L and rape oil (Telmion) in the laboratory experiment: Number of eggs per day (\pm se) in differently treated cherries.....	102
Figure 26: Oviposition deterring effect of oil products in the first semi-field experiment: Number of eggs per day (\pm se) in differently treated cherries, fruit samples taken immediately (0d), three, six, and nine days after treatment.....	103
Figure 27: Oviposition deterring effect of oil products in the second semi-field experiment: Number of eggs per day (\pm se) in differently treated cherries, fruit samples taken immediately (0d), three, and six days after treatment.....	103
Figure 28: The American cherry fruit fly <i>R. cingulata</i> / <i>R. indifferens</i> (left) and the European cherry fruit fly <i>R. cerasi</i> (right).....	107

Tables

Table 1: Source of fungus isolates used in laboratory experiments; all field collected isolates were obtained from Agroscope Research Station ART Reckenholz, Zurich.....	28
Table 2: Effects of different fungus treatments on survival of <i>R. cerasi</i> larvae (collection site Aesch BL, Switzerland).....	41
Table 3: Results of soil treatments with Naturalis-L, PreFeRal®WG and conidia suspensions of <i>M. anisopliae</i>	57
Table 4: Traps and baits used in the experiments. (x* "Agar"-bait not in bottle, but shrink-wrapped in plastic).....	66
Table 5: Results of experiments in the Aesch orchard in 2004.....	72
Table 6: Results of experiments in the Aesch orchard in 2005.....	74
Table 7: Results of experiments in the Aesch orchard in 2006.....	75
Table 8: Results of the 2005 experiment in the Frick orchard.	77
Table 9: Results of the 2005 experiment in the Möhlin 1 orchard.....	77
Table 10: Results of the 2005 experiment in the Sissach 5 orchard.....	77
Table 11: Results of the 2006 experiment in the Eptingen orchard.	79
Table 12: Monitoring period, application and sampling dates and sample size in the 2006 and 2007 experiments.	89
Table 13: Summarized results of field application experiments with mycopesticide.....	92
Table 14: Number of CFU g ⁻¹ leaves (\pm se) and percent CFU compared to the first sampling date in the Sissach 2 and 4 orchards in 2006 and in the Frick orchard in 2007.....	94
Table 15: Monitoring of cherry fruit flies by yellow sticky traps.	107
Table 16: Collection of cherry fruit fly pupae for laboratory experiments.....	108
Table 17: Costs per hectare of different cherry fruit fly control methods.....	116
Table 18: Prices for organic and conventional cherries in Switzerland 2007 (*according to Arbokost 2007).....	117

9. Acknowledgements

First of all, I want to thank Prof. Dieter Treutter (Technische Universität München, Germany) and Dr. Eric Wyss (Research Institute of Organic Agriculture, FiBL, Frick, Switzerland) for giving me the opportunity to work on this subject and for giving me free rein regarding most decisions.

Thanks are also due to my colleagues at the Research Institute of Organic Agriculture (FiBL, Frick, Switzerland), especially to Thomas Amsler, Dr. Jose Granado, Andreas Häseli, Nicole Mahlberg, Bruno Nietlispach, Hans-Jakob Schärer and Dr. Franco Weibel (alphabetical order), and to our trainees: Céline Géneau, Phillip Holzherr and Antonia Schneider for help during the field experiments and for advice concerning laboratory methods.

I am also grateful to the staff of the Swiss Federal Research Stations Agroscope ART Reckenholz and Agroscope ACW Wädenswil: Dr. Ernst Boller, Dr. Jürg Grunder, Hansueli Höpli, Dr. Stefan Kuske, Christina Pilz, and Dr. Jörg Samietz for technical discussions. In particular, I thank Dr. Siegfried Keller (Agroscope ART) for providing field collected fungus isolates for my laboratory experiments.

Many thanks to Andermatt Biocontrol AG (Switzerland) for providing Rebell® traps, soil cover netting, PreFeRal® WG, and most of the commercial baits. I wish to thank Intrachem Bio Italia S.p.A. for providing the Naturalis-L product and LBU (Switzerland) for providing barley grain formulated *M. anisopliae* (Metarhizium Schweizer ®).

For helpful discussions on statistical problems, I am grateful to Dr. Patsy Haccou (Leiden University, Netherlands), Prof. Ian C.W. Hardy (Nottingham University, UK), Dr. Lia Hemerik (Wageningen University, Netherlands), Prof. Thomas S. Hoffmeister (Bremen University, Germany) and Dr. Eric Wajnberg (INRA, France). Especially important in this respect was the statistical course at the BEPAR Summer School (Bremen University, 20 to 25 August 2007), which I was fortunate to attend.

I gratefully acknowledge the financial support of the Gerling Foundation (Switzerland) and of the Landwirtschaftliches Zentrum Ebenrain (LZE, Sissach, Switzerland). In this respect I wish to express my gratitude to Werner Mahrer and Dr. Andi Buser (LZE, Sissach, Switzerland).

Finally, I would like to thank the cherry growers for providing the wonderful, maggot-ridden cherries and for permitting the experiments to be conducted in their orchards.

10. References

- ABBOTT, W. S. (1925). A method for computing the effectiveness of an insecticide. -- *Journal of Economic Entomology* 18, 265-267.
- AGEE, H. R., BOLLER, E., REMUND, U., DAVIS, J. C. & CHAMBERS, D. L. (1982). Spectral sensitivities and visual attractant studies on the Mediterranean Fruit Fly, *Ceratitis capitata* (Wiedemann), Olive Fly, *Dacus oleae* (Gmelin), and the European Cherry Fruit Fly, *Rhagoletis cerasi* (L) (Diptera, Tephritidae). -- *Journal of Applied Entomology* 93, 403-412.
- AHMAD, M. & CARL, K. (1966). The natural enemies of *Rhagoletis* in Europe. -- Internal Report: Commonwealth Institute of Biological Control, Delemont, p. 10.
- ALBEROLA, T. M., APTOSOGLOU, S., ARSENAKIS, M., BEL, Y., DELRIO, G., ELLAR, D. J., FERRE, J., GRANERO, F., GUTTMANN, D. M., KOLIAIS, S., MARTINEZ-SEBASTIAN, M. J., PROTA, R., RUBINO, S., SATTA, A., SCARPELLINI, G., SIVROPOULOU, A. & VASARA, E. (1999). Insecticidal activity of strains of *Bacillus thuringiensis* on larvae and adults of *Bactrocera oleae* Gmelin (Dipt. Tephritidae). -- *Journal of Invertebrate Pathology* 74, 127-136.
- ALUJA, M. & BOLLER, E. F. (1992). Host marking pheromone of *Rhagoletis cerasi*: field deployment of synthetic pheromone as a novel cherry fruit fly management strategy. -- *Entomologia experimentalis et applicata* 65, 141-147.
- ANAGNOU-VERONIKI, M., KONTODIMAS, D. C., ADAMOPOULOS, A. D., TSIMBOUKIS, N. D. & VOULGAROPOULOU, A. (2005). Effects of two fungal based biopesticides on *Bactrocera (Dacus) oleae* (Gmelin) (Diptera: Tephritidae). -- *IOBC wprs Bulletin* 28, 49-51.
- ANAGNOU-VERONIKI, M., VEYRUNES, C. J., KUHL, G. & BERGOIN, M. (1997). A nonoccluded reovirus of the olive fly, *Dacus oleae*. -- *Journal of General Virology* 78, 259-263.
- Anonymous. (2007a). Arbokost. -- Electronic source: <http://www.acw.admin.ch/themen/00516/01839/01849/index.html?lang=de>.
- Anonymous. (2007b). Integrated taxonomic Information system. -- Electronic source: <http://www.itis.gov>.
- Anonymous. (2007c). Species 2000 ITIS: Catalogue of life: 2007 annual checklist. -- Electronic source: <http://www.catalogueoflife.org/>.
- BABENDREIER, D., BIGLER, F. & KUHLMANN, U. (2005). Methods used to assess non-target effects of invertebrate biological control agents of arthropod pests. -- *BioControl* 50, 821-870.
- BAKER, C. R. B. & MILLER, G. W. (1978). Effect of temperature on postdiapause development of 4 geographical populations of European Cherry Fruit Fly (*Rhagoletis cerasi*). -- *Entomologia experimentalis et applicata* 23, 1-13.
- BALAZS, K. & JENSER, G. (2004). Significance of the parasitoids and predators in IPM of sour-cherry. -- *IOBC wprs Bulletin* 27, 3-7.
- BALMER, M. (2005). Kulturschutznetze zur Kontrolle der Kirschfruchtfliege im überdachten Anbau. -- *Obstbau*, 14-16.
- BARTOLINI, P. & ZOCCHI, R. (1957). Esperienze di lotta contro la *Rhagoletis cerasi* L. nel 1957. -- *Redia* 42, 349-358.
- BASHIRUDDIN, J. B., MARTIN, J. L. & REINGANUM, C. (1988). Queensland fruit fly virus, a probable member of Picornaviridae. -- *Archives of Virology* 100, 61-74.
- BATEMAN, M. A. (1972). The ecology of fruit flies. -- *Annual Review of Entomology* 17, 493-518.
- BERLESE, A. (1906). Probabile methodo di lotta efficace contro la *Ceratitis capitata*, *Rhagoletis cerasi* ed altri Tripetidi. -- *Redia* 3, 386-388.
- BLÜMEL, S., KECK, M., NOWOTNY, N., FIEDLER, W. & RUSS, K. (1991). Nachweis und Therapie von Rickettsia-like organisms (RLO's) in den Ovarien der Europäischen Kirschfruchtfliege (*Rhagoletis cerasi* L.; Trypetidae): ein Beitrag zur Frage der unidirektionalen Kreuzungssterilität dieser Art. -- *Pflanzenschutzberichte* 52, 41-47.
- BLÜMEL, S. & RUSS, K. (1989). Sterile Insect Technique - Manipulation of races. -- In: *Fruit flies their biology, natural enemies and control*. (A. S. Robinson & G. Hooper, eds). Elsevier, Amsterdam, p. 387-389.
- BÖHM, H. (1949). Untersuchungen über die Lebensweise und Bekämpfung der Kirschfliege (*Rhagoletis cerasi* L.). -- *Pflanzenschutzberichte* 3, 177-185.
- BOLLER, E. (1964). Auftreten der Kirschenfliege (*Rhagoletis cerasi* L.) und Prognose mittels Bodentemperaturen im Jahre 1963. -- *Schweizerische Zeitschrift für Obst- und Weinbau* 73, 53-58.
- . (1966a). Beitrag zur Kenntnis der Eiablage und Fertilität der Kirschenfliege *Rhagoletis cerasi* L. -- *Mitteilung der Schweizerischen entomologischen Gesellschaft* 38, 195-202.

- (1966b). Der Einfluss natürlicher Reduktionsverfahren auf die Kirschenfliege *Rhagoletis cerasi* L. in der Nordwestschweiz, unter besonderer Berücksichtigung des Puppenstadiums. -- Schweizerische landwirtschaftliche Forschung 5, 154-210.
- (1966c). Drei Jahre Erfahrung in der Zeitpunktsprognose für die Kirschenfliegenbekämpfung mittels Bodentemperaturen. -- Schweizerische Zeitschrift für Obst- und Weinbau 102, 63-67.
- (1968). An artificial oviposition device for European Cherry Fruit Fly *Rhagoletis cerasi*. -- Journal of Economic Entomology 61, 850-851.
- (1969). Neues über die Kirschenfliege: Freilandversuche im Jahr 1969. -- Schweizerische Zeitschrift für Obst- und Weinbau 105, 566-572.
- (1970). Heutiger Stand der Kirschenfliegenforschung in der Schweiz. -- Schweizerische landwirtschaftliche Forschung 3/4, 307-326.
- (1972). Zum Verkauf und Einsatz neuer Kirschenfliegenfallen im Jahre 1972. -- Schweizerische Zeitschrift für Obst- und Weinbau 108, 84-87.
- (1983). Biotechnical methods for the management of fruit fly populations. -- In: Fruit flies of economic importance (R. Cavalloro, ed). Balkema, Rotterdam, p. 342-352.
- (1989a). Cytoplasmatic incompatibility in *Rhagoletis cerasi*. -- In: Fruit flies their biology, natural enemies and control. (A. S. Robinson & G. Hooper, eds). Elsevier, Amsterdam, p. 69-74.
- (2000). Situationsbericht über nordamerikanische Fruchtfliegenarten in der Schweiz (Diptera: Tephritidae). -- Internal Report: Eidgenössische Forschungsanstalt für Obst-, Wein- und Gartenbau, Wädenswil, p. 5.
- BOLLER, E. & ALUJA, M. (1992). Oviposition deterring pheromone in *Rhagoletis cerasi* L. -- Journal of Applied Entomology 113, 113-119.
- BOLLER, E. & BUSH, G. L. (1974). Evidence for genetic variation in populations of the European Cherry Fruit Fly, *Rhagoletis cerasi* (Diptera: Tephritidae) based on physiological parameters and hybridization experiments. -- Entomologia experimentalis et applicata 17, 279-293.
- BOLLER, E., HAISCH, A., RUSS, K. & VALLO, V. (1970). Economic importance of *Rhagoletis cerasi* L., the feasibility of genetic control and resulting research problems. -- Entomophaga 15, 305-313.
- BOLLER, E., KATSOYANNOS, B. I. & HIPPE, C. (1998). Host races of *Rhagoletis cerasi* L. (Dipt., Tephritidae): Effect of prior adult experience on oviposition site preference. -- Journal of Applied Entomology 122, 231-237.
- BOLLER, E. & MANI, E. (1994). Two North American *Rhagoletis* spp. in Europe. -- IOBC wprs Bulletin 17, 83-83.
- BOLLER, E. & PROKOPY, R. J. (1976). Bionomics and management of *Rhagoletis*. -- Annual Review of Entomology 21, 223-246.
- BOLLER, E. & RAMSER, E. (1971). Die Zucht der Kirschenfliege (*Rhagoletis cerasi* L.) auf künstlichen Substraten. -- Schweizerische Zeitschrift für Obst- und Weinbau 107, 174-183.
- BOLLER, E. & REMUND, U. (1980). Alternativen zur konventionellen chemischen Bekämpfung der Kirschenfliege, *Rhagoletis cerasi* L., in der Schweiz. -- Schweizerische Zeitschrift für Obst- und Weinbau 116, 320-329.
- (1983). Field feasibility study for the application of SIT in *Rhagoletis cerasi* L. in Northwest Switzerland (1976-1979). -- In: Fruit flies of economic importance (R. Cavalloro, ed). Balkema, Rotterdam, p. 366-370.
- (1989). Qualitative and quantitative life-table studies in *Rhagoletis cerasi* L. in Northwest Switzerland. -- In: Fruit flies of economic importance (L. Cavalloro, ed). Balkema, Rom, p. 25-34.
- BOLLER, E., REMUND, U. & KATSOYANNOS, B. I. (1980). Alternativen zur konventionellen chemischen Bekämpfung der Kirschenfliege. Schlussbericht der Forschungsperiode 1962-1979. -- Internal Report: Eidgenössische Forschungsanstalt für Obst-, Wein- und Gartenbau, Wädenswil, p. 107.
- BOLLER, E., RUSS, K., VALLO, V. & BUSH, G. L. (1976). Incompatible races of European Cherry Fruit Fly, *Rhagoletis cerasi* (Diptera-Tephritidae), their origin and potential use in biological control. -- Entomologia experimentalis et applicata 20, 237-247.
- BOLLER, E. F. (1989b). Rearing - *Rhagoletis* spp. -- In: Fruit flies their biology, natural enemies and control. (A. S. Robinson & G. Hooper, eds). Elsevier, Amsterdam, p. 119-127.
- BUSH, G. L. (1966). The taxonomy, cytology, and evolution of the genus *Rhagoletis* in North America (Diptera, Tephritidae). -- Bulletin of the Museum of comparative Zoology 134, 431-562.
- (1992). Host race formation and sympatric speciation in *Rhagoletis* fruit flies (Diptera: Tephritidae). -- Psyche 99, 335-357.
- CARL, K. P. (1968). Collection of and observation on the natural enemies of *Rhagoletis cerasi*. -- Internal Report: Commonwealth Institute of Biological Control, Delemont, p. 8.

- CARNEIRO, R. M. D. G. & SALLES, L. A. B. (1994). Patogenicidade de *Paecilomyces fumosoroseus*, isolado CG 260 sobre larvas e pupas de *Anastrepha fraterculus* Wied. -- Anais da Sociedade Entomologica do Brasil 23, 341-343.
- CARSWELL, I., SPOONER-HART, R. & MILNER, R. J. (1998). Laboratory susceptibility of *Musca domestica* L. (Diptera: Muscidae) and *Bactrocera tryoni* (Froggatt) (Diptera: Tephritidae) to an isolate of *Metarhizium anisopliae* (Metsch.) Sorokin. -- Australian Journal of Entomology 37, 281-284.
- CARUSO, S. & CERA, M. C. (2004). Control strategies for the cherry fruit fly in organic farming. -- IOBC wprs Bulletin 27, 99-104.
- CASAGRANDE, E., MOLINARI, F., CRAVEDI, P. & BERTONAZZI, C. (1995). Evaluation of new attractants and traps for monitoring of the Cherry Fruit Fly, *Rhagoletis cerasi* L. -- IOBC wprs Bulletin 18, 31-34.
- CASTILLO, M. A., MOYA, P., HERNÁNDEZA, E. & PRIMO-YÚFERAB, E. (2000). Susceptibility of *Ceratitis capitata* Wiedemann (Diptera: Tephritidae) to entomopathogenic fungi and their extracts. -- Biological Control 19, 274-282.
- CAVALCANTI, R. S., JUNIOR, A. M., SOUZA, G. C. & ARNOSTI, A. (2002). Efeito dos produtos fitossanitários fenpropatrina, imidaclopride, Iprodione e tiometoxam sobre o desenvolvimento. -- Arquivos do Instituto Biológico 69, 17-22.
- CIRIO, U. & VITA, G. (1975). Natural chemical substances affecting Cherry Fruit Fly behavior. I. Laboratory trials. -- Conference Proceedings: 5th meeting of the IOBC working group on *Rhagoletis cerasi*, Wädenswil.
- COOK, J. R., BRUCKART, W. L., COULSON, J. R., GOETTEL, M. S., HUMBER, R. A., LUMSDEN, R. D., MADDOX, J. V., MCMANUS, M. L., MOORE, L., MEYER, S. F., QUIMBY, P. C., STACK, J. P. & VAUGHN, J. L. (1996). Safety of microorganisms intended for pest and plant disease control: a framework for scientific evaluation. -- Biological Control 7, 333-351.
- CROSS, J. V., SOLOMON, M. G., CHANDLER, D., JARRETT, P., RICHARDSON, P. N., WINSTANLEY, D., BATHON, H., HUBER, J., KELLER, B., LANGENBRUCH, G. A. & ZIMMERMANN, G. (1999). Biocontrol of Pests of Apples and Pears in Northern and Central Europe: 1. Microbial Agents and Nematodes. -- Biocontrol Science and Technology 9, 125-149.
- DAOUST, R. A. & PEREIRA, R. M. (1986). Stability of entomopathogenic fungi *Beauveria bassiana* and *Metarhizium anisopliae* on beetle-attracting tubers and cowpea foliage in Brazil. -- Environmental Entomology 15, 1237-1243.
- DE LA ROSA, W., LOPEZ, F. L. & LIEDO, P. (2002). *Beauveria bassiana* as a pathogen of the Mexican fruit fly (Diptera: Tephritidae) under laboratory conditions. -- Journal of Economic Entomology 95, 36-43.
- DEDERICHS, U. (2003). Südbaden: Probleme bei der Kirschenfliegenbekämpfung. -- Obstbau 8, 408-409.
- DEPIERI, R. A., MARTINEZ, S. S. & MENEZES, A. O. (2005). Compatibility of the fungus *Beauveria bassiana* (Bals.) Vuill. (Deuteromycetes) with extracts of neem seeds and leaves and the emulsible oil. -- Neotropical Entomology 34, 601-206.
- DESTEFANO, R. H. R., BECHARA, I. J., MESSIAS, C. L. & PIEDRABUENA, A. E. (2005). Effectiveness of *Metarhizium anisopliae* against immature stages of *Anastrepha fraterculus* fruitfly (Diptera: Tephritidae). -- Brazilian Journal of Microbiology 36, 94-99.
- DEVI, K. U., SRIDEVI, V., MOHAN, C. M. & PADMAVATHI, J. (2005). Effect of high temperature and water stress on in vitro germination and growth in isolates of the entomopathogenic fungus *Beauveria bassiana* (Bals.) Vuillemin. -- Journal of Invertebrate Pathology 88, 181-189.
- DIMBI, S., MANIANIA, N. K., LUX, S. A., EKESI, S. & MUEKE, J. K. (2003a). Pathogenicity of *Metarhizium anisopliae* (Metsch.) Sorokin and *Beauveria bassiana* (Balsamo) Vuillemin, to three adult fruit fly species: *Ceratitis capitata* (Weidemann), *C. rosa* var. *fasciventris* Karsch and *C. cosyra* (Walker) (Diptera: Tephritidae). -- Mycopathologia 156, 375-382.
- DIMBI, S., MANIANIA, N. K., LUX, S. A. & MUEKE, J. M. (2003b). Host species, age and sex as factors affecting the susceptibility of the African Tephritid fruit fly species, *Ceratitis capitata*, *C. cosyra* and *C. fasciventris* to infection by *Metarhizium anisopliae*. -- Journal of Pest Science 76, 113-117.
- . (2004). Effect of constant temperatures on germination, radial growth and virulence of *Metarhizium anisopliae* to three species of African tephritid fruit flies. -- BioControl 49, 83-94.
- DOBERSKI, J. W. (1981). Comparative laboratory studies on three fungal pathogens of the Elm Bark Beetle *Scolytus scolytus*: Pathogenicity of *Beauveria bassiana*, *Metarhizium anisopliae*, and *Paecilomyces farinosus* to larvae and adults of *S. scolytus*. -- Journal of Invertebrate Pathology 37, 188-194.

- ECONOMOPOULOS, A. P. (1989). Use of traps based on color and/or shape. -- In: Fruit flies their biology, natural enemies and control. (A. S. Robinson & G. Hooper, eds). Elsevier, Amsterdam, p. 315-327.
- EKESI, S., MANIANIA, N. K. & LUX, S. A. (2002). Mortality in three African tephritid fruit fly puparia and adults caused by the entomopathogenic fungi, *Metarhizium anisopliae* and *Beauveria bassiana*. -- Biocontrol Science and Technology 12, 7-17.
- . (2003). Effect of soil temperature and moisture on survival and infectivity of *Metarhizium anisopliae* to four tephritid fruit fly puparia. -- Journal of Invertebrate Pathology 83, 157-167.
- EKESI, S., MANIANIA, N. K., MOHAMED, S. A. & LUX, S. A. (2005). Effect of soil application of different formulations of *Metarhizium anisopliae* on African tephritid fruit flies and their associated endoparasitoids. -- Biological Control 35, 83-91.
- ENGEL, H. (1969). Versuche zur Bekämpfung der Kirschfruchtfliege mit Leimtafeln. -- Gesunde Pflanzen 21, 197-202.
- . (1976). Untersuchungen über die Besatzdichte der Kirschfruchtfliege (*Rhagoletis cerasi* L.). -- Zeitschrift für Pflanzenkrankheiten und Pflanzenschutz 83, 53-58.
- ENKERLI, J., WIDMER, F. & KELLER, S. (2004). Long-term field persistence of *Beauveria brongniartii* strains applied as biocontrol agents against European cockchafer larvae in Switzerland. -- Biological Control 29, 115-123.
- EPPO. (2003). *Rhagoletis cingulata* n'est pas present en Allemagne. -- Internal Report: EPPO reporting service 2003, No. 1.
- . (2004). *Rhagoletis cingulata* occurs in the Netherlands, but not *R. indifferens*. -- Internal Report: EPPO reporting service 2004, No. 6.
- . (2006). Distribution maps of quarantine pests for Europe - *Rhagoletis cingulata*. -- Internal Report: Eppo: A1 list; EU Annex I/A1.
- EPPO & CABI. (1996). *Rhagoletis cingulata* and *Rhagoletis indifferens*. -- In: Quarantine pests for Europe. (I. M. Smith, D. G. McNamara, P. R. Scott & M. Holderness, eds). CAB INTERNATIONAL, Wallingford, UK.
- EPSKY, N. D. & HEATH, R. R. (1998). Exploiting the interactions of chemical and visual cues in behavioral control measures for pest Tephritid fruit flies. -- Florida Entomologist 81, 273-282.
- ER, M. K. & GÖKÇE, A. (2004). Effects of selected pesticides used against glasshouse tomato pests on colony growth and conidial germination of *Paecilomyces fumosoroseus*. -- Biological Control 31, 398-404.
- FENILI, G. A. (1951). Nuovo contributo alla conoscenza della biologia della mosca delle ciliege (*Rhagoletis cerasi* L.) ed ai mezzi di lotta contro di essa. -- Redia 36, 267-275.
- FENILI, G. A. & ZOCCHI, R. (1954). Esperienze di lotta contro la *Rhagoletis cerasi* L. -- Redia 39, 301-308.
- FIMIANI, P. (1983). Multilarval infestations by *Rhagoletis cerasi* L (Diptera: Trypetidae) in cherry fruits. - In: Fruit flies of economic importance (R. Cavalloro, ed). Balkema, Rotterdam, p. 52-59.
- . (1984). Ricerche bioecologiche sulla mosca della ciliege (*Rhagoletis cerasi* L.) in Campania. II. Distribuzione e intensità delle infestazioni larvali. -- Bollettino del Laboratorio di Entomologia Agraria 'Filippo Silvestri' 41, 13-21.
- . (1989). Pest status - Mediterranean region. -- In: Fruit flies their biology, natural enemies and control. (A. S. Robinson & G. Hooper, eds). Elsevier, Amsterdam, p. 39-50.
- FIMIANI, P., FRILLI, F., INSERRA, S., MONACO, R. & SABATINO, A. (1981). Ricerche coordinate su aspetti bioecologici della *Rhagoletis cerasi* in Italia. -- Bollettino del Laboratorio di Entomologia Agraria 'Filippo Silvestri' 38, 159-211.
- FISCHER-COLBRIE, P. & BUSH-PETERSEN, E. (1989). Pest status -Temperate Europe and West Asia. -- In: Fruit flies their biology, natural enemies and control. (A. S. Robinson & G. Hooper, eds). Elsevier, Amsterdam, p. 91-99.
- FLETCHER, B. S. (1987). The biology of Dacine fruit flies. -- Annual Review of Entomology 32, 115-144.
- . (1989a). Life history strategies of tephritid fruit flies. -- In: Fruit flies their biology, natural enemies and control. (A. S. Robinson & G. Hooper, eds). Elsevier, Amsterdam, p. 195-208.
- . (1989b). Movements of tephritid fruit flies. -- In: Fruit flies their biology, natural enemies and control. (A. S. Robinson & G. Hooper, eds). Elsevier, Amsterdam, p. 209-219.
- . (1989c). Temperature - Development rate relationships of the immature stages and adults of tephritid fruit flies. -- In: Fruit flies their biology, natural enemies and control. (A. S. Robinson & G. Hooper, eds). Elsevier, Amsterdam, p. 273-289.
- FLEXNER, J. L., LIGHTHART, B. & CROFT, B. A. (1986). The effects of microbial pesticides on non-target, beneficial arthropods. -- Agriculture Ecosystems & Environment 16, 203-254.

- FOOTE, R. H. (1981). The genus *Rhagoletis* Loew south of the United States (Diptera: Tephritidae). -- Internal Report: Technical Bulletin No. 1607, US Department of Agriculture, p. 75.
- FRANK, B. (1891). Über die Kirschenfliege *Spilograpta cerasi* und ihre Bekämpfung. -- Zeitschrift für Pflanzenkrankheiten 1, 284-287.
- FRICK, K. E. (1952). Determining emergence of the cherry fruit fly with ammonium carbonate bait traps. -- Journal of Economic Entomology 45, 252-263.
- FRICK, K. E., SIMKOVER, H. G. & TELFORD, H. S. (1954). Bionomics of the cherry fruit flies in Eastern Washington. -- Internal Report: Technical Bulletin 13, Washington Agricultural Experiment Stations, State College of Washington, p. 66.
- GAJEK, D. & OLSZAK, R. (1996). Effectiveness of yellow glue tables in monitoring and control of cherry fruit fly (*Rhagoletis cerasi*). -- Acta Horticulturae, 351-352.
- GALLI, P. (2004). Die Kirschfruchtfliegenbekämpfung steht auf schmaler Basis. -- Besseres Obst, 4-7.
- GARCIA, A. S., MESSIAS, C. L., SOUZA, H. M. L. D. & PIEDRABUENA, A. E. (1984). Patogenicidade de *Metarhizium anisopliae* var. *anisopliae* a *Ceratitidis capitata* (Wied) (Diptera, Tephritidae). -- Revista Brasileira de Entomologia 28, 421-424.
- GARCIA, A. T. E., BARACHO, I. R., DE SOUZA, H. M. L. & MESSIAS, C. L. (1985). Virulência de linhagens mutantes e diplóides de *Metarhizium anisopliae* em *Ceratitidis capitata* (Wied.) (Diptera, Tephritidae). -- Revista Brasileira de Entomologia 29, 267-270.
- GARCIA, A. T. E., SOUZA, H. M. L. D., MESSIAS, C. L. & PIEDRABUENA, A. E. (1989). Patogenicidade de *Metarhizium anisopliae* nas diferentes fases de desenvolvimento de *Ceratitidis capitata* (Wied.) (Diptera, Tephritidae). -- Revista Brasileira de Entomologia 33, 17-24.
- GARDNER, W. A., SUTTON, R. M. & NOBLET, R. (1977). Persistence of *Beauveria bassiana*, *Nomuraea rileyi* and *Nosema necatrix* on soybean foliage. -- Environmental Entomology 6, 616-618.
- GAZIT, Y., RÖSSLER, Y. & GLAZER, I. (2000). Evaluation of entomopathogenic nematodes for the control of mediteranean fruit fly. -- Biocontrol Science and Technology 10, 157-164.
- GEIPEL, K. (2001). Bekämpfung der Kirschfruchtfliege *Rhagoletis cerasi* L. -- Internal Report: Bayerische Landesanstalt für Weinbau und Gartenbau, p. 32.
- . (2002). Bekämpfung der Kirschfruchtfliege *Rhagoletis cerasi* L. - Abschlussbericht. -- Internal Report: Bayerische Landesanstalt für Bodenkultur und Pflanzenbau; Bayerische Landesanstalt für Weinbau und Gartenbau, p. 20.
- GILLESPIE, A. T. (1988). Use of fungi to control pests of agricultural importance. -- In: Fungi in biological control systems (M. N. Burge, ed). Manchester University Press, p. 37-60.
- GINGRICH, R. E. (1987). Demonstration of *Bacillus thuringiensis* as a potential control agent for the Mediterranean fruit fly *Ceratitidis capitata* (Wied.). -- Journal of Applied Entomology 104, 378-385.
- . (1993). Biological control of Tephritid fruit flies by inundative releases of natural enemies. -- In: Fruit flies: Biology and management. (M. Aluja & P. Liedo, eds). Springer Verlag, New York, p. 310-318.
- GOETTEL, M. S., HAJEK, A. E., SIEGEL, J. P. & EVANS, H. C. (2001). Safety of fungal biocontrol agents. -- In: Fungi as biocontrol agents: progress problems and potential. (T. M. Butt, C. W. Jackson & N. Mangan, eds). Cabi Publishing, Wallingford UK, p. 347-375.
- GRODEN, E. (1991). Effects of soil fungistasis on *Beauveria bassiana* and its relationship to disease incidence in the Colorado Potato Beetle, *Leptinotarsa decemlineata*, in Michigan and Rhode Island soils. -- Journal of Invertebrate pathology 57, 7-16.
- GUERIN, P. M., REMUND, U., BOLLER, E., KATSOYANNOS, B. & DELRIO, G. (1983). Fruit fly electroantennogram and behaviour responses to some generally occurring fruit volatiles. -- In: Fruit flies of economic importance (R. Cavalloro, ed). Balkema, Rotterdam, p. 248-251.
- HADERSOLD, O. (1938). Ergebnisse von Parasiten-Zuchten der Zweigstelle Stade der Biologischen Reichsanstalt für Land- und Forstwirtschaft. I. Teil: Ichneumonidae. -- Arbeiten über Physiologische und Angewandte Entomologie Berlin Dahlem 5, 21-32.
- . (1939). Ergebnisse von Parasiten-Zuchten der Zweigstelle Stade der Biologischen Bundesanstalt für Land- und Forstwirtschaft. -- Arbeiten über Physiologische und Angewandte Entomologie Berlin Dahlem 6, 1-14.
- HÄFLIGER, E. (1953). Das Auswahlvermögen der Kirschenfliege bei der Eiablage. -- Mitteilung der Schweizerischen entomologischen Gesellschaft 26, 258-264.
- HAISCH, A. (1975). Zur Puppendiapause der Kirschenfliege *Rhagoletis cerasi* L.- I. Beeinflussung der diapausierenden Puppen durch unterschiedliche Temperaturen und verschieden lange Kälteexpositionen. -- Journal of Applied Entomology 79, 1-11.
- HAISCH, A., BOLLER, E., RUSS, K., VALLO, V. & FIMIANI, P. (1978). The European Cherry Fruit Fly (*Rhagoletis cerasi* Linné 1758) synopsis and bibliography. -- IOBC wprs Bulletin 1.

- HAISCH, A. & CHWALA, D. (1979). Über den Einfluss wechselnder Temperaturen auf den Diapause-Ablauf der Europäischen Kirschfruchtfliege *Rhagoletis cerasi* [Diptera, Trypetidae]. -- Entomologia Generalis 5, 231-239.
- HAISCH, A. & FORSTER, S. (1969). Versuche zur Anköderung und zum Fang der Kirschenfliege (*Rhagoletis cerasi* L.). -- Anzeiger für Schädlingskunde 42, 97-102.
- . (1970). Erfahrungen beim Fang der Kirschenfliege mit Leimtafeln und Leimkugeln. -- Gesunde Pflanzen 22.
- . (1975). Zur herkunftsspezifischen Diapause-Ausprägung der Europäischen Kirschfruchtfliege, *Rhagoletis cerasi* (Diptera: Trypetidae). -- Entomologia Germanica 12, 137-148.
- HAISCH, A., FORSTER, S. & KAMM, J. (1976). Experimentelle Bestimmung der Flugdisposition von Kirschenfliegen *Rhagoletis cerasi* L. (Dipt.:Trypetidae). -- Anzeiger für Schädlingskunde 49, 17-21.
- HAISCH, A. & LEVINSON, H. Z. (1980). Influences of fruit volatiles and coloration on oviposition of the Cherry Fruit Fly. -- Naturwissenschaften 67, 44-45.
- HAJEK, A. E. & LEGER, R. J. S. (1994). Interactions between fungal pathogens and insect hosts. -- Annual Review of Entomology 39, 293-322.
- HÄSELI, A., WEIBEL, F. & TAMM, L. (2005). Überdachungen helfen erfolgreich gegen Pilzkrankheiten. -- Ökologie&Landbau 135, 39-40.
- HEADRICK, D. H. & GOEDEN, R. D. (1998). The biology of nonfrugivorous tephritid fruit flies. -- Annual Review of Entomology 43, 217-241.
- HERZ, A., KÖPPLER, K. & VOGT, H. (2007). Kann der Einsatz entomopathogener Nematoden zur nachhaltigen Bekämpfung der Kirschfruchtfliege beitragen? -- Conference Proceedings: 9. Wissenschaftstagung Ökologischer Landbau, Universität Hohenheim, Stuttgart, Deutschland.
- HOFFMEISTER, T. (1992a). Aspekte der Partnerfindung, Konkurrenz und Parasitierung frugivorer Bohrfliegen (Diptera: Tephritidae). -- Thesis: PhD, Christian Albrechts Universität Kiel, p. 140.
- . (1992b). Factors determining the structure and diversity of parasitoid complexes in Tephritid Fruit Flies. -- Oecologia 89, 288-297.
- . (1993). The parasitoid complexes of frugivorous fruit flies of central Europe. -- In: Fruit flies: Biology and management. (M. Aluja & P. Liedo, eds). Springer Verlag, New York, p. 125-127.
- HOWITT, A. J. & CONNOR, L. J. (1965). The response of *Rhagoletis pomonella* (Walsh) adults and other insects to trap boards baited with protein hydrolysate baits. -- Proceedings of the Entomological Society of Ontario 95, 134-136.
- HUBER, L., LEITHER, E., EISENBEIS, G., PORTEN, M. & KIRCHMAIR, M. (2004). *Metarhizium anisopliae* - ein Bodenpilz zur biologischen Kontrolle der Reblaus. -- Conference Proceedings: Intervitis Interfructa 1. Internationales Symposium für ökologischen Weinbau., Stuttgart, Germany, 12-23.
- HURTER, J., BOLLER, E., STÄDLER, E., RASCHDORF, F. & SCHREIBER, J. (1989). Oviposition-detering pheromone in *Rhagoletis cerasi* L. Purification and determination of the chemical constitution. -- In: Fruit flies of economic importance (R. Cavalloro, ed). Balkema, Rotterdam, p. 147-149.
- IGNOFFO, C. M. (1992). Environmental factors affecting persistence of entomopathogens. -- Florida Entomologist 75, 516-525.
- INGLIS, G. D., GOETTEL, M. S., BUTT, T. M. & STRASSER, H. (2001). Use of hyphomycetous fungi for managing insect pests. -- In: Fungi as biocontrol agents: progress problems and potential. (T. M. Butt, C. W. Jackson & N. Mangan, eds). Cabi Publishing, Wallingford UK, p. 23-69.
- INGLIS, G. D., GOETTEL, M. S. & JOHNSON, D. L. (1993). Persistence of the entomopathogenic fungus *Beauveria bassiana* on Phylloplanes of crested wheatgrass and alfalfa. -- Biological Control 3, 258-270.
- . (1995). Influence of ultraviolet light protectants on persistence on the entomopathogenic fungus *Beauveria bassiana*. -- Biological Control 5, 581-590.
- JAASTAD, G. (1994). First registration of the Cherry Fruit Fly, *Rhagoletis cerasi* (L.) in western Norway: Distribution, size and origin of the population. -- Norwegian Journal of Agricultural Sciences 8, 203-214.
- . (1998). Male mating success and body size in the European Cherry Fruit Fly, *Rhagoletis cerasi* L. (Dipt., Tephritidae). -- Journal of Applied Entomology 122, 121-124.
- JAMES, R. R., SHAFFER, B. T., CROFT, B. A. & LIGHTHART, B. (1995). Field evaluation of *Beauveria bassiana*: its persistence and effects on the Pea Aphid and a non-target Coccinellid in Alfalfa. -- Biocontrol Science and Technology 5, 425-437.
- JANCKE, O. & BÖHMEL, W. (1933). Beitrag zur Biologie und Bekämpfung der Kirschenfliege. -- Arbeiten der biologischen Reichsanstalt 20, 443-456.

- JAROS-SU, J., GRODEN, E. & ZHANG, J. (1999). Effects of selected fungicides and the timing of fungicide application on *Beauveria bassiana* induced mortality of the Colorado Potato Beetle (Coleoptera: Chrysomelidae). -- *Biological Control* 15, 259-269.
- KARABHANTANAL, S. S. & AWAKNAVAR, J. S. (2005). Persistence of bio-control agents on tomato fruits under field conditions. -- *Pest Management and Economic Zoology* 13, 83-87.
- KARRER, R., PFAFF, H. W., KRAUSS, D. & SCHILDKNECHT, H. (1990). Das Eiablageverhalten der Kirschfruchtfliege *Rhagoletis cerasi* L. unter Einfluss der flüchtigen Inhaltsstoffe der Früchte von Wirts- und Nichtwirtspflanzen. -- *Chemiker-Zeitung* 114, 151-158.
- KARSCH, F. (1889). Oekonomisch-entomologische Notizen: Die Kirschenfliege. -- *Entomologische Nachrichten* 15, 384.
- KATSOYANNOS, B. I. (1975). Oviposition-deterring, male-arresting, fruit-marking pheromone in *Rhagoletis cerasi*. -- *Environmental Entomology* 4, 801-807.
- . (1976). Female attraction to males in *Rhagoletis cerasi* (Diptera: Tephritidae). -- *Environmental Entomology* 5, 474-476.
- . (1979). Zum Reproduktions und Wirtswahlverhalten der Kirschenfliege, *Rhagoletis cerasi* L. (Diptera: Tephritidae). -- Thesis: phd (Thesis no. 6409), ETH Zürich, p. 116.
- . (1982). Male sex pheromone of *Rhagoletis cerasi* L. (Diptera, Tephritidae): Factors affecting release and response and its role in mating behavior. -- *Journal of Applied Entomology* 94, 187-198.
- . (1989a). Mating Pheromones - *Rhagoletis* ssp. -- In: *Fruit flies their biology, natural enemies and control*. (A. S. Robinson & G. Hooper, eds). Elsevier, Amsterdam, p. 185-188.
- . (1989b). Response to shape, size and color. -- In: *Fruit flies their biology, natural enemies and control*. (A. S. Robinson & G. Hooper, eds). Elsevier, Amsterdam, p. 307-324.
- KATSOYANNOS, B. I., BOLLER, E. & BENZ, G. (1986). Das Verhalten der Kirschenfliege, *Rhagoletis cerasi* L., bei der Auswahl der Wirtspflanzen und ihre Dispersion. -- *Mitteilung der Schweizerischen entomologischen Gesellschaft* 59, 315-335.
- . (1987). Zur Reproduktionsbiologie der Kirschenfliege *Rhagoletis cerasi* L.: Präovipositionsperiode, Tagesperiodizität und Einfluss der Kopulation auf die Fekundität und Fertilität einzeln oder in Gruppen gehaltener Weibchen (Diptera: Tephritidae). -- *Mitteilung der Schweizerischen entomologischen Gesellschaft* 60, 3-13.
- KATSOYANNOS, B. I., BOLLER, E. & REMUND, U. (1977). Beitrag zur Entwicklung von Methoden für die Massenzucht der Kirschenfliege *Rhagoletis cerasi* L., auf künstlichen Substraten. -- *Mitteilung der Schweizerischen entomologischen Gesellschaft* 50, 25-33.
- . (1980). A simple olfactometer for the investigation of sex pheromones and other olfactory attractants in Fruit Flies and moth. -- *Journal of Applied Entomology* 90, 105-112.
- KATSOYANNOS, B. I. & BOLLER, E. F. (1976). First field application of oviposition-deterring marking pheromone of European cherry fruit fly *Rhagoletis cerasi* L. -- *Environmental Entomology* 5, 151-152.
- . (1980). Second field application of oviposition-deterring pheromone of the European cherry fruit fly, *Rhagoletis cerasi* L. (Diptera, Tephritidae). -- *Zeitschrift für angewandte Entomologie* 89, 278-281.
- KATSOYANNOS, B. I., PAPADOPOULOS, N. T. & STAVRIDIS, D. (2000). Evaluation of trap types and food attractants for *Rhagoletis cerasi* (Diptera: Tephritidae). -- *Journal of Economic Entomology* 93, 1005-1010.
- KELLER, S., KESSLER, P. & SCHWEIZER, C. (2003). Distribution of insect pathogenic soil fungi in Switzerland with special reference to *Beauveria brongniartii* and *Metarhizium anisopliae*. -- *BioControl* 48, 307-319.
- KESSLER, P., MATZKE, H. & KELLER, S. (2003). The effect of application time and soil factors on the occurrence of *Beauveria brongniartii* applied as a biological control agent in soil. -- *Journal of Invertebrate pathology* 84, 15-23.
- KLINGEN, I., EILENBERG, J. & MEADOW, R. (2002). Effects of farming system, field margins and bait insect on the occurrence of insect pathogenic fungi in soils. -- *Agriculture Ecosystems & Environment* 91, 191-198.
- KOBEL, F. (1933). Eine Notiz über das Vorkommen der Kirschenfruchtfliege im 16. Jahrhundert. -- *Schweizerische Zeitschrift für Obst- und Weinbau* 42, 255.
- KONSTANTOPOULOU, M. A. & MAZOMENOS, B. E. (2005). Evaluation of *Beauveria bassiana* and *B. brongniartii* strains and four wild-type fungal species against adults of *Bactrocera oleae* and *Ceratitidis capitata*. -- *Biocontrol* 50, 293-305.
- KÖPPLER, K., PETERS, A., STORCH, V. & VOGT, H. (2005a). Fly-free cherries: utopia or realistic hope? -- *IOBC wprs Bulletin* 28, 143-149.

- KÖPPLER, K., PETERS, A. & VOGT, H. (2005b). Initial results in the application of entomopathogenic nematodes against the European cherry fruit fly *Rhagoletis cerasi* L. (Diptera: Tephritidae). -- IOBC wprs Bulletin 28, 13-18.
- KOUASSI, M., CODERRE, D. & TODOROVA, S. I. (2003). Effect of plant type on the persistence of *Beauveria bassiana*. -- Biocontrol Science and Technology 13, 415-427.
- KOVANCI, O. B. & KOVANCI, B. (2006). Effect of altitude on seasonal flight activity of *Rhagoletis cerasi* flies (Diptera: Tephritidae). -- Bulletin of Entomological research 96, 345-351.
- KUSKE, S., DANIEL, C., WYSS, E., SARRAQUIGNE, J., JERMINI, M., CONEDERA, M. & GRUNDER, M. (2005). Biocontrol potential of entomopathogenic nematodes against nut and orchard pests. -- IOBC wprs Bulletin 28, 163-167.
- LAMPE, I., BURGHause, F. & KRAUTHAUSEN, H. J. (2005). Introduction and distribution of the American cherry fruit fly *Rhagoletis cingulata* in the Rhine Valley, Germany. -- Conference Proceedings: Plant Protection and Plant Health in Europe; Introduction and Spread of Invasive Species, Humboldt University, Berlin, Germany.
- LAMPE, I., DAHLBENDER, W., HARZER, U., HENSEL, G. & KRAUTHAUSEN, H. J. (2006). Die Amerikanische Kirschfruchtfliege (*Rhagoletis cingulata*) - Untersuchungen zum Auftreten in Rheinland-Pfalz. - - Obstbau, 414-416.
- LESKI, R. (1963). Studia nad biologią i ekologią nasionnicy tżresniowki *Rhagoletis cerasi* L. (Diptera: Trypetidae). -- Polskie Pismo Entomologiczne Seria B, Zeszyt 3-4 (31-32), 153-240.
- LEVINSON, H. Z. & HAISCH, A. (1983). Optical and chemosensory stimuli involved in host recognition and oviposition of the cherry fruit fly *Rhagoletis cerasi* L. -- In: Fruit flies of economic importance (R. Cavalloro, ed). Balkema, Rotterdam, p. 268-275.
- . (1984). Optical and chemosensory stimuli involved in host recognition and oviposition of the Cherry Fruit Fly *Rhagoletis cerasi* L. -- Zeitschrift für angewandte Entomologie 97, 85-91.
- LEZAMA-GUTIERREZ, R., TRUJILLO-DE LA LUZ, A., MOLINA-OCHA, J., REBOLLEDO-DOMINGUEZ, O., PESCADOR, A. R., LOPEZ-EDWARDS, M. & ALUJA, M. (2000). Virulence of *Metarhizium anisopliae* on *Anastrepha ludens*: Laboratory and field trials. -- Journal of Economic Entomology 93, 1080-1084.
- LIBURD, O. E., STELINSKY, L. L., GUT, L. J. & THORNTON, G. (2001). Performance of various trap types for monitoring populations of Cherry Fruit fly (Diptera: Tephritidae) species. -- Environmental Entomology 30, 82-88.
- LINDGREN, J. E. & VAIL, P. V. (1986a). Response of Mediterranean fruit fly, Melon fly and Oriental fruit fly (Diptera:Tephritidae) to the entomogenous nematode *Steinernema feltiae* in field tests in Hawaii. -- Environmental Entomology 19, 383-386.
- . (1986b). Susceptibility of Mediterranean fruit fly, Melon fly and Oriental fruit fly (Diptera:Tephritidae) to the entomogenous nematode *Steinernema feltiae* in laboratory tests. -- Environmental Entomology 15, 465-468.
- LINGG, A. J. & DONALDSON, M. D. (1981). Biotic and abiotic factors affecting stability of *Beauveria bassiana* conidia in soil. -- Journal of Invertebrate pathology 38, 191-200.
- LIU, Z. Y., MILNER, R. J., MCRAE, C. F. & LUTTON, G. G. (1993). The use of dodine in selective media for the isolation of *Metarhizium* spp. from soil. -- Journal of Invertebrate pathology 62, 248-251.
- LOPEZ, M., ALUJA, M. & SIVINSKI, J. (1999). Hymenopterous larval-pupal and pupal parasitoids of *Anastrepha* flies (Diptera: Tephritidae) in Mexico. -- Biological Control 15, 119-129.
- LUANGSA-ARD, J. J., HYWEL-JONES, N. L., MANOCH, L. & SAMSON, R. A. (2005). On the relationship of *Paecilomyces* sect. *Isarioidea* species. -- Mycological Research 109, 581-589.
- LUKE, B. M. & BATEMAN, R. P. (2006). Effects of chemical and botanical insecticides used for locust control on *Metarhizium anisopliae* var. *acridum* conidia after short- to medium-term storage at 30°C. -- Biocontrol Science and Technology 16, 761-766.
- MADÉLIN, M. F. (1966). Fungal parasites of insects. -- Annual Review of Entomology 11, 423-448.
- MANI, E., MERZ, B., BRUNETTI, R., SCHAUB, L., JERMINI, M. & SCHWALLER, F. (1994). Zum Auftreten der beiden amerikanischen Fruchtfliegenarten *Rhagoletis completa* Cresson und *Rhagoletis indifferens* Curran in der Schweiz (Diptera: Tephritidae). -- Mitteilung der Schweizerischen entomologischen Gesellschaft 67, 177-182.
- MANIANIA, N. K. & ODULAJA, A. (1998). Effect of species, age, and sex of tsetse on response to infection by *Metarhizium anisopliae*. -- BioControl 43, 311-323.
- MANOUSIS, T. & MOORE, N. F. (1989). The search for viruses pathogenic for the olive fruit fly, *Dacus oleae* Gmelin. -- In: Fruit flies of economic importance (R. Cavalloro, ed). Balkema, Rotterdam, p. 349-353.

- MARJANSKA-CICHON, B., MIETKIEWSKI, R. & SAPIEHA-WASZKIEWICZ, A. (2005). Występowanie i skład gatunkowy grzybow owadobojczych w glebach z sadow jabloniowych. -- *Acta Agrobotanica* 58, 113-124.
- MARTINEZ, A. J., ROBACKER, D. C. & GARCIA, J. A. (1997). Toxicity of an isolate of *Bacillus thuringiensis* subspecies *darmsi* to adults of the Mexican fruit fly (Diptera: Tephritidae) in the laboratory. -- *Journal of Economic Entomology* 90, 130-134.
- MATOLIN, S. (1976). Mechanism causing incompatibility between different strains of *Rhagoletis cerasi* (Diptera, Tephritidae). -- *Acta Entomologica Bohemoslovaca* 73, 289-292.
- MAYER, D. F., LONG, L. E., SMITH, T. J., OLSEN, J., RIEDL, H., HEATH, R. R., LESKEY, T. C. & PROKOPY, R. J. (2000). Attraction of adult *Rhagoletis indifferens* (Diptera : Tephritidae) to unbaited and odor-baited red spheres and yellow rectangles. -- *Journal of Economic Entomology* 93, 347-351.
- MEADOW, R., VANDENBERG, J. D. & SHELTON, A. M. (2000). Exchange of inoculum of *Beauveria bassiana* (Bals.) Vuill. (Hyphomycetes) between adult flies of the cabbage maggot *Delia radicum* L. (Diptera : Anthomyiidae). -- *Biocontrol Science and Technology* 10, 479-485.
- MEIER, K. (1932). Das Auftreten der Kirschenfliege. -- *Schweizerische Zeitschrift für Obst- und Weinbau* 41, 148-150.
- MÉNEGAUX, R. (1898). Le ver de cerises. -- *Le Naturaliste*, 212.
- MERZ, B. (1991). *Rhagoletis completa* Cresson und *Rhagoletis indifferens* Curran zwei wirtschaftlich bedeutende nordamerikanische Fruchtfliegen neu für Europa (Diptera: Tephritidae). -- *Mitteilung der Schweizerischen entomologischen Gesellschaft* 64, 55-57.
- MEYLING, N. V. & EILENBERG, J. (2006). Isolation and characterisation of *Beauveria bassiana* isolates from phylloplanes of hedgerow vegetation. -- *Mycological Research* 110, 188-195.
- MIETKIEWSKI, R. T., PELL, J. K. & CLARK, S. J. (1997). Influence of pesticide use on the natural occurrence of entomopathogenic fungi in arable soils in the UK: field and laboratory comparisons. -- *Biocontrol Science and Technology* 7, 565-575.
- MIK, J. (1898). Zur Biologie von *Rhagoletis cerasi* L. nebst einigen Bemerkungen über die Larven und Puparien der Trypetiden und über die Fühler der Musciden-Larven. -- *Wiener Entomologen Zeitung* 17, 279-313.
- MOCHI, D. A., MONTEIRO, A. C. & BARBOSA, J. C. (2005). Action of pesticides to *Metarhizium anisopliae* in soil. -- *Neotropical Entomology* 34, 961-971.
- MOCHI, D. A., MONTEIRO, A. C., DE BORTOLI, S. A., DORIA, H. O. S. & BARBOSA, J. C. (2006). Pathogenicity of *Metarhizium anisopliae* for *Ceratitidis capitata* (Wied.) (Diptera: Tephritidae) in soil with different pesticides. -- *Neotropical Entomology* 35, 382-389.
- MONACO, R. (1984). *L'Opus magnus* Fischer (Braconidae), parassita di *Rhagoletis cerasi* L. su *Prunus mahaleb*. -- *Entomologica* 19, 75-80.
- MOUSSA, A. Y. (1978). A new cytoplasmic inclusion virus from Diptera in the Queensland fruit fly, *Dacus tryoni* (Frogg) (Diptera: Tephritidae). -- *Journal of Invertebrate Pathology* 32, 77-87.
- MÜLLER, W. (1970). Agrarmeteorologische Untersuchungen über das Erstauftreten der Kirschenfliege (*Rhagoletis cerasi* L.) in Österreich. -- *Pflanzenschutzberichte* 41, 193-209.
- NARAYANAN, E. S. & CHAWLA, S. S. (1962). Parasites of fruit fly pests of the world. -- *Beiträge zur Entomologie* 12, 437-476.
- NAVROZIDIS, E. I., VASARA, E., KARAMANLIDOU, G., SALPIGGIDIS, G. K. & KOLIAIS, S. I. (2000). Biological control of *Bactrocera oleae* (Diptera : Tephritidae) using a Greek *Bacillus thuringiensis* isolate. -- *Journal of Economic Entomology* 93, 1657-1661.
- NEUENSCHWANDER, P. (1982). Beneficial insects caught by yellow traps used in mass trapping of the olive fly, *Dacus oleae*. -- *Entomologia experimentalis et applicata* 32, 286-296.
- NEUENSCHWANDER, P., MICHELAKIS, S., RUSS, K. & HÖBAUS, E. (1983). Ecological studies on *Rhagoletis cerasi* L. in Crete for the use of incompatible insect technique. -- In: *Fruit flies of economic importance* (R. Cavalloro, ed). Balkema, Rotterdam, p. 41-51.
- NGUYEN, V. L., MEATS, A., BEATTIE, G. A. C., SPOONER-HART, R., LIU, Z. M. & JIANG, L. (2007). Behavioural responses of female Queensland fruit fly, *Bactrocera tryoni*, to mineral oil deposits. -- *Entomologia experimentalis et applicata* 122, 215-221.
- OVRUSKI, S. M., ALUJA, M., SIVINSKI, J. & WHARTON, R. A. (2000). Hymenopteran parasitoids on fruit infesting Tephritidae (Diptera) in Latin America and the southern United States: diversity, distribution, taxonomic status and their use in biological control. -- *Integrated Pest Management Reviews* 5, 81-107.
- PARKER, B. L., SKINNER, M., GOULI, V. & BROWNBRIDGE, M. (1997). Impact of soil applications of *Beauveria bassiana* and *Mariannaea* sp. on nontarget forest arthropods. -- *Biological Control* 8, 203-206.

- PATTERSON STARK, J. E. & LACEY, L. A. (1999). Susceptibility of Western cherry fruit fly (Diptera: Tephritidae) to five species of entomopathogenic nematodes in laboratory studies. -- *Journal of Invertebrate pathology* 74, 206-208.
- PELZ-STELINSKI, K. S., GUT, L. J., STELINSKI, L. L., LIBURD, O. E. & ISAACS, R. (2005). Captures of *Rhagoletis mendax* and *R. cingulata* (Diptera : Tephritidae) on sticky traps are influenced by adjacent host fruit and fruit juice concentrates. -- *Environmental Entomology* 34, 1013-1018.
- PINERO, J., ALUJA, M., VAZQUEZ, A., EQUIHUA, M. & VARON, J. (2003). Human urine and chicken feces as Fruit Fly (Diptera: Tephritidae) attractants for resource-poor fruit growers. -- *Journal of Economic Entomology* 96, 334-340.
- PLUS, N. (1989). The reoviruses of Trypetidae, Drosophilidae and Muscidae - a review. -- In: *Fruit flies of economic importance* (R. Cavalloro, ed). Balkema, Rotterdam, p. 355-358.
- PLUS, N. & CAVALLORO, R. (1983). The viruses of *Ceratitidis capitata* Wied. in vivo and in vitro. -- In: *Fruit flies of economic importance* (R. Cavalloro, ed). Balkema, Rotterdam, p. 106-112.
- PROKOPY, R. J. (1968). Visual responses of Apple Maggot Flies, *Rhagoletis pomonella* (Diptera: Tephritidae): Orchard studies. -- *Entomologia experimentalis et applicata* 11, 403-422.
- . (1969). Visual responses of European cherry fruit flies - *Rhagoletis cerasi* L. (Diptera, Trypetidae). -- *Polskie Pismo Entomologiczne* 39, 539-566.
- . (1971). Orientation of the apple maggot flies *Rhagoletis pomonella* (Walsh) and European cherry fruit flies *R. cerasi* L. (Diptera: Tephritidae) to visual stimuli. -- *Conference Proceedings: 13 International Congress of Entomology, Moscow*, 34-35.
- . (1974). Selective new trap for *Rhagoletis cingulata* and *R. pomonella* flies. -- *Environmental Entomology* 4, 420-424.
- PROKOPY, R. J. & BOLLER, E. (1969). Artificial eggging system for the European Cherry Fruit Fly. -- *Journal of Economic Entomology* 63, 1413-1417.
- . (1971a). Response of European Cherry Fruit Flies to colored rectangles. -- *Journal of Economic Entomology* 64, 1444-1447.
- . (1971b). Stimuli eliciting oviposition of European cherry fruit flies, *Rhagoletis cerasi* (Diptera: Tephritidae), into inanimate objects. -- *Entomologia experimentalis et applicata* 14, 1-14.
- PROKOPY, R. J., MITTENTHAL, R. E. & WRIGHT, S. E. (2003). Evaluation of trap deployment patterns for behavioral control of Apple Maggot Flies (Dipt., Tephritidae). -- *Journal of Applied Entomology* 127, 276-281.
- PRONK, W., ZULEEG, S., LIENERT, J., ESCHER, B., KOLLER, M., BERNER, A., KOCH, G. & BOLLER, M. (2007). Pilot experiments with electro dialysis and ozonation for the production of a fertiliser from urine. -- *Water science and technology* 56, 219-227.
- QUESEDA-MORAGA, E., RUIZ-GARCIA, A. & SANTIAGO-ALVAREZ, C. (2006). Laboratory evaluation of entomopathogenic fungi *Beauveria bassiana* and *Metarhizium anisopliae* against puparia and adults of *Ceratitidis capitata* (Diptera: Tephritidae). -- *Journal of Economic Entomology* 99, 1955-1966.
- R DEVELOPMENT CORE TEAM. (2006). R: A language and environment for statistical computing. R Foundation for Statistical Computing. -- Electronic source: <http://www.R-project.org>.
- RANNER, H. (1987a). Untersuchungen zur Biologie und Bekämpfung der Kirschfruchtfliege, *Rhagoletis cerasi* L. (Diptera, Trypetidae) - I. Die Bedeutung der wilden Wirtspflanzen für die Epidemiologie und die ökologische Differenzierung der Kirschfruchtfliege. -- *Pflanzenschutzberichte* 48, 42-51.
- . (1987b). Untersuchungen zur Biologie und Bekämpfung der Kirschfruchtfliege, *Rhagoletis cerasi* L. (Diptera, Trypetidae) - II. Statistischer Vergleich von Eiern und Puparien der Kirschfruchtfliege aus verschiedenen Wirtspflanzen, von verschiedenen Sammelorten und -jahren. -- *Pflanzenschutzberichte* 48, 27-43.
- . (1988a). Untersuchungen zur Biologie und Bekämpfung der Kirschfruchtfliege, *Rhagoletis cerasi* L. (Diptera, Trypetidae) - III. Statistischer Vergleich der Schlupfperioden und Schlupfraten der Kirschfliege. -- *Pflanzenschutzberichte* 49, 17-26.
- . (1988b). Untersuchungen zur Biologie und Bekämpfung der Kirschfruchtfliege, *Rhagoletis cerasi* L. (Diptera, Trypetidae) - IV. Statistische Auswertung von Kreuzenversuchen mit Kirschfliegen verschiedenen Alters and Puppengewichts, verschiedener Wirtspflanzenherkunft und Rassenzugehörigkeit. -- *Pflanzenschutzberichte* 49, 74-86.
- . (1990). Untersuchungen zur Biologie und Bekämpfung der Kirschfruchtfliege, *Rhagoletis cerasi* L. (Diptera, Trypetidae) - V. Versuche zur Bekämpfung der Kirschfruchtfliege mit Hilfe der Incompatible Insect Technique (IIT). -- *Pflanzenschutzberichte* 51, 1-16.

- RAPTOPOULOS, D., HANIOTAKIS, G., KOUTSAFTIKIS, A., KELLY, D. & MAVRAGANIS, V. (1995). Biological activity of chemicals identified from extracts and volatiles of male *Rhagoletis cerasi*. -- Journal of Chemical Ecology 21, 1287-1297.
- REISSIG, W. H. (1976). Comparison of traps and lures for *Rhagoletis fausta* and *Rhagoletis cingulata*. - Journal of Economic Entomology 69, 639-643.
- REMUND, U. (1971). Anwendungsmöglichkeiten einer wirksamen visuellen Wegwerffalle für die Kirschenfliege. -- Schweizerische Zeitschrift für Obst- und Weinbau 107, 199-205.
- REMUND, U. & BOLLER, E. (1971). Neuerungen im Schweizer Prognosewesen für die Kirschenfliege. -- Schweizerische Zeitschrift für Obst- und Weinbau 107, 185-198.
- . (1975). Qualitätskontrolle von Insekten: die Messung von Flugparametern. -- Zeitschrift für angewandte Entomologie 78, 113-126.
- . (1978). Kirschenfliegenfallen für Prognosewesen und biotechnische Bekämpfung im Vormarsch. -- Schweizerische Zeitschrift für Obst- und Weinbau 114, 229-232.
- . (1983). Pièges visuels pour la lutte biotechnique et prévision négative de la mouche de la cerise, *Rhagoletis cerasi* L. -- In: Fruit flies of economic importance (R. Cavalloro, ed). Balkema, Rotterdam, p. 490-494.
- REMUND, U. & BOLLER, E. F. (1976). Size criteria for adults and for sexing pupae of *Rhagoletis cerasi* Diptera-Tephritidae. -- Journal of Economic Entomology 69, 136-138.
- REYNOLDS, K. M., OPP, S. B., MOEN, M. & DENHAM, K. (1996). Mark-recapture studies of walnut husk flies attracted to food-based lures. -- In: Fruit fly pests - a world assessment of their biology and management. (B. A. McPherson & G. J. Steck, eds). St. Lucie Press, Delray Beach, p. 141-146.
- RIEGLER, M. (2002). Der Endosymbiont Wolbachia (alpha-Proteobacteria) in der europäischen Kirschfruchtfliege *Rhagoletis cerasi* (Diptera, Tephritidae): Populationsdynamik und Einfluss auf die Populationsgenetik. -- Thesis: PhD, Universität für Bodenkultur Wien, p. 83.
- RIEGLER, M. & STAUFFER, C. (2002). Wolbachia infections and superinfections in cytoplasmically incompatible populations of the European cherry fruit fly *Rhagoletis cerasi* (Diptera, Tephritidae). -- Molecular Ecology 11, 2425-2434.
- RIZZO, D. C. (1977). Age of three dipteran hosts as a factor governing the pathogenicity of *Beauveria bassiana* and *Metarhizium anisopliae*. -- Journal of Invertebrate pathology 30, 127-130.
- ROBACKER, D. C. (1995). Attractiveness of a mixture of ammonia, methylamine and putrescine to Mexican Fruit Flies (Diptera: Tephritidae) in a citrus orchard. -- Florida Entomologist 78, 571-578.
- ROBACKER, D. C., MARTINEZ, J. A., GARCIA, J. A., DIAZ, M. & ROMERO, C. (1996). Toxicity of *Bacillus thuringiensis* to Mexican fruit fly (Diptera: Tephritidae). -- Journal of Economic Entomology 89, 104-110.
- ROESSLER, Y. (1989). Insecticidal bait and cover sprays. -- In: Fruit flies their biology, natural enemies and control. (A. S. Robinson & G. Hooper, eds). Elsevier, Amsterdam, p. 329-336.
- ROY, H. E. & PELL, J. K. (2000). Interactions between entomopathogenic fungi and other natural enemies: implications for biological control. -- Biocontrol Science and Technology 10, 737-752.
- RUSS, K., BOLLER, E., VALLO, V., HAISCH, A. & SEZER, S. (1973). Development and application of visual traps for monitoring and control of populations of *Rhagoletis cerasi* L. -- Entomophaga 18, 103-116.
- SACHTLEBEN, H. (1934). Deutsche Parasiten der Kirschfruchtfliege (Hym. Ichneumonoidea und Proctotrypoidea). -- Arbeiten über Morphologische und Taxonomische Entomologie aus Berlin Dahlem 1, 76-83.
- SAJO, K. (1902a). Die Kirschfliege *Spilograpta cerasi*. -- Pomologische Monatshefte 48, 155-157.
- . (1902b). Zur Entwicklung der Kirschfliege. -- Prometheus 14, 3-4.
- SAMOGGIA, A. (1932). Nota sulla *Rhagoletis cerasi* L. -- Bollettino del Laboratorio di Entomologia del R. Istituto Superiore Agrario 5, 22-48.
- SAMUELS, K. D. Z., PINNOCK, D. E. & ALLSOPP, P. G. (1989). The potential of *Metarhizium anisopliae* (Metschnikoff) Sorokin (Deuteromycotina, Hyphomycetes) as a biological control agent of *Inopus rubriceps* (Macquart) (Diptera, Stratiomyidae). -- Journal of the Australian Entomological Society 28, 69-74.
- SCHNEIDER, F. (1947). Methoden zur Ermittlung des Kirschenfliegenbefalls. -- Schweizerische Zeitschrift für Obst- und Weinbau 56, 374-375.
- SCHWARZ, D., MCPHERON, B. A., HARTL, G. B., BOLLER, E. F. & HOFFMEISTER, T. S. (2003). A second case of genetic host races in *Rhagoletis*? A population genetic comparison of sympatric host

- populations in the European cherry fruit fly, *Rhagoletis cerasi*. -- Entomologia experimentalis et applicata 108, 11-17.
- SCHWOPE, D. (1957). Untersuchungen zur Anwendung des Wirkstoffnebelverfahrens bei der Bekämpfung der Kirschfruchtfliege (*Rhagoletis cerasi* L.). -- Wissenschaftliche Zeitschrift der Martin-Luther-Universität Halle-Wittenberg 6, 615-622.
- SEIFERT, G. (1961). Untersuchungen über den Schlüpftermin der Kirschenfliege. -- Zeitschrift für Pflanzenkrankheiten und Pflanzenschutz 68, 198-207.
- SHIPP, J. L., ZHANG, Y., HUNT, D. W. A. & FERGUSON, G. (2003). Influence of humidity and greenhouse microclimate on the efficacy of *Beauveria bassiana* (Balsamo) for control of greenhouse arthropod pests. -- Environmental Entomology 32, 1154-1163.
- SIMKOVER, H. G. (1953). *Rhagoletis cingulata* on wild and cultivated cherries in eastern Washington. -- Journal of Economic Entomology 46, 896-897.
- SIVINSKI, J. & BURK, T. (1989). Reproductive and mating behavior. -- In: Fruit flies their biology, natural enemies and control. (A. S. Robinson & G. Hooper, eds). Elsevier, Amsterdam, p. 343-351.
- SIVINSKI, J., VULINEC, K. & ALUJA, M. (2001). Ovipositor length in a guild of parasitoids (Hymenoptera: Braconidae) attacking *Anastrepha* spp. Fruit Flies (Diptera: Tephritidae) in Southern Mexico. -- Annals of the entomological Society of America 94, 886-895.
- SIVINSKI, J., VULINEC, K., MENEZES, E. & ALUJA, M. (1998). The bionomics of *Coptera haywardi* (Ogloblin) (Hymenoptera: Diapriidae) and other pupal parasitoids of Tephritid Fruit Flies (Diptera). -- Biological Control 11, 193-202.
- SMITS, N., FARGUES, J. & ROUGIER, M. (1997). Modelling the persistence of quiescent conidia of the entomopathogenic Hyphomycete *Paecilomyces fumosoroseus* exposed to solar radiation. -- Biocontrol Science and Technology 7, 365-375.
- SPEYER, W. (1941). Beobachtungen über das Zahlenverhältnis der Geschlechter bei der Kirschfruchtfliege (*Rhagoletis cerasi* L.). -- Zeitschrift für Pflanzenkrankheiten und Pflanzenschutz 51, 330-332.
- SPRENGEL, L. (1931). Die Kirschfliege und ihre wirtschaftliche Bedeutung. -- Der Obst- und Gemüsebau 5, 76-77.
- . (1932a). Biologische und epidemiologische Untersuchungen als Grundlage für die Bekämpfung der Kirschfruchtfliege *Rhagoletis cerasi* L. -- Gartenbauwissenschaft 6, 541-553.
- . (1932b). Die Bekämpfung der Kirschfruchtfliege (*Rhagoletis cerasi* L.). -- Anzeiger für Schädlingskunde 8, 47-51.
- . (1932c). Kirschfruchtfliege und ihre Bekämpfung. -- Internal Report: Flugblatt 83, 3. Auflage, Biologische Reichsanstalt für Land- und Forstwirtschaft.
- SPRENGEL, L. & SONNTAG, K. (1932). Der Flug der Kirschfliege (*Rhagoletis cerasi* L.) in seiner Bedeutung zu Fruchtreife und Witterung, mit grundsätzlichen Erörterungen über die Erfassung der Wetterfaktoren. -- Anzeiger für Schädlingskunde 8, 1-10.
- STÄDLER, E. & SCHÖNI, R. (1991). High sensitivity to sodium in the sugar chemoreceptor of the cherry fruit fly after emergence. -- Physiological Entomology 16, 117-129.
- STAMENKOVIC, S., MILENKOVIC, S., STAMENKOVIC, T., HAMPSON, C. R., ANDERSON, R. L., PERRY, R. L. & WEBSTER, A. D. (1996a). Population dynamics of *Rhagoletis cerasi* L. (Diptera, Tephritidae) in western Serbia. -- Acta Horticulturae 410, 561-565.
- STAMENKOVIC, S., STAMENKOVIC, T., MILENKOVIC, S. & NICOLIC, M. (1996b). Susceptibility of some sweet cherry cultivars to *Rhagoletis cerasi* L. (Diptera, Tephritidae). -- Acta Horticulturae 410, 555-560.
- STEIDLE, J. L. M. & SCHÖLLER, M. (1997). Olfactory host location and learning in the granary weevil parasitoid *Lariophagus distinguendus* (Hymenoptera : Pteromalidae). -- Journal of Insect Behavior 10, 331-342.
- STELLWAAG, F. (1933). Bekämpfung der Kirschfruchtfliege. -- Anzeiger für Schädlingskunde 9, 61-65.
- STRASSER, H., FORER, A. & SCHINER, F. (1996). Development of media for the selective isolation and maintenance of virulence of *Beauveria brongniartii*. -- Conference Proceedings: 3rd international Workshop Microbial control of soil dwelling pests, 125-130.
- STRASSER, H., VEY, A. & BUTT, T. M. (2000). Are there any risks in using entomopathogenic fungi for pest control, with particular reference to the bioactive metabolites of *Metarhizium*, *Tolypocladium* and *Beauveria* species? -- Biocontrol Science and Technology 10, 717-735.
- TAMAI, M. A., ALVES, S. B., LOPES, R. B., FAION, M. & PADULLA, L. F. L. (2002). Toxicidade de produtos fitossanitários para *Beauveria bassiana* (Bals.) Vuill. -- Arquivos do Instituto Biológico 69, 89-96.
- THIEM, H. (1932). Heckenkirschen und Sauerdorn als Wirtspflanzen der Kirschfruchtfliege (*Rhagoletis cerasi* L.). -- Nachrichtenblatt für den Deutschen Pflanzenschutzdienst 12, 41-43.

- (1934). Beiträge zur Epidemiologie und Bekämpfung der Kirschfruchtfliege (*Rhagoletis cerasi* L.). -
- Arbeiten über Physiologische und Angewandte Entomologie Berlin Dahlem 1, 7-79.
- (1935). Untersuchungen zur Biologie der Kirschfruchtfliege (*Rhagoletis cerasi* L.) und ihrer
Wirtspflanzen. -- Arbeiten über Physiologische und Angewandte Entomologie Berlin Dahlem
2, 24-49.
- (1939). Über die Bedeutung der wilden Wirtspflanzen der Kirschfruchtfliege (*Rhagoletis cerasi* L.)
für die Verbreitung und Bekämpfung des Schädling. -- Arbeiten über Physiologische und
Angewandte Entomologie Berlin Dahlem 6, 350-359.
- (1940). Über die Bedeutung der wilden Wirtspflanzen der Kirschfruchtfliege (*Rhagoletis cerasi* L.)
für die Verbreitung und Bekämpfung des Schädling. -- Arbeiten über Physiologische und
Angewandte Entomologie Berlin Dahlem 7, 67-79.
- (1954). Wie ernte ich madenfreie Kirschen. -- Internal Report: Flugblatt K 13, 2. Auflage,
Biologische Bundesanstalt Braunschweig.
- THOMAS, D. B. (2003). Nontarget insects captured in Fruit Fly (Diptera: Tephritidae) surveillance traps.
-- Journal of Economic Entomology 96, 1732-1737.
- THOMAS, D. B., HOLLER, T. C., HEATH, R. R., SALINAS, E. J. & MOSES, A. L. (2001). Trap-lure
combinations for surveillance of *Anastrepha* Fruit Flies (Diptera: Tephritidae). -- Florida
Entomologist 84, 344-351.
- TOLEDO, J. (1999). Toxicity of *Bacillus thuringiensis* beta-endotoxin to three species of fruit flies
(Diptera: Tephritidae). -- Journal of Economic Entomology 92, 1052-1056.
- TOLEDO, J., CAMPOS, S. E., FLORES, S., LIEDO, P., BARRERA, J. F., VILLASEÑOR, A. & MONTOYA, P.
(2007). Horizontal transmission of *Beauveria bassiana* in *Anastrepha ludens* (Diptera:
Tephritidae) under laboratory and field cage conditions. -- Journal of Economic Entomology
100, 291-297.
- TOLEDO, J., IBARRA, J. E., LIEDO, P., GOMEZ, A., RASGADO, M. A. & WILLIAMS, T. (2005). Infection of
Anastrepha ludens (Diptera: Tephritidae) larvae by *Heterorhabditis bacteriophora* (Rhabditida:
Heterorhabditidae) under laboratory and field conditions. -- Biocontrol Science and
Technology 15, 627-634.
- TOLEDO, J., ROJAS, R. & IBARRA, J. E. (2006). Efficiency of *Heterorhabditis bacteriophora* (Nematoda:
Heterorhabditidae) on *Anastrepha serpentina* (Diptera: Tephritidae) larvae under laboratory
conditions. -- Florida Entomologist 89, 524-526.
- TROTTIER, R., RIVARD, I. & NEILSON, W. T. A. (1974). Bait traps for monitoring Apple Maggot activity and
their use for timing control sprays. -- Journal of Economic Entomology 68, 211-213.
- ULEVICIUS, V., PECIULYTE, D., LUGAUSKAS, A. & ANDRIEJAUSKIENE, J. (2004). Field study on changes in
viability of airborne fungal propagules exposed to UV radiation. -- Environmental Toxicology
19, 437-441.
- VÄNNINEN, I., TYNI-JUSLIN, J. & HOKKANEN, H. (2000). Persistence of augmented *Metarrhizium
anisopliae* and *Beauveria bassiana* in Finnish agricultural soils. -- BioControl 45, 201-222.
- VERGUIN, J. (1927). La mouche des cerises (*Rhagoletis cerasi*) - Etat actuel de la question. -- Annales
des Epiphyties 13, 31-44.
- (1928). La mouche de cerises, *Rhagoletis cerasi* L.: Sa biologie, les moyens de la combattre. --
Revue de zoologie agricole et appliquee 27, 17.
- VITA, G., ROSSI, R. & CARPITA, A. (1982). Valutazione in campo dell'efficacia di una trappola chemio-
cromo-tropica per la cattura della mosca delle ciliege, *Rhagoletis cerasi*. -- Redia 65, 319-327.
- VOGEL, W. (1950). Untersuchungen über parasitische Hymenopteren der Kirschenfliege. -- Mitteilung
der Schweizerischen entomologischen Gesellschaft 13, 195-199.
- (1953). Die Bekämpfung der Kirschenfliege im Jahr 1953. -- Schweizerische Zeitschrift für Obst
und Weinbau 62, 87-91.
- WALSTAD, J. D., ANDERSON, R. F. & STAMBAUGH, W. J. (1970). Effects of environmental conditions on
two species of Muscardine fungi (*Beauveria bassiana* and *Metarrhizium anisopliae*). -- Journal
of Invertebrate pathology 16, 221-226.
- WHARTON, R. A. (1989). Classical biological control of fruit-infesting Tephritidae. -- In: Fruit flies their
biology, natural enemies and control. (A. S. Robinson & G. Hooper, eds). Elsevier,
Amsterdam, p. 303-313.
- WHARTON, R. A. & GILSTRAP, F. E. (1983). Key to and status of Opiine Braconid (Hymenoptera)
Parasitoids used in biological control of *Ceratitidis* and *Dacus* s.l. (Diptera: Tephritidae). --
Annals of the entomological Society of America 76, 721-742.
- WHITE, I. M. & ELSON-HARRIS, M. M. (1992). Fruit flies of economic significance: their identification and
binomics. -- CAB International, Oxon, p. 601.

- WIESMANN, R. (1933a). Ein Parasit der Kirschfliege (*Rhagoletis cerasi* L.). -- Mitteilung der Schweizerischen entomologischen Gesellschaft 15, 553-557.
- (1933b). Untersuchungen über die Lebensgeschichte und Bekämpfung der Kirschenfliege *Rhagoletis cerasi* Linné - I. Mitteilung. -- Landwirtschaftliches Jahrbuch der Schweiz, 711-760.
- (1934a). Die Kirschfliege und ihre Bekämpfung. -- Schweizerische Zeitschrift für Obst und Weinbau 43, 545-550.
- (1934b). Untersuchungen über die Lebensgeschichte und Bekämpfung der Kirschenfliege *Rhagoletis cerasi* Linné - II. Mitteilung. -- Landwirtschaftliches Jahrbuch der Schweiz, 281-338.
- (1935a). Die Fauna des Grasbodens unter den Kirschenbäumen. -- Schweizerische Zeitschrift für Obst- und Weinbau 44, 244-246.
- (1935b). Ergebnisse dreijähriger Untersuchungen über die Biologie und Bekämpfung der Kirschfliege *Rhagoletis cerasi* L. in der Schweiz. -- Anzeiger für Schädlingskunde 11, 97-103.
- (1936). Untersuchungen über die Lebensgeschichte und Bekämpfung der Kirschenfliege *Rhagoletis cerasi* Linné - III. Mitteilung Untersuchungen und Versuche aus dem Jahre 1934. -- Landwirtschaftliches Jahrbuch der Schweiz, 811-858.
- (1937a). Das Wirtspflanzenproblem der Kirschenfliege *Rhagoletis cerasi* L. -- Landwirtschaftliches Jahrbuch der Schweiz 51, 1031-1044.
- (1937b). Die Orientierung der Kirschfliege, *Rhagoletis cerasi* L., bei der Eiablage. -- Landwirtschaftliches Jahrbuch der Schweiz, 1080-1109.
- (1938). Befällt die Kirschfliege ausser der Kirsche auch andere Wirte und welche Bedeutung haben diese Wirte. -- Schweizerische Zeitschrift für Obst und Weinbau 47, 348-352.
- (1943). Neue Untersuchungen über die Bekämpfung der Kirschenfliege, *Rhagoletis cerasi* L. -- Schweizerische Zeitschrift für Obst- und Weinbau 52, 232-252.
- (1944). Untersuchungen über das Anködern der Kirschfliege *Rhagoletis cerasi* L. -- Landwirtschaftliches Jahrbuch der Schweiz, 803-840.
- (1950). Untersuchungen über die Diapause der Puppe der Kirschenfliege *Rhagoletis cerasi* L. (Dipt. Trypetid.). -- Mitteilung der Schweizerischen entomologischen Gesellschaft 23, 207-225.
- WRAIGHT, S. P., CARRUTHERS, R. I., JARONSKI, S. T., BRADLEY, C. A., GARZA, C. J. & GALANI-WRAIGHT, S. (2000). Evaluation of the entomopathogenic fungi *Beauveria bassiana* and *Paecilomyces fumosoroseus* for microbial control of the Silverleaf Whitefly, *Bemisia argentifolii*. -- Biological Control 17, 203-217.
- WRAIGHT, S. P. & RAMOS, M. E. (2002). Application parameters affecting field efficacy of *Beauveria bassiana* foliar treatments against Colorado Potato Beetle *Leptinotarsa decemlineata*. -- Biological Control 23, 164-178.
- YEE, W. L. & LACEY, A. (2002). Stage-specific mortality of *Rhagoletis indifferens* (Diptera: Tephritidae) exposed to three species of *Steinernema* nematodes. -- Biological Control 27, 349-356.
- YEE, W. L. & LACEY, L. A. (2005). Mortality of different life stages of *Rhagoletis indifferens* (Diptera: Tephritidae) exposed to the entomopathogenic fungus *Metarhizium anisopliae*. -- Journal of Entomological Science 40, 167-177.
- ZIMMERMANN, G. (1986). The *Galleria* bait method for detection of entomopathogenic fungi in soil. -- Journal of Applied Entomology 102, 213-215.
- ZWÖLFER, H. (1983). Life systems and strategies of resource exploitation in tephritids. -- In: Fruit flies of economic importance (R. Cavalloro, ed). Balkema, Rotterdam, p. 16-30.

11. Curriculum vitae

Name	Claudia Daniel
Date of birth	22 July 1976
Place of birth	Radebeul (near Dresden, Germany)
Marital status	Single
Nationality	German
June 1995	Final examinations at school (grade average of 2.1)
October 1995	Admission to the Dresden University of Applied Sciences (Hochschule für Technik und Wirtschaft Dresden), Subject: Horticulture
14 April – 18 May 1997	Internship at the Dresden-Pillnitz branch (Gene Bank Fruit) of the Institute of Plant Genetics and Crop Plant Research
19 May – 29 August 1997	Internship at the Obstfarm Pietsch & Winkler (integrated production of apples and sour cherries), Dresden
02 November – 18 December 1998	Collaboration on a study at the Saxon Institute for Agriculture (Sächsische Landesanstalt für Landwirtschaft), Dresden
22 March – 13 August 1999	Internship and diploma thesis at the Saxon Institute for Agriculture; Topic: “The effects of artificial weed strips in orchards on the diversity and abundance of arthropod fauna”
September 1999	Final examinations and end of studies (grade average 1.4), major: fruit growing and vegetable growing
01 October 99 – 31 March 00	Employed at a market garden (Gärtnerei Kampfelder Hof), Hannover (organic production of herbs and vegetables)
01 May – 31 October 2000	Internship at the Research Institute of Organic Agriculture (Forschungsinstitut für biologischen Landbau, FiBL, Frick, Switzerland), internship thesis: “The side effects of lime sulphur on predatory mites”
01 April – 30 September 2001	Internship at the Research Institute of Organic Agriculture, internship thesis: “The effects of different soil cultivation systems on epigeic arthropods in an organic cherry orchard”
08 October 01 – 31 January 02	Internship at the European Biological Control Laboratory (EBCL) / United States Department of Agriculture (USDA), Montpellier, France. Project: laboratory rearing of <i>Bactrocera oleae</i>
From March 2002	Project manager for entomology and biocontrol at the Research Institute of Organic Agriculture (FiBL)

Annex I – Location of orchards

All field experiments were conducted in commercial, organically managed orchards. All orchards were located in the region of Basel, northwestern Switzerland, which is a region of intensive sweet cherry production with many old standard trees and a high infestation pressure.

- Annex I – Figure 1: Overview: Location of all experimental orchards in northwestern Switzerland.
- Annex I – Figure 2: Overview: Location of all experimental orchards in Sissach.
- Annex I – Figure 3: Aesch orchard.
- Annex I – Figure 4: Eptingen orchard.
- Annex I – Figure 5: Frick orchard.
- Annex I – Figure 6: Möhlin 1 orchard.
- Annex I – Figure 7: Möhlin 2 orchard and experimental design of soil netting experiment.
- Annex I – Figure 8: Sissach 1 orchard.
- Annex I – Figure 9: Sissach 2 orchard.
- Annex I – Figure 10: Sissach 3 orchard.
- Annex I – Figure 11: Sissach 4 orchard.
- Annex I – Figure 12: Sissach 5 orchard.

Annex I – Figure 1: Overview: Location of all experimental orchards in northwestern Switzerland.

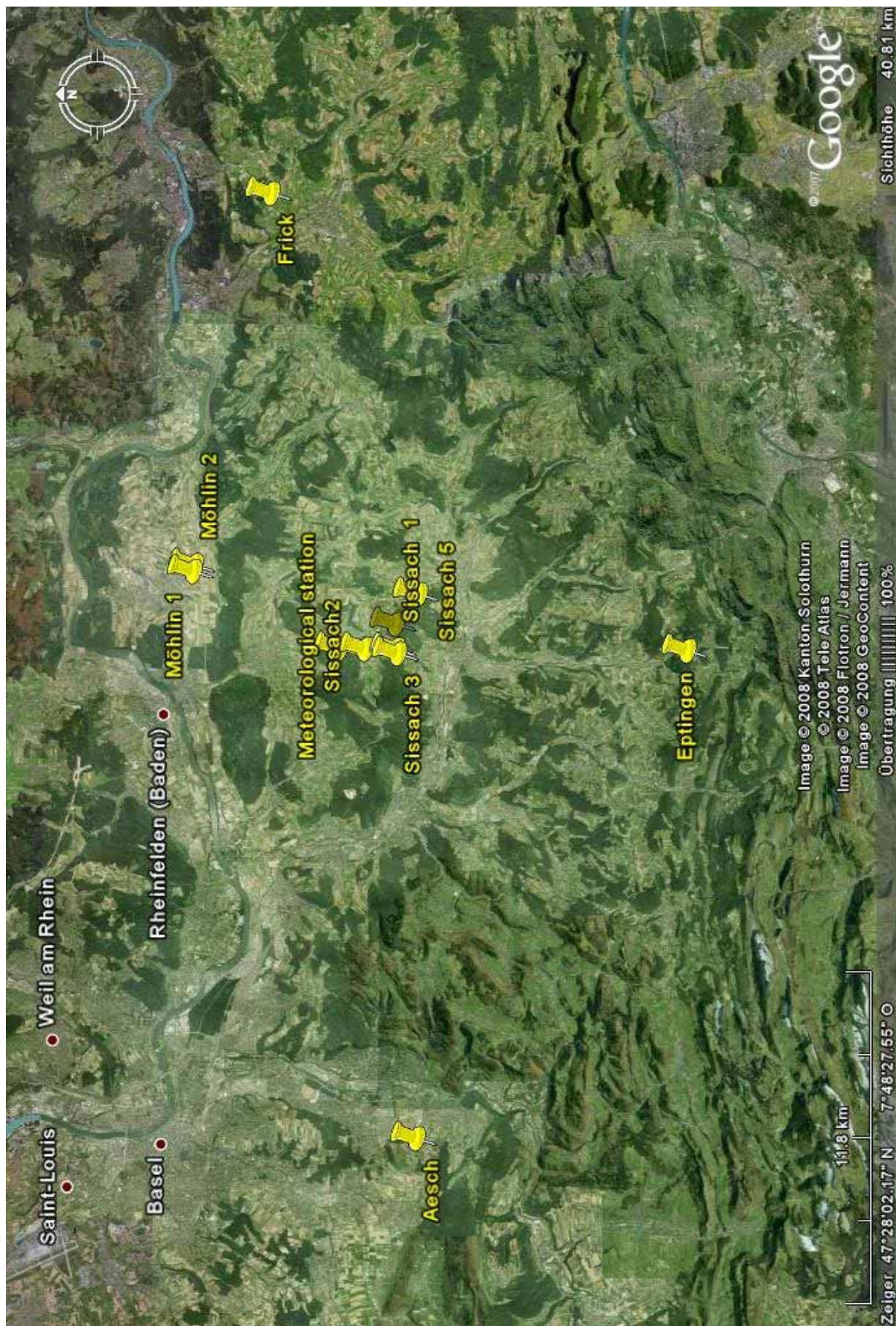

Annex I – Figure 2: Overview: Location of all experimental orchards in Sissach.

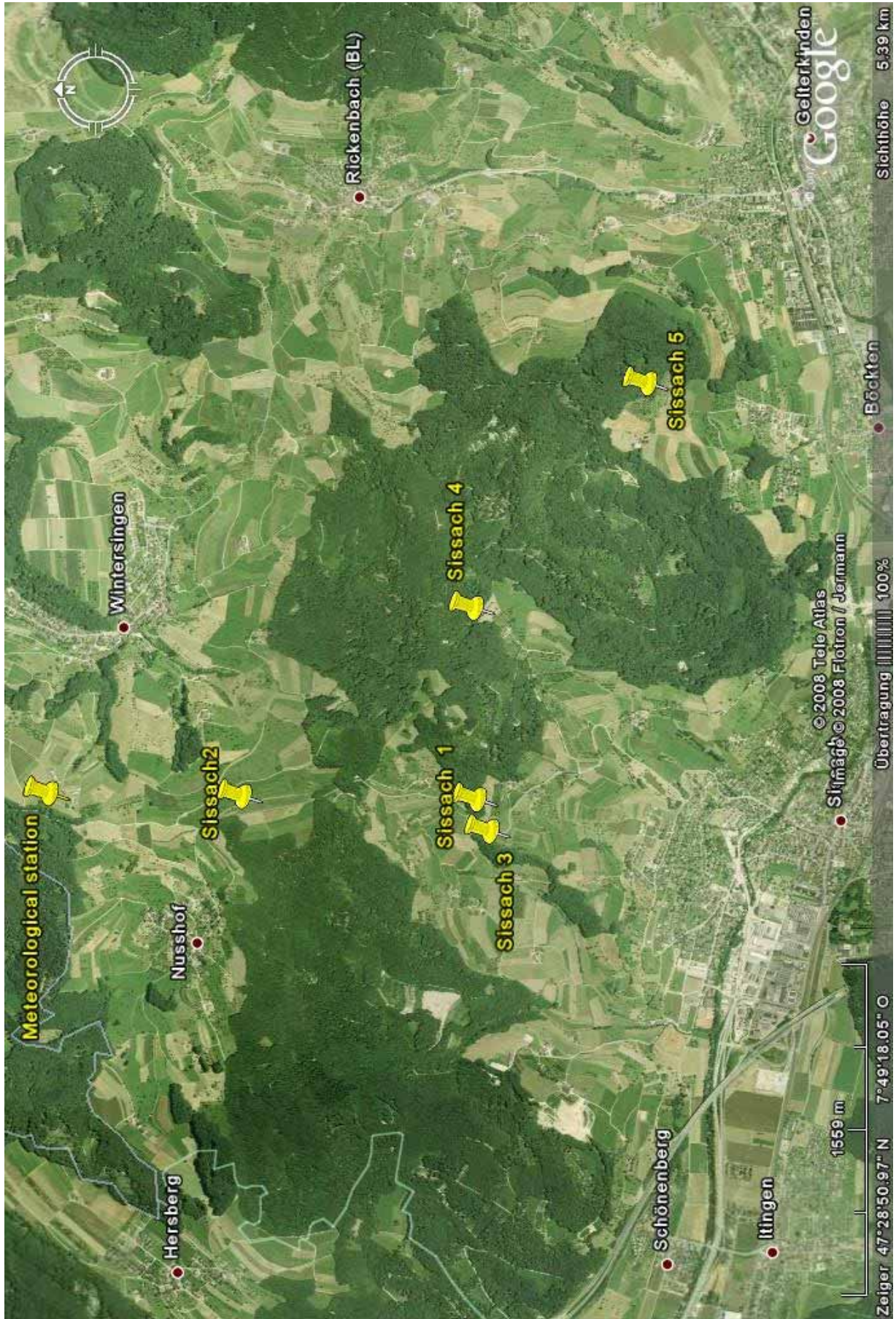

Annex I – Figure 3: Aesch orchard.

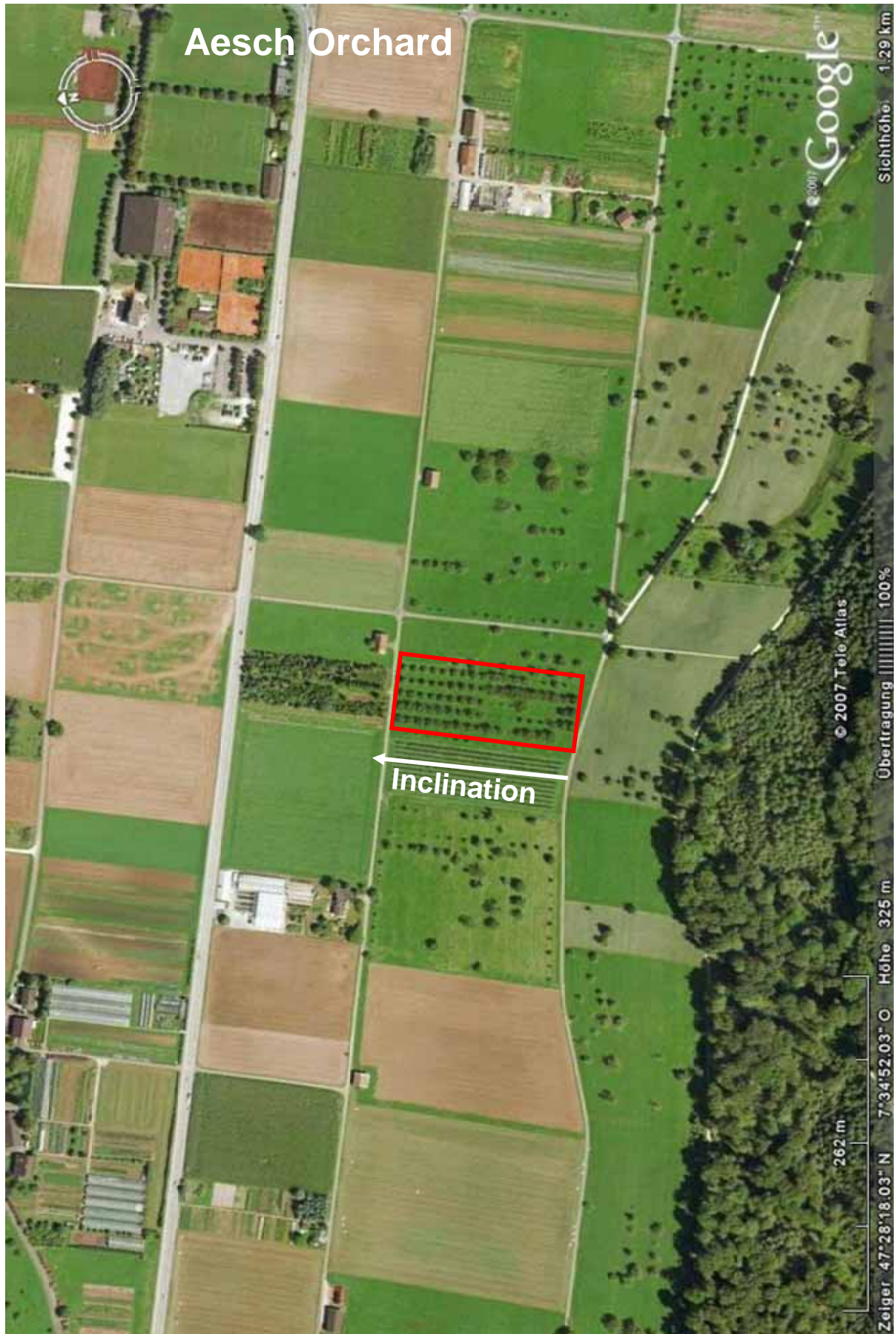

Annex I – Figure 4: Eptingen orchard.

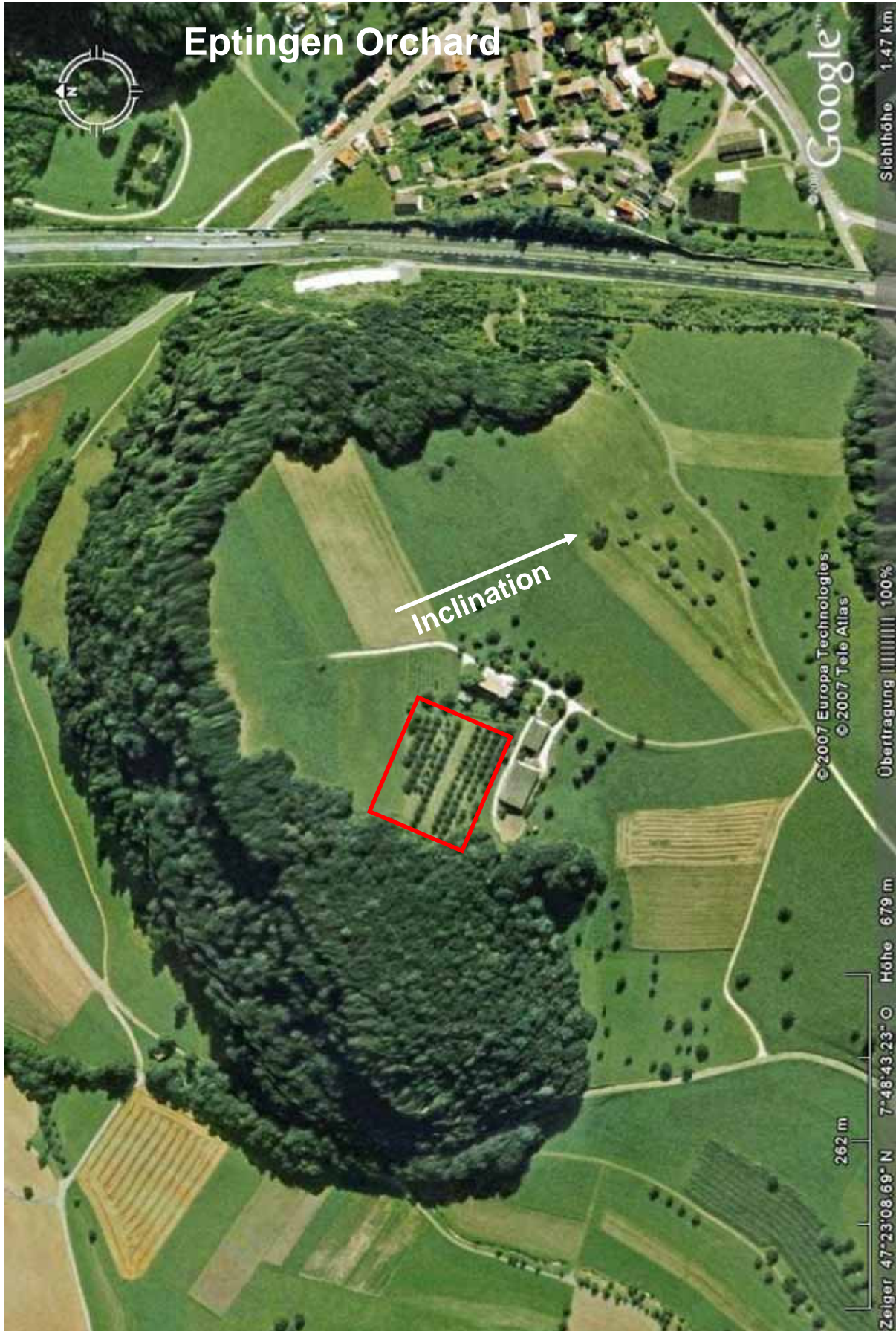

Annex I – Figure 5: Frick orchard.

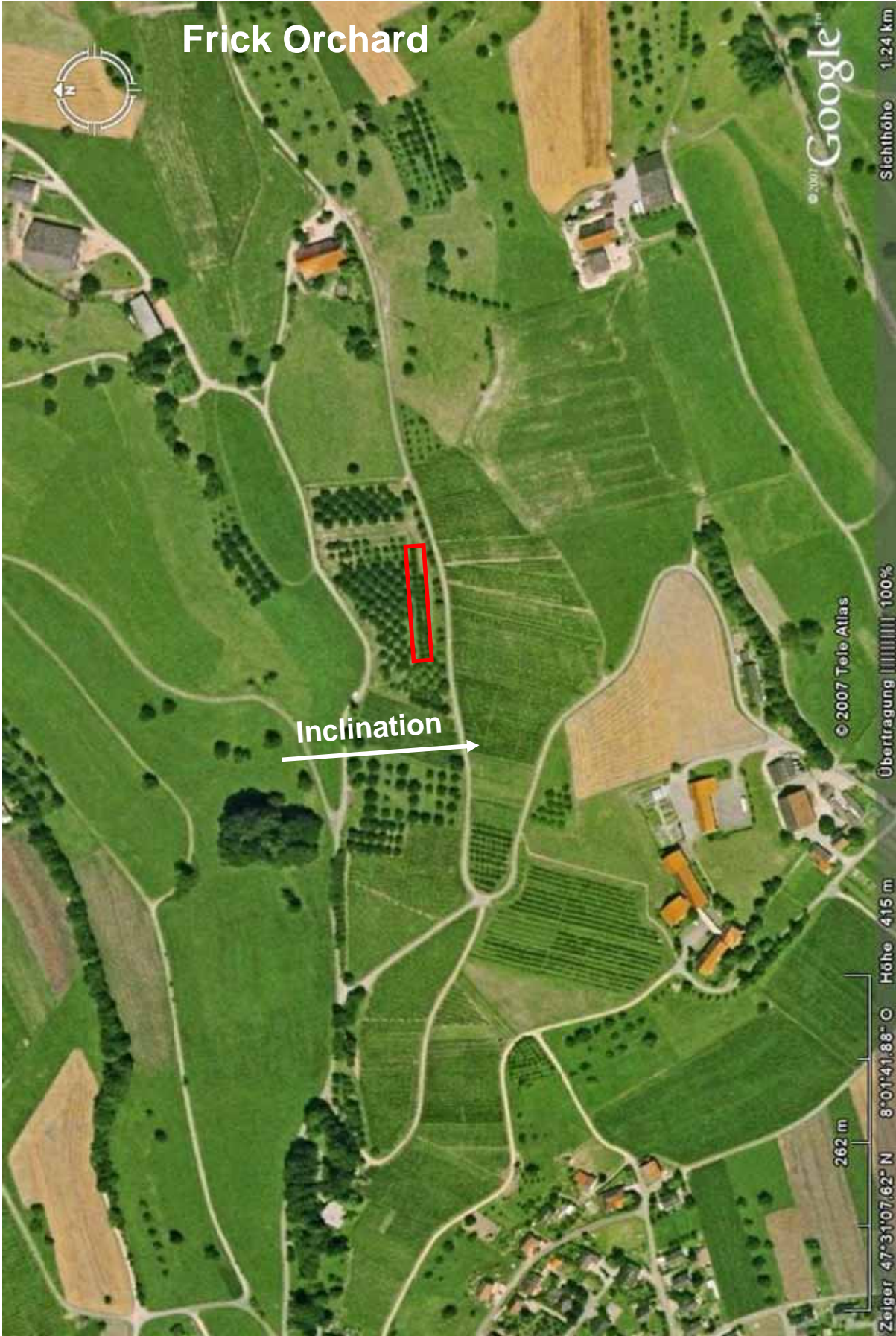

Annex I – Figure 6: Möhlin 1 orchard.

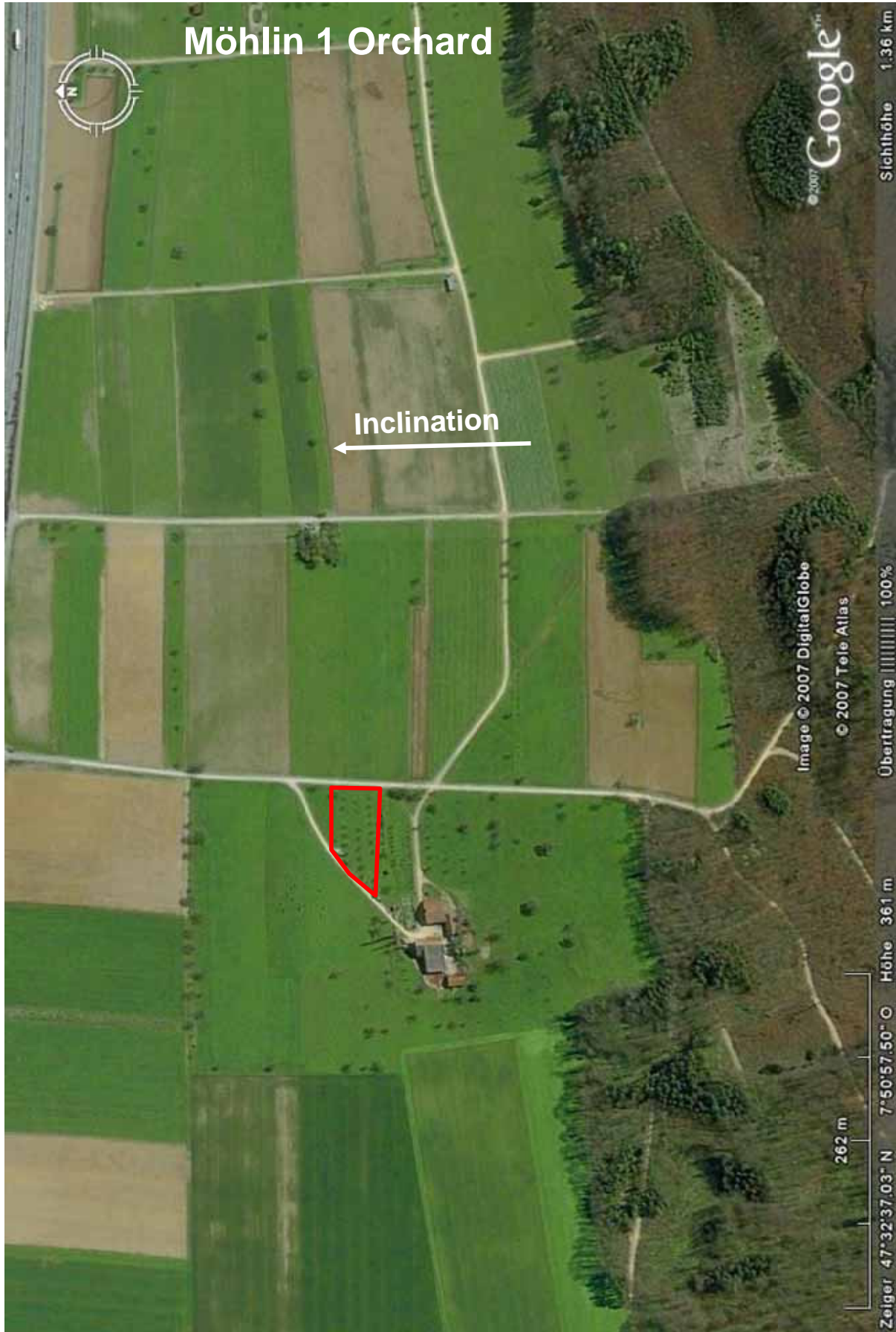

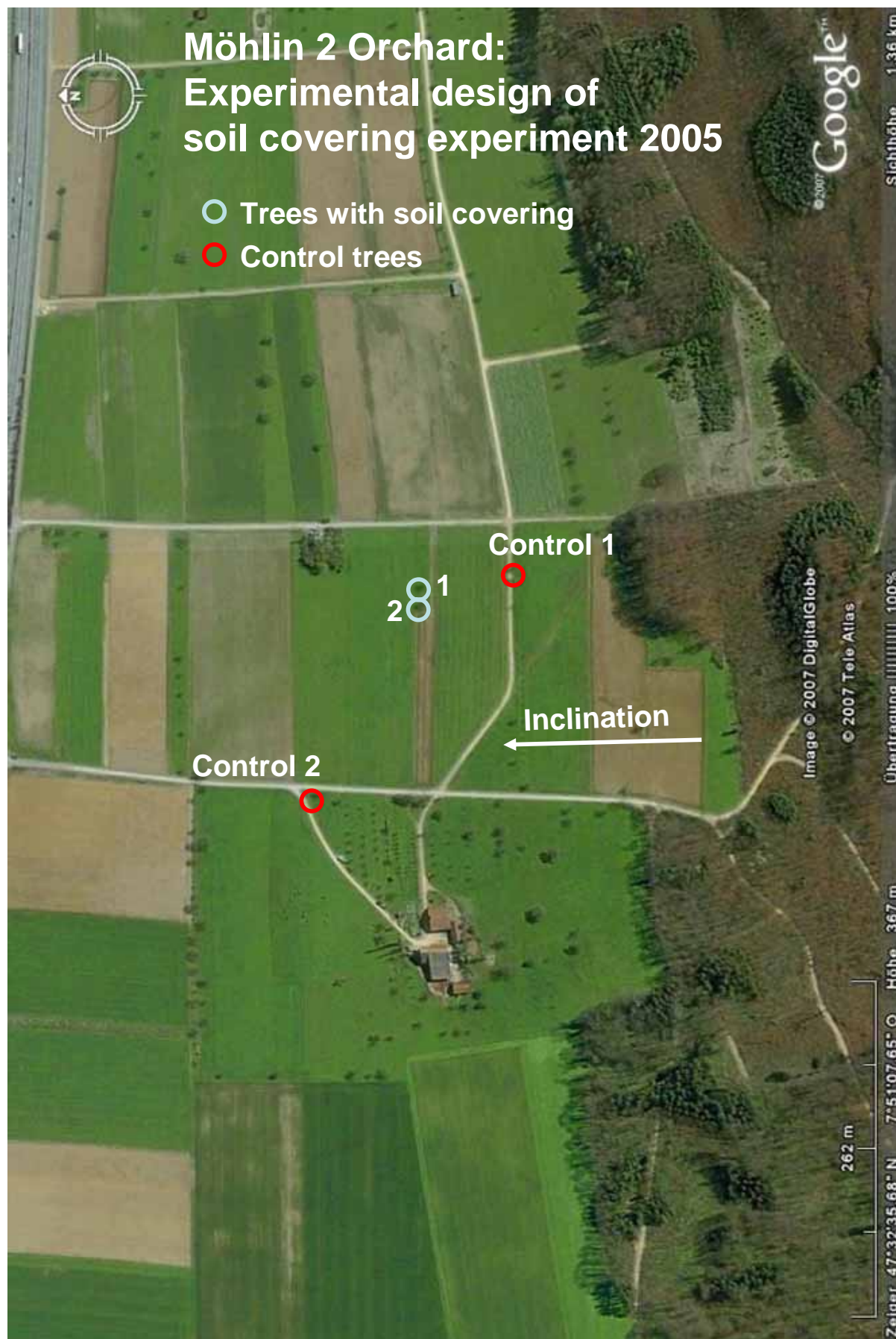

Annex I – Figure 8: Sissach 1 orchard.

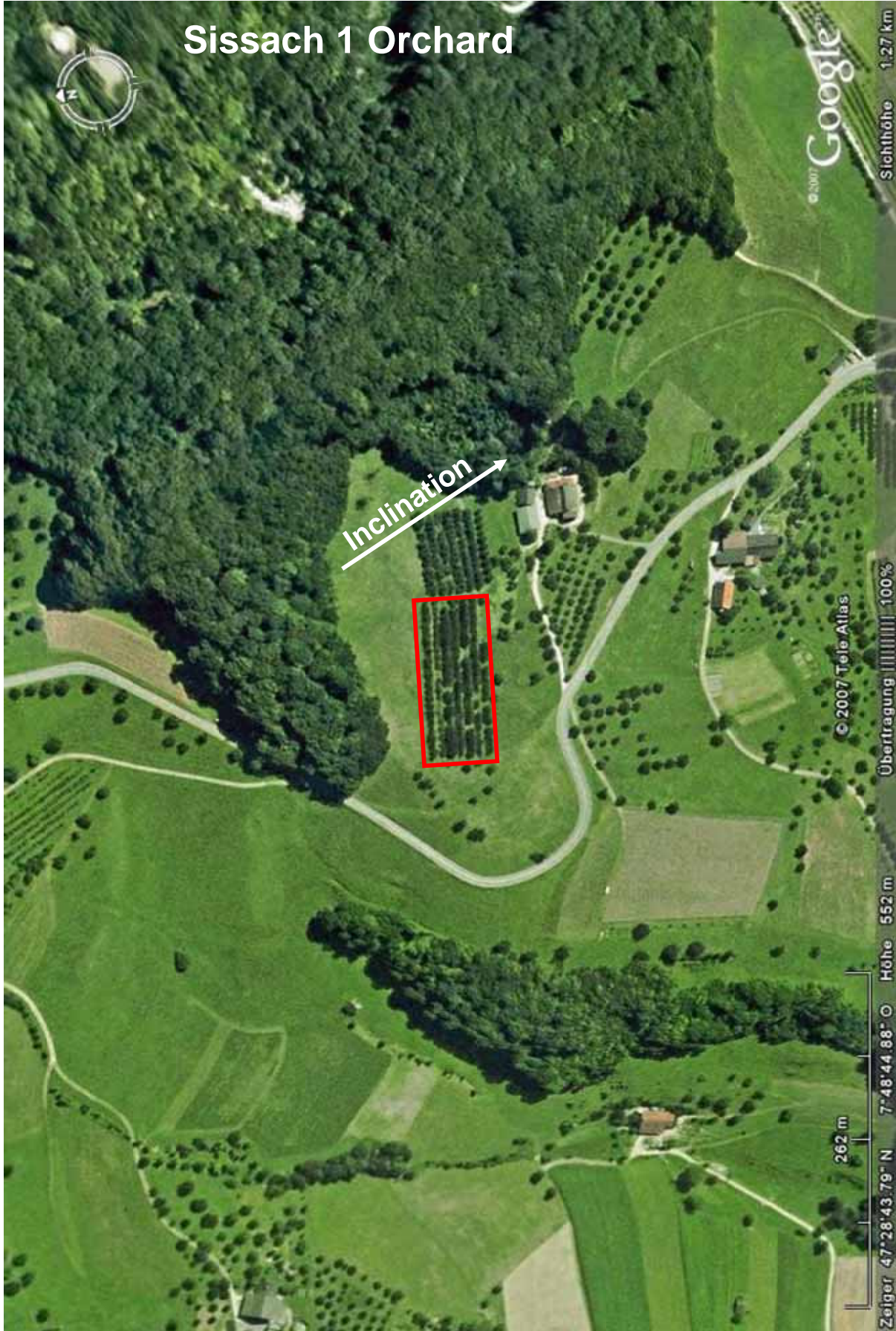

Annex I – Figure 9: Sissach 2 orchard.



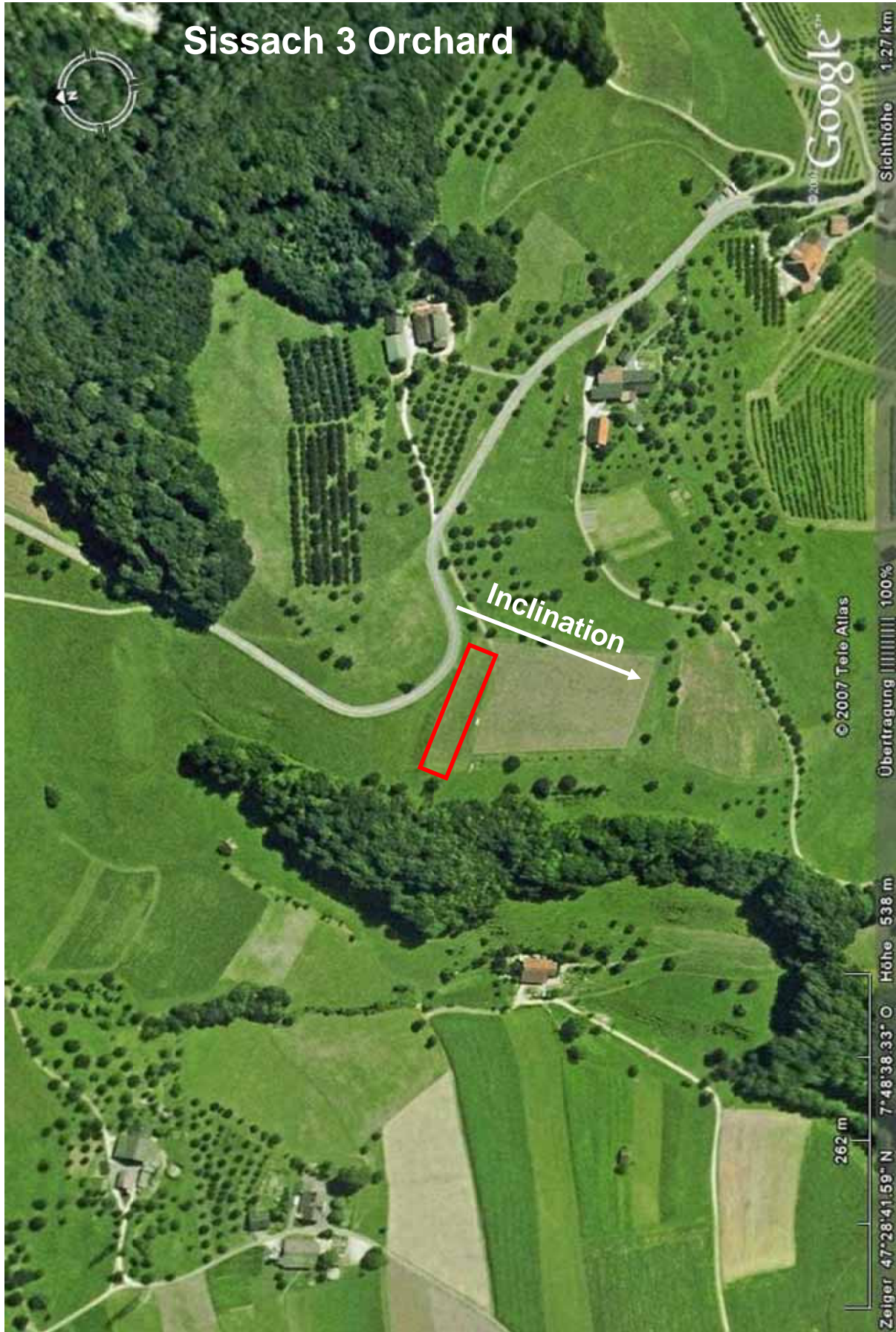



Annex I – Figure 12: Sissach 5 orchard.



Annex II – Experimental designs

- Annex II – Figure 1: Soil covering experiment 2005, Sissach 1 orchard.
- Annex II – Figure 2: Soil covering experiment 2006, Möhlin 1 orchard.
- Annex II – Figure 3: Soil treatment 2006, Aesch orchard.
- Annex II – Figure 4: Soil treatment 2006, Eptingen orchard.
- Annex II – Figure 5: Soil treatment 2007, Frick.
- Annex II – Figure 6: Traps and baits 2004, Aesch orchard.
- Annex II – Figure 7: Traps and baits 2005, Aesch orchard.
- Annex II – Figure 8: Traps and baits 2006, Aesch orchard.
- Annex II – Figure 9: Traps and baits 2005, Möhlin 1, Sissach 5 and Frick orchards.
- Annex II – Figure 10: Traps and baits 2006, Eptingen orchard.
- Annex II – Figure 11: Field trials Naturalis-L 2006 and 2007, Sissach 2 orchard.
- Annex II – Figure 12: Field trial Naturalis-L 2007, Sissach 3 orchard.
- Annex II – Figure 13: Field trial Naturalis-L & PreFeRal®WG 2006, Sissach 4 orchard.
- Annex II – Figure 14: Field trial Naturalis-L 2007, Eptingen orchard.
- Annex II – Figure 15: Field trial Telmion (Rape oil) 2006, Eptingen orchard.

Experimental design – Soil covering experiment 2005, Sissach 1 orchard

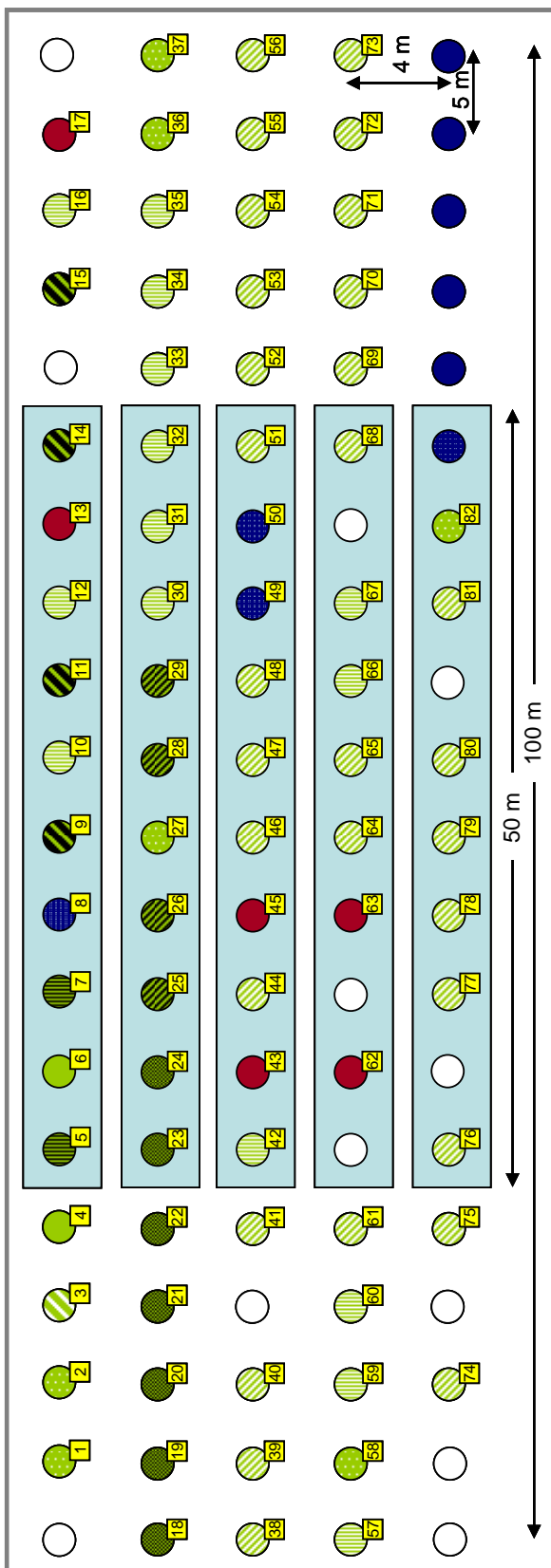

Cherry varieties

- Basler Adler
- Magda
- Kordia
- Schauenburger
- Heidegger
- Beta
- Zweitruhe
- Dolseppler
- Regina
- Missing tree
- Plum tree
- Tree removed shortly before experiment

Yellow sticky trap

netting



Experimental plots (mean per plot was calculated from the following trees before performing the statistical analysis)

Treatment	Control	Netting	Netting
Replicate		Border area	Centre
Row 1	1, 2, 3, 4, 15, 16	5, 6, 14	7, 9, 10, 11, 12
Row 2	18, 19, 20, 21, 22, 33, 34, 35, 36, 37	23, 24, 31, 32	25, 26, 27, 28, 29, 30
Row 3	38, 39, 40, 41, 52, 53, 54, 55, 56	42, 51	44, 46, 47, 48,
Row 4	57, 58, 59, 60, 61, 69, 70, 71, 72, 73	68	64, 65, 66, 67
Row 5	74, 75	76, 82	77, 78, 79, 80, 81

Experimental design – Soil covering experiment 2006, Möhlin 1 orchard

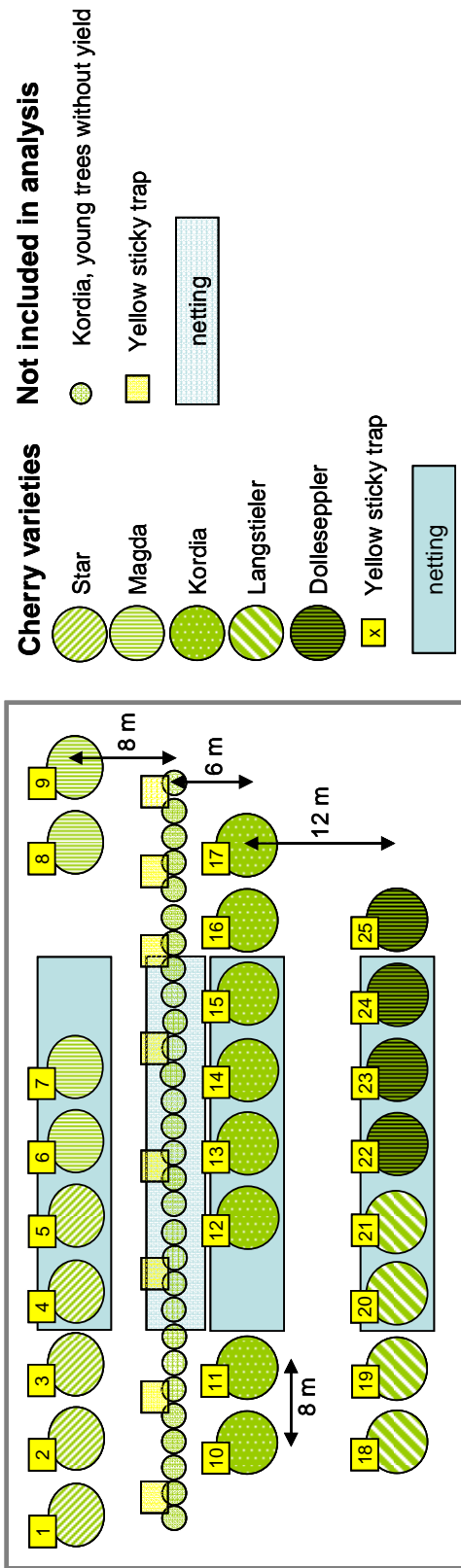

Experimental plots (mean per plot was calculated from the following trees before performing the statistical analysis)

Replicate	Treatment	Control	Netting Border area	Netting Centre
Variety Star		1, 2, 3	4	5
Variety Magda		8, 9	-	6, 7
Variety Kordia 1		10, 11	-	12, 13
Variety Kordia 2		16, 17	15	14
Variety Langstieler		18, 19	20	21
Variety Dolleseppler		25	24	22, 23

Average Number of flies per trap on variety Kordia in the preceding year 2005

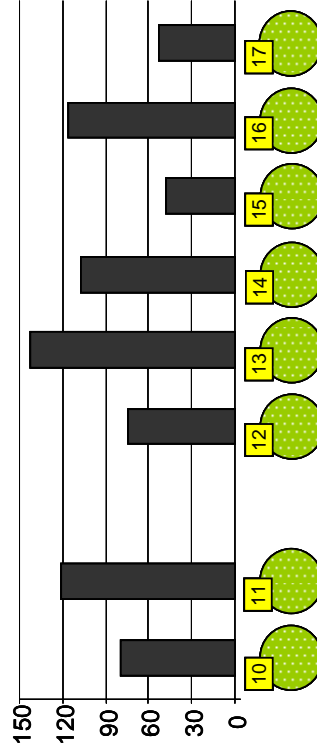

Experimental design – Soil treatment 2006, Aesch orchard

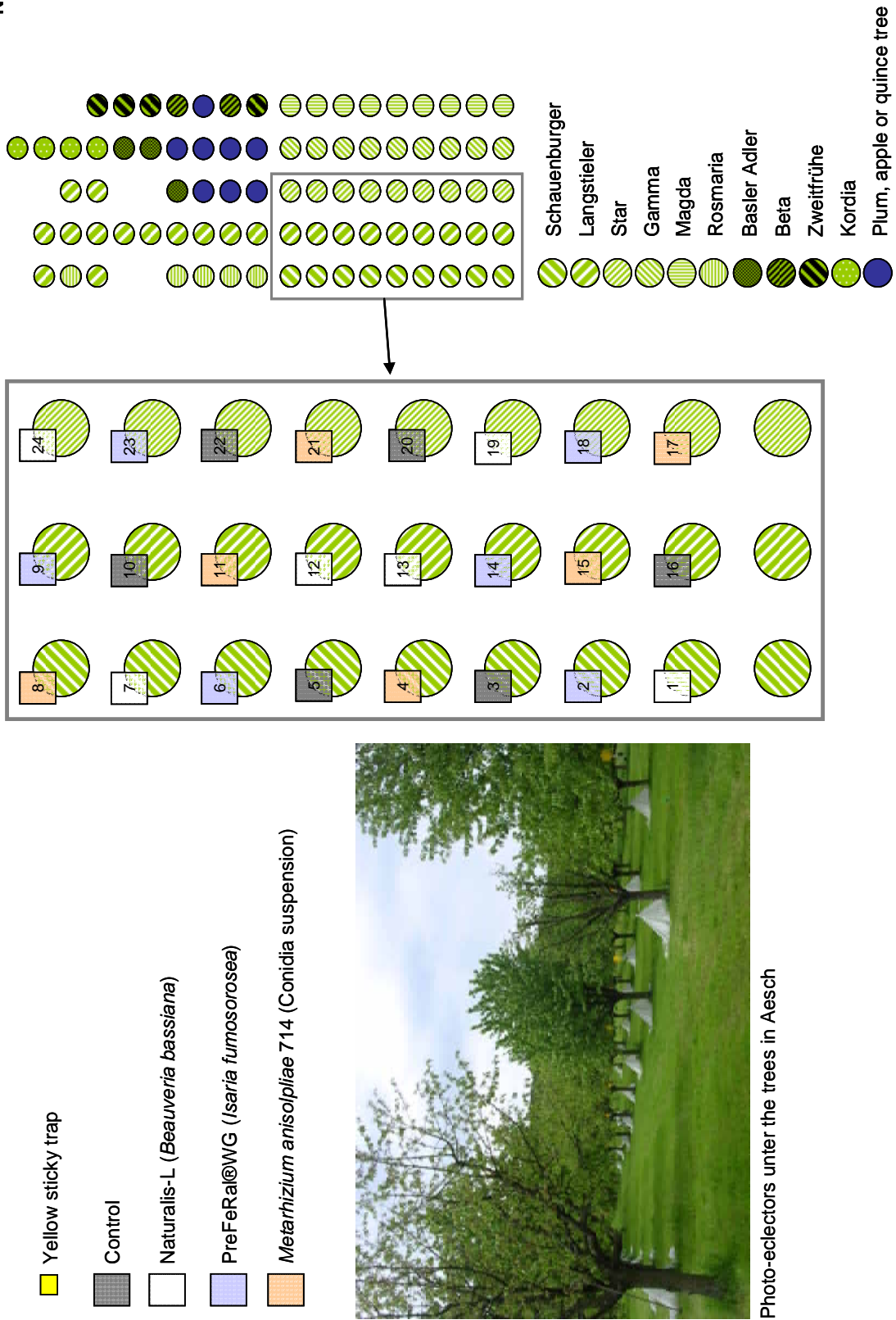

Experimental design – Soil treatment 2006, Eptingen orchard

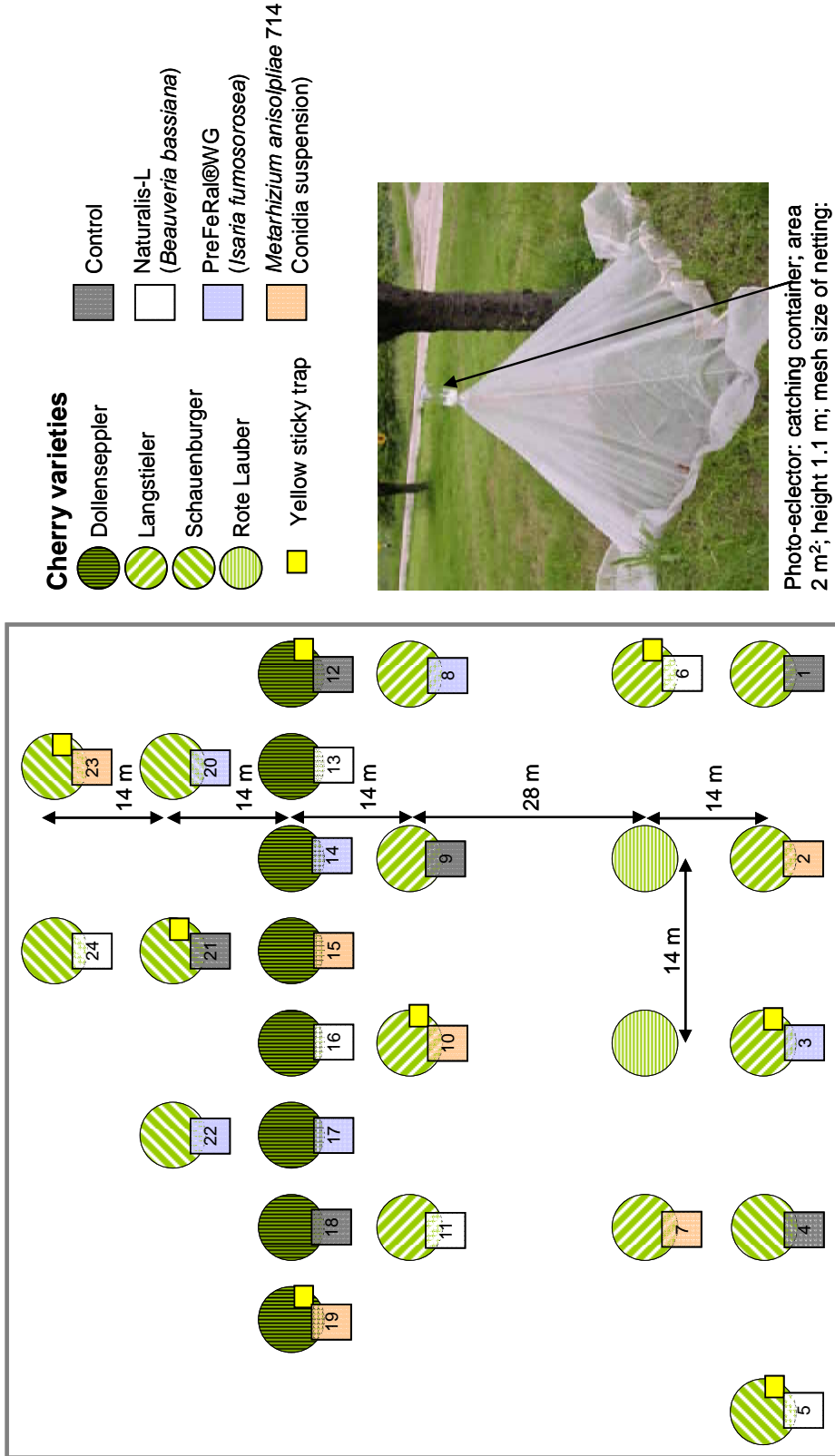

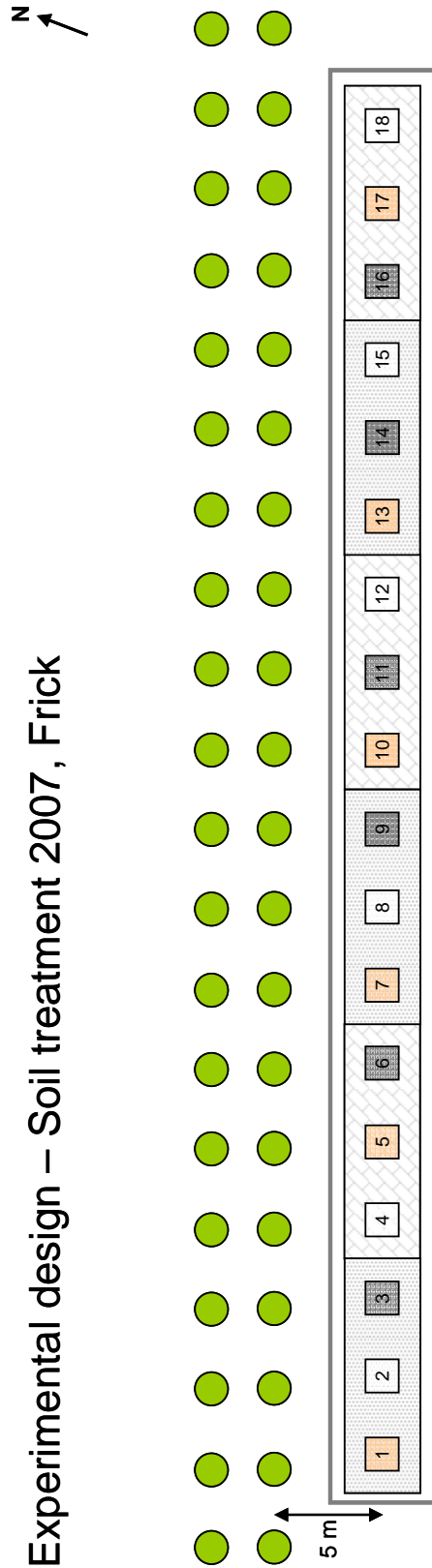

Experiments were conducted in a meadow close to a cherry orchard
 Pupae of *R. cerasi* collected in 2006 were exposed to fungus treated soil

- 1 Plot size 1 m x 1 m;
- Distance between plots: 1.3 m
- Cherry tree

Treatments

- Control
- Beauveria bassiana* ATCC74040
- Metarhizium anisopliae* 714

Origin of Pupae (collection site in 2006)

- Sissach 4 and 5 orchards
- Eptingen orchard

Experimental design – Traps and baits 2004, Aesch orchard



Yellow sticky trap

Yield

No yield

Very low yield

Low yield

Normal yield

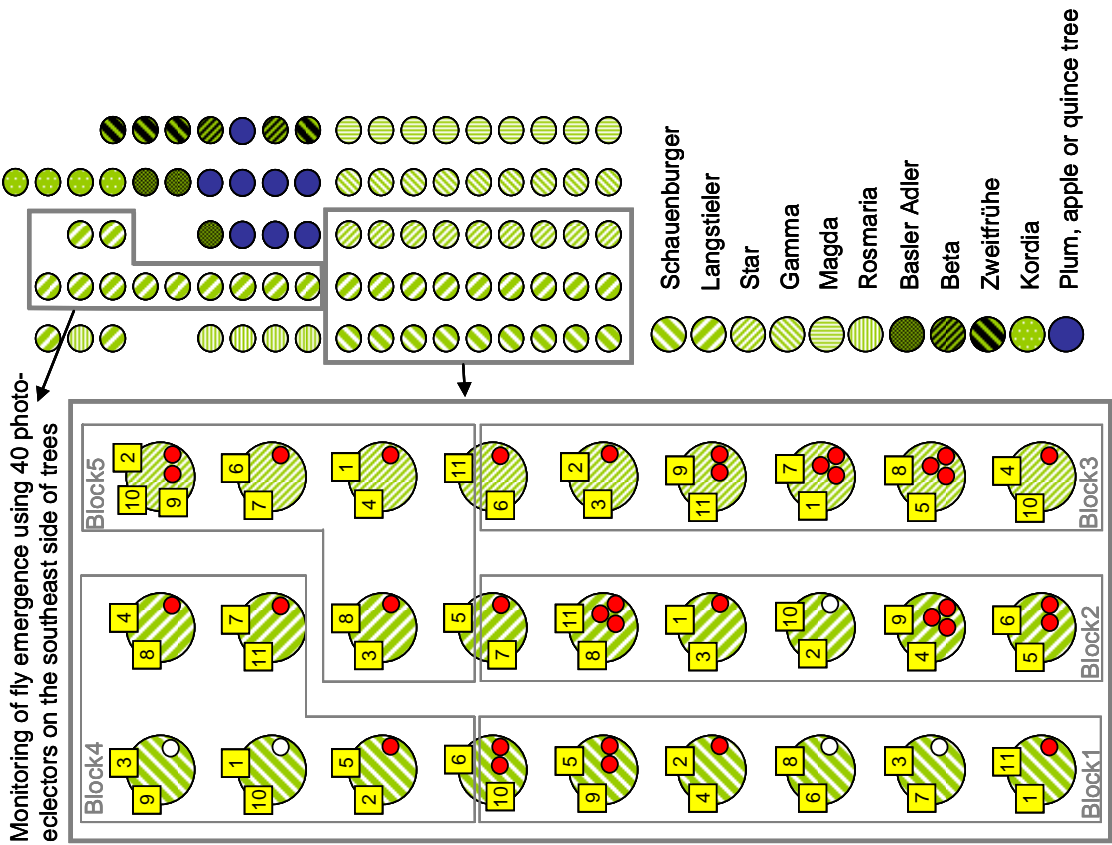

Name	Nb	Trap	Bait
Rebell / Water	4	Rebell@amarillo with bottle	Water
Rebell / Fruct	1	Rebell@amarillo with bottle	Fruct@ Bait for <i>R. cerasi</i>
Rebell X/ Fruct	3	Rebell@amarillo with bottle designed for <i>Xyleborus dispar</i>	Fruct@ Bait for <i>R. cerasi</i>
Fruct / Water	5	Fruct@ trap	Water
Fruct / Fruct	2	Fruct@ trap	Fruct@ Bait for <i>R. cerasi</i>
Rebell / Fruct olive	9	Rebell@amarillo with bottle	Fruct@ Bait for <i>Bactrocera oleae</i>
Rebell / 5%+50%	10	Rebell@amarillo with bottle	Yeast hydrolysate (5%) + ammonium acetate (50%)
Rebell / 2.5%+10%	7	Rebell@amarillo with bottle	Yeast hydrolysate (2.5%) + ammonium acetate (10%)
Rebell / Lysodin	8	Rebell@amarillo with bottle	Lysodin Algafert (organic liquid fertiliser)
Rebell / Nu Lure	6	Rebell@amarillo with bottle	Nu Lure
Rebell / Agar	11	Rebell@amarillo with bottle	Ammonium acetate, Diaminobutane, Trimethylamine

Experimental design – Traps and baits 2005, Aesch orchard

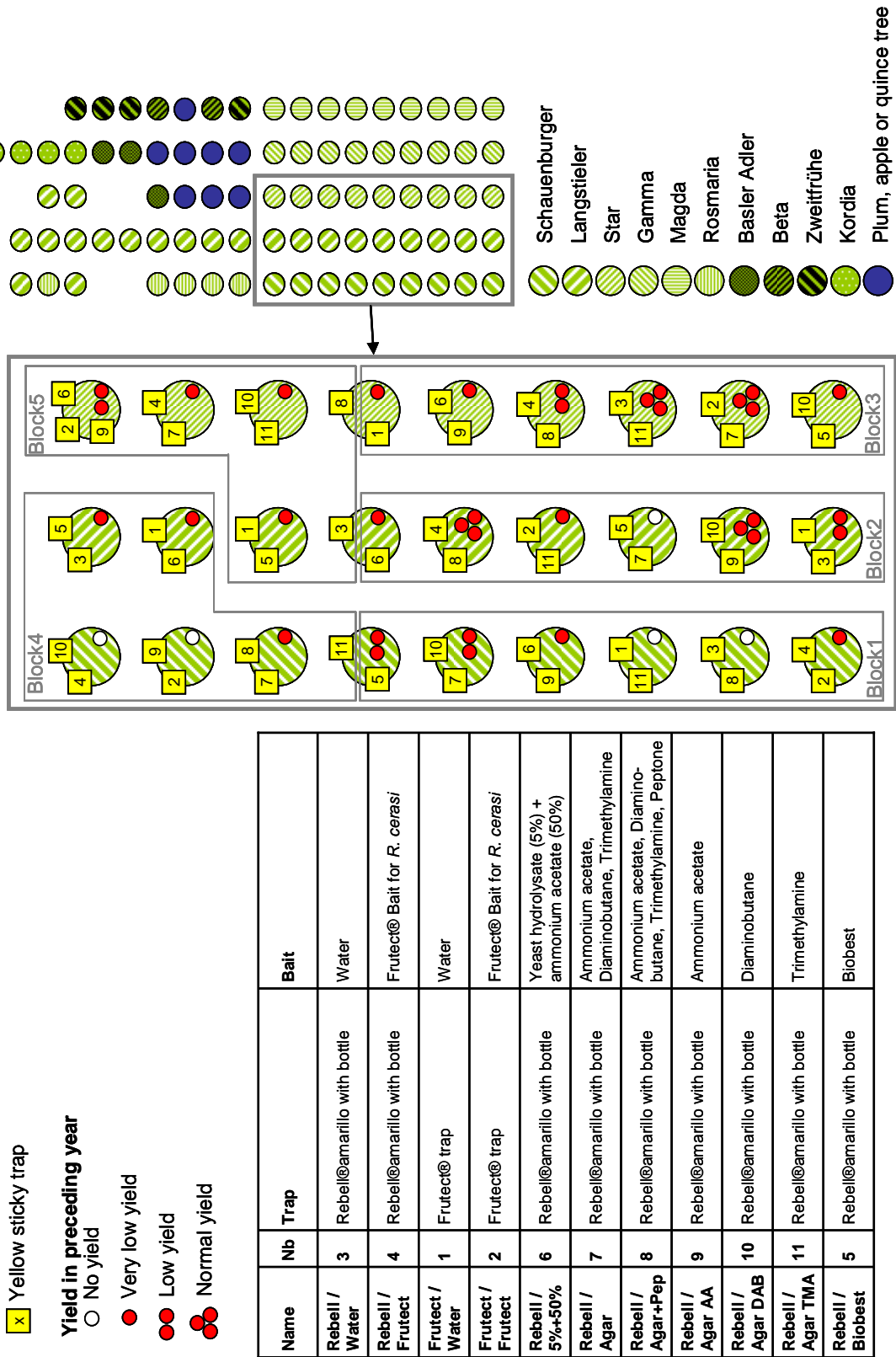

Experimental design – Traps and baits 2006, Aesch orchard

 Yellow sticky trap

Name	Nb	Trap	Bait
Rebell / Water	9	Rebell@amarillo with bottle	Water
Rebell / Fructect	8	Rebell@amarillo with bottle	Fructect® Bait for <i>R. cerasi</i>
Fructect / Water	10	Fructect® trap	Water
Fructect / Fructect	11	Fructect® trap	Fructect® Bait for <i>R. cerasi</i>
Rebell / 5%+50%	3	Rebell@amarillo with bottle	Yeast hydrolysate (5%) + ammonium acetate (50%)
Rebell / Lysodin	2	Rebell@amarillo with bottle	Lysodin Algafert (organic liquid fertiliser)
Rebell / Agar	4	Rebell@amarillo with bottle	Ammonium acetate, Diaminobutane, Trimethylamine
Rebell / Susbin TMD	5	Rebell@amarillo with bottle	Trimedlure
Rebell / Susbin TMA	6	Rebell@amarillo with bottle	TMA-card
Rebell / Susbin	7	Rebell@amarillo with bottle	Susbin tablet with Pheromone
Rebell / Stable	1	Rebell@amarillo with bottle	Bait for stable flies

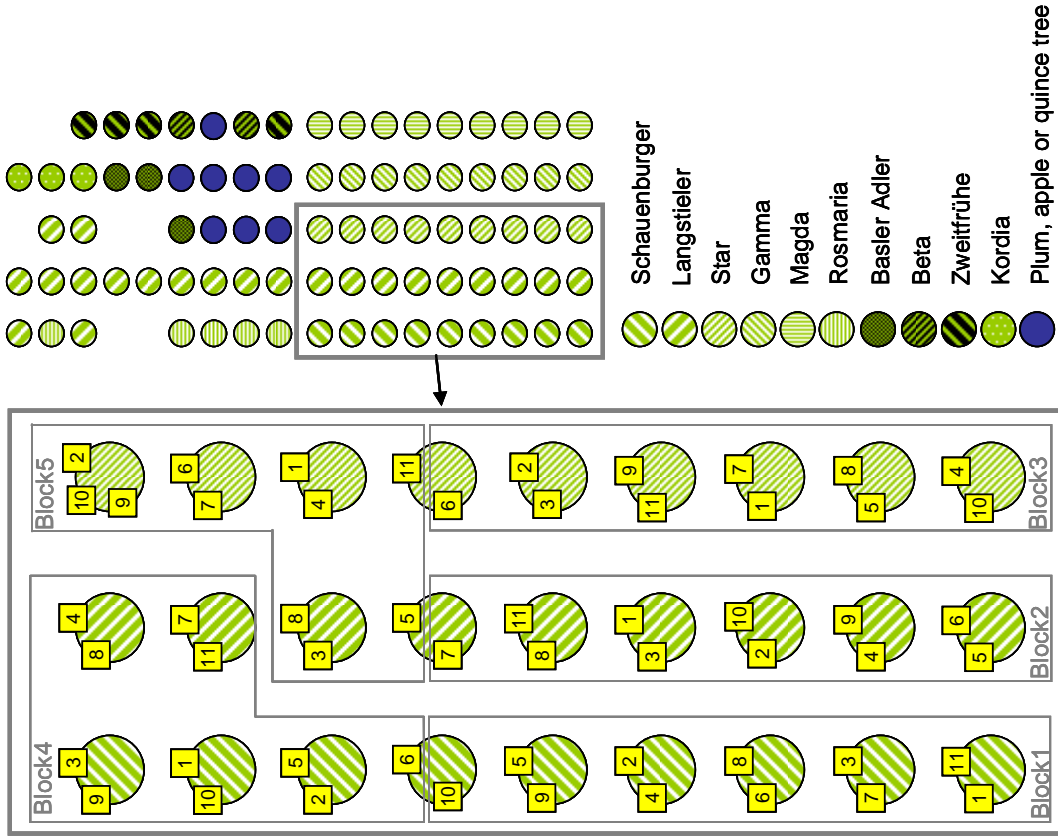

Experimental design – Traps and baits 2005, Möhlin 1 orchard

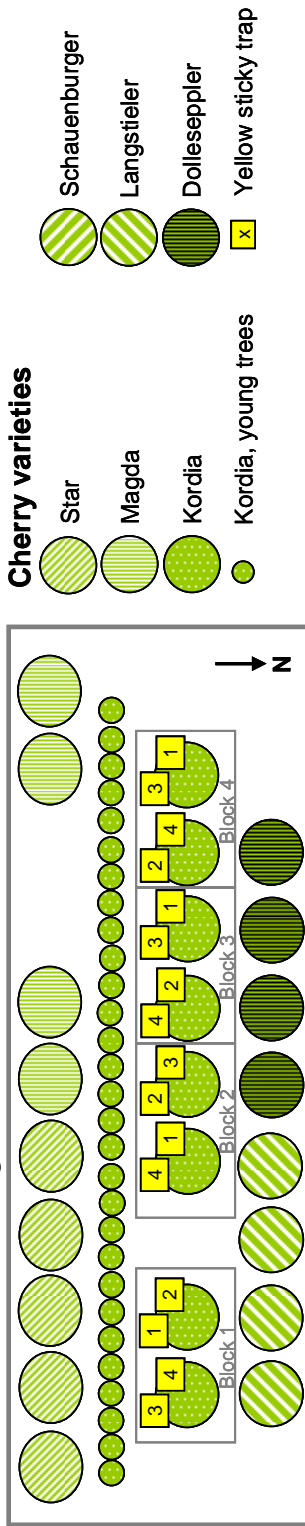

Experimental design – Traps and baits 2005, Sissach 5 orchard

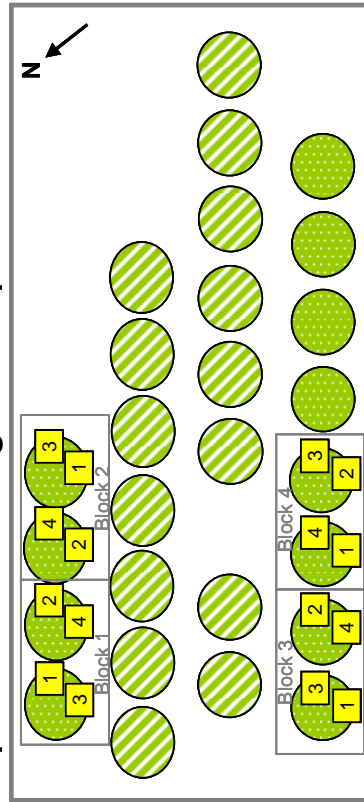

Name	Nb	Trap	Bait
Rebell / Water	1	Rebell@amarillo with bottle	Water
Fructect / Fructect	2	Fructect® trap	Fructect® Bait for <i>R. cerasi</i>
Rebell / Lysodin	4	Rebell@amarillo with bottle	Lysodin Algafert (organic liquid fertiliser)
Rebell / Agar	3	Rebell@amarillo with bottle	Ammonium acetate, Diaminobutane, Trimethylamine

Experimental design – Traps and baits 2005, Frick orchard

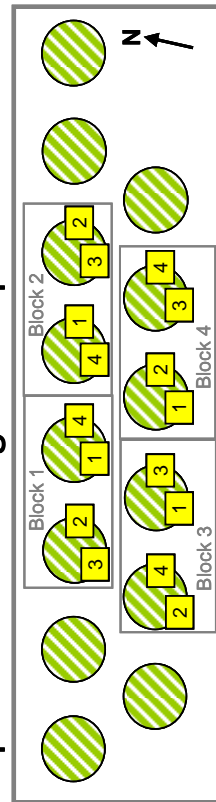

Experimental design – Traps and baits 2006, Eptingen orchard

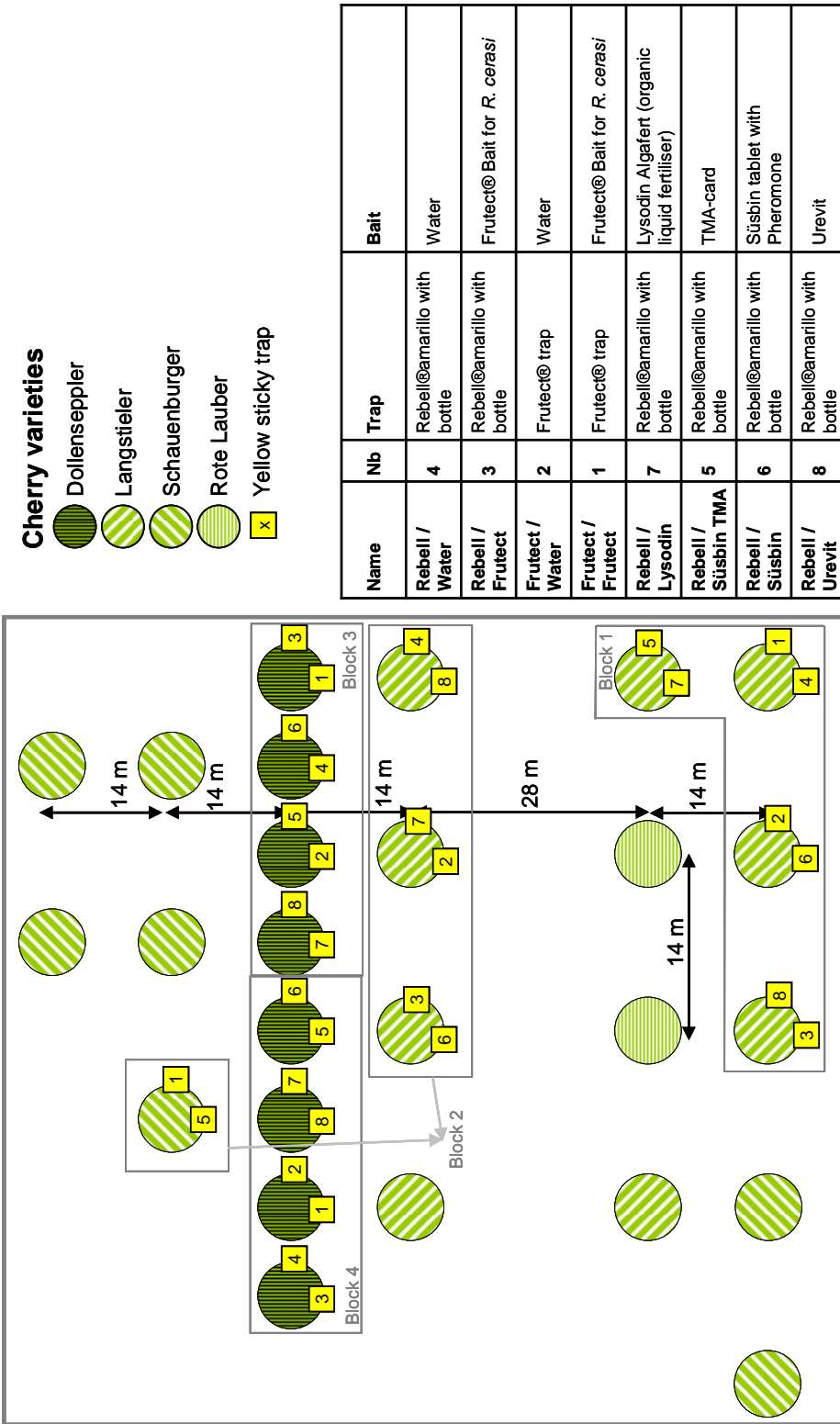

Experimental design – Field trials Naturalis-L 2006 and 2007, Sissach 2 orchard

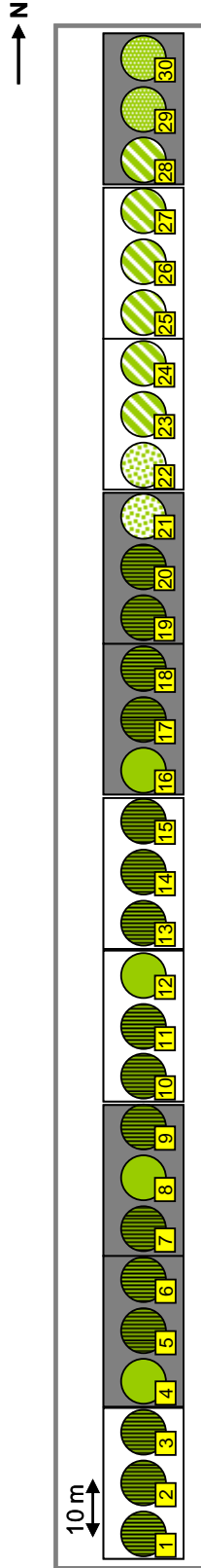

Cherry varieties

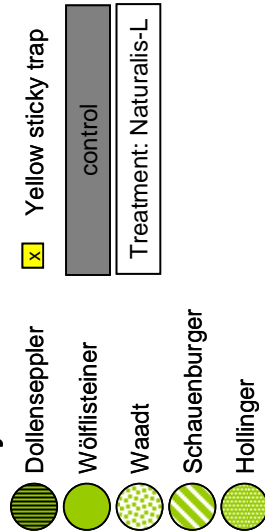

Experimental plots (mean per plot was calculated from the following trees before performing the statistical analysis)

Replicate	Treatment	Naturalis-L
Replicate 1	control	1, 2, 3
Replicate 2	control	4, 5, 6
Replicate 3	control	7, 8, 9
Replicate 4	control	10, 11, 12
Replicate 5	control	13, 14, 15
Replicate 1	Naturalis-L	16, 17, 18
Replicate 2	Naturalis-L	19, 20, (21)
Replicate 3	Naturalis-L	(22), 23, 24
Replicate 4	Naturalis-L	25, 26, 27
Replicate 5	Naturalis-L	28, 29, (30)

In 2006, the following trees were not included in the statistical analysis:

Tree 21 and 22: no yield

Tree 30: very low yield and very high infestation in remaining fruits (64%)

Experimental design – Field trial Naturalis-L 2007, Sissach 3 orchard

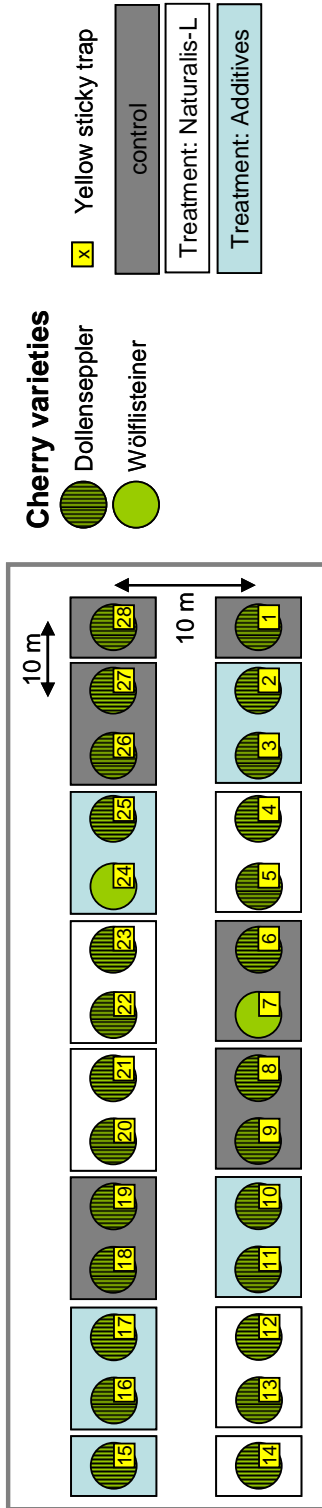

Experimental plots (mean per plot was calculated from the following trees before performing the statistical analysis)

Replicate	Treatment	Naturalis-L	Additives of Naturalis-L
Replicate 1	control	4, 5	2, 3
Replicate 2	control	6, 7	
Replicate 2	Additives	8, 9	10, 11
Replicate 3	Additives	12, 13	
Replicate 3	control	18, 19	16, 17
Replicate 4	control	20, 21	
Replicate 4	Additives	22, 23	24, 25



Experimental design – Field trial Naturalis-L & PreFeRaI®WG 2006, Sissach 4 orchard

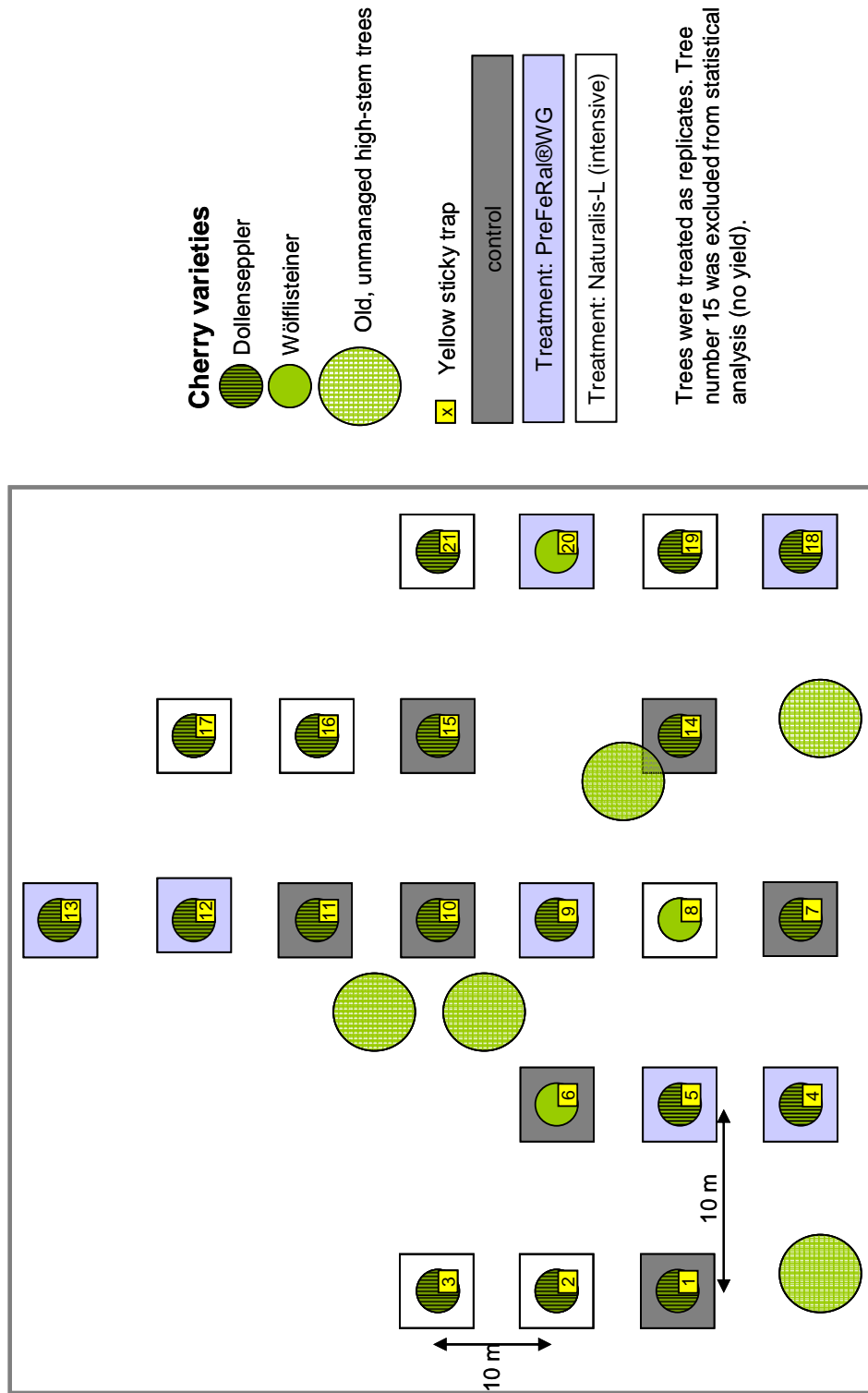

Experimental design – Field trial Naturalis-L 2007, Eptingen orchard

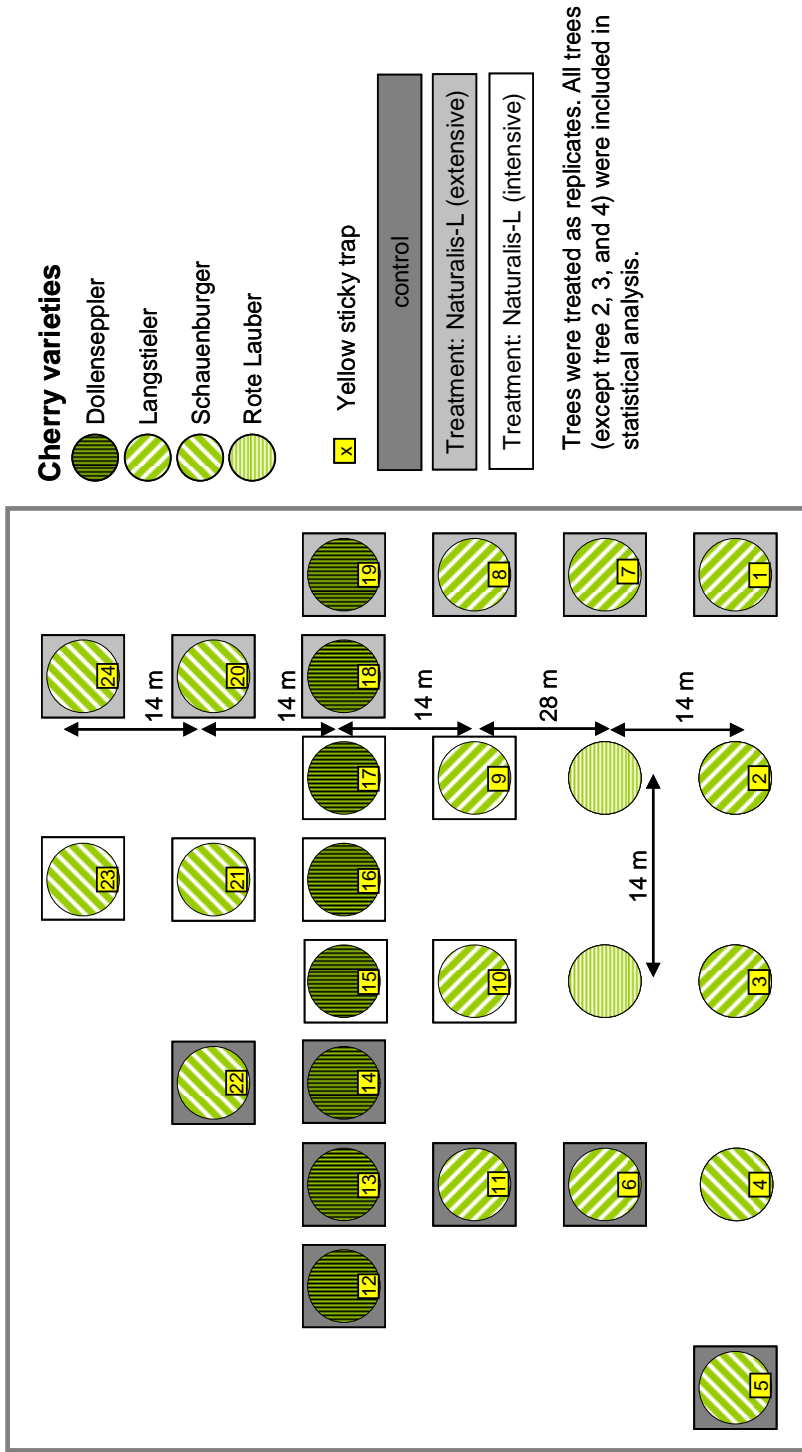

Experimental design – Field trial Telmion (Rape oil) 2006, Eptingen orchard

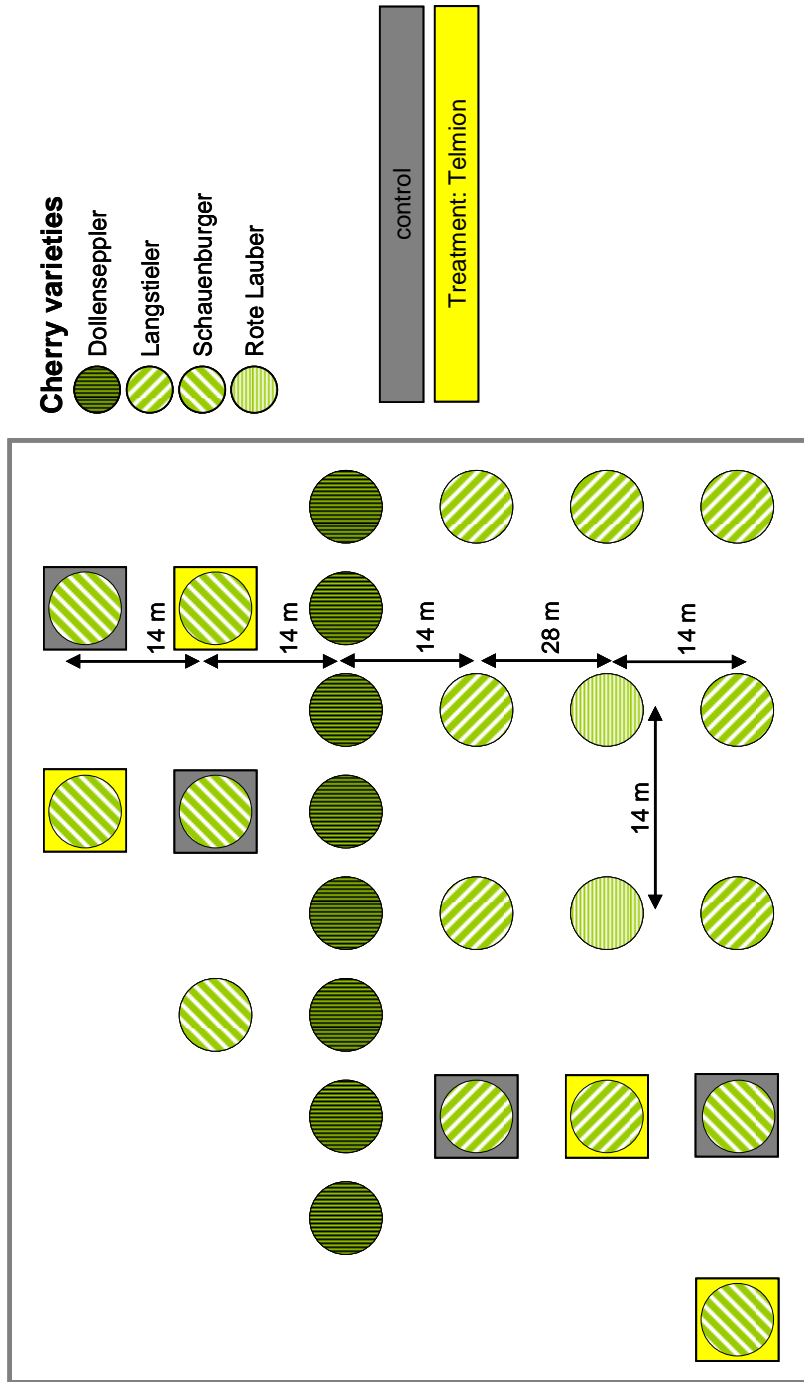

Annex III – Climatic conditions

The climatic conditions were monitored using a Campbell CR10X meteorological station in Wintersingen (BL). Location of the meteorological station is given in Annex I – Figure 1 and 2.

Annex III – Figure 1: Climatic conditions in 2004.

Annex III – Figure 2: Climatic conditions in 2005.

Annex III – Figure 3: Climatic conditions in 2006.

Annex III – Figure 4: Climatic conditions in 2007.

